

# DRIVING A HEAVY VEHICLE

---

## LES PUBLICATIONS DU QUÉBEC

1000, route de l'Église, bureau 500, Québec (Québec) G1V 3V9

### SALES AND DISTRIBUTION

Telephone 418 643-5150 // Toll Free 1 800 463-2100

[publicationsduquebec.gouv.qc.ca](http://publicationsduquebec.gouv.qc.ca)

**Bibliothèque et Archives nationales du Québec  
and Library and Archives Canada  
cataloguing in publication**

Driving a heavy vehicle.

ISSN 1489-9183

ISBN 978-551-26250-2

1. Truck driving. 2. Truck driving – Québec (Province). I. Société de l'assurance automobile du Québec.

TL230.3.C6613

629.28'44

C99-802719-7

# DRIVING A HEAVY VEHICLE

**This edition was published by**  
Les Publications du Québec  
425, rue Jacques-Parizeau, 5<sup>e</sup> étage  
Québec (Québec) G1R 4Z1

**Project leader, art direction,  
production, computer graphics**  
Les Publications du Québec

**Illustrations**  
Jean-Michel Girard

**Graphic design**  
Dièse

**This publication was prepared by**  
the Société de l'assurance  
automobile du Québec.

**Researched and written by**  
Direction de la formation,  
du soutien légal et des politiques  
and the Direction de l'expertise  
et de la sécurité des véhicules

**Collaboration**  
The vice-presidencies at the  
Société de l'assurance automobile  
du Québec, the Ministère des  
Transports, and the Centre  
de formation en transport  
de Charlesbourg

**Project coordination**  
The Direction des communications

**Translation**  
The Direction des communications

Legal deposit – 2018  
Bibliothèque et Archives nationales du Québec

ISBN  
978-2-551-26250-2 (Printed)  
ISBN 978-2-551-26260-1 (PDF)

© Gouvernement du Québec – 2018

All rights reserved for all countries.  
Reproduction by any means and translation  
of any part of this document are prohibited  
without the authorization of Les Publications du Québec.  
Original text in French

# INTRODUCTION

Sharing the road calls for courtesy and mutual respect on the part of all road users. As a professional driver at the wheel of a heavy vehicle, you must be informed of your rights and obligations, but it is equally essential that you be aware of the importance of adopting safe, cooperative and responsible behaviour.

This guide is a summary of the standards and rules of conduct that apply to driving a heavy vehicle. Although primarily intended for those who are in the process of learning to drive this type of vehicle, it also serves as a reference document for all heavy vehicle drivers. The 12 chapters contained herein present the principle obligations of heavy vehicle drivers, certain driving techniques as well as safety standards heavy vehicles are required to meet. This ninth edition also covers the regulatory amendments that have come into force in recent years, in particular as they apply to impaired driving and vehicle circle checks.

Visit the website of the Société de l'assurance automobile du Québec ([saaq.gouv.qc.ca](http://saaq.gouv.qc.ca)) to find out more about road safety and its requirements. For any reference of a legal nature, you can consult the *Highway Safety Code* and its attendant regulations.

# TABLE OF CONTENTS

Introduction .....	5
--------------------	---

## CHAPTER 1

### THE DRIVER'S RESPONSIBILITIES 21

Habits you must develop .....	23
-------------------------------	----

- ▶ Seat belts ..... 23
- ▶ Alcohol and drugs ..... 23
- ▶ Electronic devices and driving ..... 24
- ▶ Headrest adjustment ..... 26
- ▶ At the wheel ..... 26

Rules .....	29
-------------	----

Spring thaw restrictions .....	31
--------------------------------	----

Highway carrier monitoring .....	33
----------------------------------	----

Mandatory stops at inspection stations .....	35
--	----

Obligations .....	36
-------------------	----

In the event of an accident .....	39
-----------------------------------	----

Move-Over Law .....	40
---------------------	----

In the presence of road work .....	40
------------------------------------	----

In the presence of a flagperson .....	41
---------------------------------------	----

Self-evaluation exercises .....	42
---------------------------------	----

## CHAPTER 2

### FACTORS THAT INFLUENCE DRIVING 43

Driver fatigue .....	45
----------------------	----

- ▶ Effects of fatigue on driving ..... 45
- ▶ Learning to recognize the signs ..... 46
- ▶ Three factors determining fatigue ..... 46
- ▶ Aggravating factors ..... 47
- ▶ Recommendations for managing fatigue ..... 50
- ▶ For more information ..... 51

Inattentiveness .....	51
-----------------------	----

<b>Distractions</b> .....	<b>51</b>
<b>Speed</b> .....	<b>52</b>
<b>Alcohol</b> .....	<b>53</b>
<b>Drugs and medications</b> .....	<b>54</b>
<b>Certain features of your vehicle and their impact on your driving</b> .....	<b>57</b>
▶ Vehicle size and weight .....	57
▶ Condition of the tires .....	58
▶ Checking fluids in hot weather .....	59
▶ Getting your vehicle ready for winter .....	59
<b>Driving in difficult conditions</b> .....	<b>60</b>
▶ Driving at night .....	60
▶ Rain or shine .....	62
<b>Self-evaluation exercises</b> .....	<b>64</b>
<b>CHAPTER 3</b>	
<b>KNOW YOUR VEHICLE</b> .....	<b>67</b>
<b>Types of heavy vehicles</b> .....	<b>69</b>
▶ Various configurations .....	69
<b>Dashboard indicators</b> .....	<b>71</b>
<b>Steering wheel</b> .....	<b>72</b>
▶ Hand position .....	72
<b>Accelerator</b> .....	<b>73</b>
<b>Types of transmissions</b> .....	<b>74</b>
▶ Automatic transmission .....	74
▶ Manual transmissions .....	77
<b>The right RPM is important for your engine</b> .....	<b>84</b>
▶ Limiting speed = fuel savings .....	85
▶ Brakes .....	86
▶ Hydraulic brake controls and indicators .....	86
<b>Self-evaluation exercises</b> .....	<b>88</b>

## CHAPTER 4

### PNEUMATIC (AIR) BRAKE SYSTEMS 89

<b>The most popular brake system</b> .....	<b>91</b>
<b>Controls and components</b> .....	<b>92</b>
▶ Driver's cab .....	92
▶ Other parts of the vehicle.....	96
<b>How service brakes work</b> .....	<b>103</b>
▶ Compressed air .....	103
▶ Pressure amplification.....	103
▶ Reaction time .....	105
▶ Braking power.....	107
<b>How the parking brake works</b> .....	<b>109</b>
<b>How the emergency brake works</b> .....	<b>111</b>
<b>Supplemental brake systems</b> .....	<b>112</b>
▶ How they work.....	113
<b>Anti-lock brakes</b> .....	<b>114</b>
<b>Brake inspection</b> .....	<b>115</b>
<b>Brake adjustment</b> .....	<b>115</b>
▶ Automatic self-adjusting brake levers.....	116
▶ Manual brake levers.....	117
<b>Self-evaluation exercises</b> .....	<b>118</b>

## CHAPTER 5

### DRIVING KNOW-HOW AND ROAD SAFETY 119

<b>Keep your eyes open</b> .....	<b>121</b>
▶ Look well ahead .....	121
▶ Check blind spots .....	123
▶ Check rearview mirrors .....	124
▶ Signal your intentions.....	125
<b>Allow yourself enough space</b> .....	<b>126</b>
▶ Space ahead .....	126
▶ Space behind .....	128
▶ Space to the sides.....	129



▶ Space overhead .....	130
<b>Negotiating a curve .....</b>	<b>132</b>
<b>Turning at an intersection .....</b>	<b>134</b>
▶ The basics.....	134
<b>Braking distance .....</b>	<b>139</b>
<b>How to bring your vehicle to a stop .....</b>	<b>139</b>
▶ Factors that influence braking distance .....	140
<b>Backing up .....</b>	<b>142</b>
▶ Things to check when backing up .....	142
▶ How to back up .....	145
<b>Changing lanes .....</b>	<b>147</b>
<b>Passing .....</b>	<b>148</b>
▶ Do not signal others to pass you .....	148
<b>Driving uphill .....</b>	<b>149</b>
<b>Driving downhill .....</b>	<b>150</b>
▶ Check road signs and signals .....	150
▶ Check your brakes before starting down a hill, no matter what kind of brake system you have .....	150
▶ Mandatory check.....	151
▶ Driving down a gentle grade.....	152
▶ Driving down a steep grade .....	152
▶ Using your brakes when driving down a steep grade .....	152
<b>Supplemental brakes .....</b>	<b>154</b>
▶ Using your transmission and engine compression to slow down on a downhill grade .....	154
▶ Automated manual transmission.....	155
▶ Pulling over to the side of the road .....	155
▶ Pulling over on a secondary road .....	156
▶ Pulling over on a highway .....	157
▶ Level crossings .....	158
<b>Self-evaluation exercises .....</b>	<b>160</b>

## CHAPTER 6

## COPING WITH DANGEROUS SITUATIONS 161

<b>What should you do when you get a flat tire?</b>	<b>163</b>
▶ Flat tire: rear tire on a dual-wheeled vehicle.....	163
▶ Flat tire: front tire, or rear tire on a single-wheeled vehicle (wide-tread) .....	164
<b>What is hydroplaning and how should you react?</b>	<b>165</b>
▶ What should you do? .....	165
<b>What causes skidding?</b>	<b>166</b>
▶ Braking abruptly .....	166
▶ Driving up or down a hill.....	166
▶ How to avoid skidding.....	167
<b>How to recover from a skid</b>	<b>168</b>
▶ Maintain steering control .....	169
<b>What causes jackknifing?</b>	<b>170</b>
<b>How to make an emergency stop</b>	<b>171</b>
<b>If your brakes should fail despite all your efforts</b>	<b>172</b>
▶ How to bring your vehicle to a stop.....	173
<b>If your vehicle catches fire</b>	<b>176</b>
▶ What to do in the event of an emergency.....	176
<b>If an animal strays onto the road</b>	<b>177</b>
<b>Self-evaluation exercises</b>	<b>178</b>
<b>CHAPTER 7</b>	
<b>TRANSPORTATION OF PASSENGERS</b>	<b>179</b>

<b>Laws and regulations</b> .....	<b>181</b>
<b>Number of passengers</b> .....	<b>182</b>
<b>Rules for the road</b> .....	<b>183</b>
▶ Picking up and dropping off passengers .....	183
▶ While driving .....	184
▶ Driving on the shoulder .....	185
<b>School buses</b> .....	<b>186</b>
▶ Driver training .....	186
▶ Picking up and dropping off school children .....	187
▶ While driving .....	188
▶ Mandatory equipment .....	188
<b>Securing baggage</b> .....	<b>189</b>
<b>Self-evaluation exercises</b> .....	<b>190</b>

## **CHAPTER 8**

### **TRUCKING 191**

<b>Load restrictions</b> .....	<b>193</b>
▶ Protecting the road network .....	193
▶ Vehicle load and size limits .....	193
<b>Special travel permits</b> .....	<b>197</b>
<b>Safeguarding bridges and overpasses</b> .....	<b>198</b>
<b>Rules for securing cargo</b> .....	<b>200</b>
<b>General rules</b> .....	<b>201</b>
<b>Special rules for the securement of certain types of cargo</b> .....	<b>205</b>
<b>Securement inspection</b> .....	<b>212</b>
▶ Inspection of cargo and the cargo securement system .....	212
<b>Tips for proper load distribution</b> .....	<b>213</b>

<b>Rules for transporting dangerous substances</b> .....	<b>216</b>
▶ Regulations governing the transportation of dangerous substances.....	216
▶ Training drivers to transport dangerous substances.....	216
▶ Shipping document.....	217
▶ Labelling dangerous substances.....	218
<b>Special rules for transporting dangerous substances</b> .....	<b>224</b>
▶ Cargo securement.....	225
▶ Cargo inspection by a peace officer.....	225
▶ Dangerous substances prohibited on road trains.....	226
▶ Transportation of dangerous substances prohibited in certain tunnels.....	226
▶ Mandatory stopping at level crossings.....	228
▶ Accidental spill of dangerous substances.....	229
▶ Transporting liquefied petroleum gas cylinders.....	229
▶ Transportation to the United States.....	230
<b>Safety tips for transporting certain categories of goods</b> .....	<b>231</b>
▶ Livestock.....	231
▶ Dry bulk in tank trucks.....	231
▶ Liquids in tank trucks.....	232
<b>Reflective strips</b> .....	<b>235</b>
<b>Regulation respecting environmental standards for heavy vehicles</b> .....	<b>237</b>
▶ Emission control devices and systems.....	238
▶ Roadside emissions testing.....	239
<b>Self-evaluation exercises</b> .....	<b>240</b>

## **CHAPTER 9**

# **HITCHING, UNHITCHING AND DRIVING A DOUBLE ROAD TRAIN 241**

## **Hitching and unhitching a tractor and a semi-trailer .....243**

- ▶ Hitching a tractor and a semi-trailer  
both equipped with air suspension ..... 243
- ▶ Unhitching a semi-trailer with air suspension..... 248

## **Hitching and unhitching a double road train .....250**

- ▶ Hitching a B train ..... 251
- ▶ Hitching an A or C train ..... 254
- ▶ Unhitching a double road train ..... 258

## **Physical factors that affect driving .....259**

- ▶ Load distribution in the vehicle ..... 259
- ▶ Length of a double road train ..... 260
- ▶ Number of articulations ..... 260

## **Driving a double road train .....261**

- ▶ Driving in a straight line and risk of fishtailing ..... 262
- ▶ Braking ..... 263
- ▶ Negotiating a curve and turning at an intersection ..... 265
- ▶ Passing and avoiding obstacles ..... 268

## **Skidding, overturning and jackknifing .....270**

- ▶ Potential skidding, overturning  
and jackknifing situations ..... 271
- ▶ Tips to prevent jackknifing ..... 272

## **Self-evaluation exercises .....273**

**CHAPTER 10**  
**DRIVING A LONGER**  
**COMBINATION VEHICLE (LCV) 275**

<b>Special operating permit .....</b>	<b>278</b>
▶ Special permit validity period.....	278
<b>Types of LCVs covered by the Regulation ....</b>	<b>279</b>
▶ Characteristics of LCVs .....	280
<b>Roads where LCVs are authorized to travel</b>	<b>283</b>
<b>Roads where LCVs are not authorized</b> <b>to travel .....</b>	<b>283</b>
<b>Responsibilities of special permit holders...</b>	<b>284</b>
<b>Requirements .....</b>	<b>284</b>
▶ Driver's licence.....	284
▶ Horsepower and speed .....	285
▶ Requirements respecting driving days and hours .....	286
▶ Weather conditions.....	286
▶ Transportation of dangerous substances .....	286
<b>Self-evaluation exercises .....</b>	<b>287</b>

**CHAPTER 11**  
**DRIVING AND OFF-DUTY TIME**  
**FOR HEAVY VEHICLE DRIVERS 289**

## CHAPTER 12

### CIRCLE CHECK OF A VEHICLE 345

What is the circle check? .....	347
Is it mandatory? .....	347
Vehicles subject to the circle check .....	348
Exempt vehicles .....	349
Who should perform the circle check? .....	350
Vehicle used by more than one driver .....	351
▶ Successive drivers (one driving after the other) .....	351
▶ Team drivers (alternating driving) .....	352
Who should report defects detected during the trip? .....	353
When should the circle check be performed? .....	353
▶ Special cases .....	354
Responsibility for the condition of the vehicle .....	356
Mechanical defects .....	357
▶ Minor defect .....	357
▶ Major defect .....	357
▶ Lists of defects .....	358
Obligation regarding the list of defects .....	359
Components to inspect .....	360
The inspection report .....	361
▶ Is it mandatory? .....	361
▶ What should it include? .....	362
▶ Example of an inspection report .....	363
▶ When should a defect be reported? .....	364
▶ When should the inspection report be handed in? .....	365
▶ Driving in Canada and the United States .....	365

## **Drivers and the circle check.....366**

## **Table of components to inspect and defects to be detected .....367**

1 - Coupling Devices .....	369
2 - Frame and Cargo Body .....	377
3 - Heater/Defroster.....	380
4 - Driver Controls.....	381
5 - Steering.....	384
6 - Windshield Wiper/Washer .....	387
7 - Emergency Material.....	388
8 - Headlights and Lights.....	391
9 - Tires .....	396
10 - Doors and Other Openings .....	399
11 - Glass and Mirrors .....	401
12 - Wheels, Hubs and Fasteners.....	404
13 - Seat .....	407
14 - Suspension .....	408
15 - Fuel System .....	412
16 - Exhaust System .....	413
17 - Electric Brake System.....	414
18 - Hydraulic Brake System .....	415
19 - Pneumatic Brake System.....	420
20 - Passenger Transport.....	427

## **For a thorough and effective inspection .....433**

## **Tips and recommendations .....434**

- ▶ Choose a safe location..... 434
- ▶ Make sure the vehicle is stable..... 434
- ▶ Access the vehicle using three support points..... 435
- ▶ Items requiring special attention..... 435
- ▶ Pay attention to your vehicle's overall condition..... 435
- ▶ Adapt your method to the vehicle..... 436







<b>Suggested 10-step method</b> .....	<b>436</b>
1 - Approaching the vehicle and preliminary cab check .....	438
2 - Front of the tractor truck .....	439
3 - Left side of the tractor truck (driver's side) .....	439
4 - Centre left side of the semi-trailer (driver's side) .....	441
5 - Rear left side of the semi-trailer (driver's side) .....	442
6 - Rear of the semi-trailer .....	442
7 - Rear right side of the semi-trailer (passenger's side) .....	443
8 - Centre right side of the semi-trailer (passenger's side) .....	443
9 - Right side of the tractor truck (passenger's side) .....	444
10 - Inside the cab (driver's compartment) .....	446
<b>Inspecting a pneumatic brake system (air brake system)</b> .....	<b>447</b>
<b>Inspecting a hydraulic brake system</b> .....	<b>450</b>
<b>Particularities for inspecting other types of vehicles</b> .....	<b>453</b>
▶ Straight-body trucks (or straight-body trucks hauling a trailer) .....	453
▶ Buses and motor coaches .....	454
▶ City buses .....	454
▶ School buses .....	455
▶ Motor coaches .....	455
<b>Inspections while on the road</b> .....	<b>456</b>
<b>Inspections during your trip</b> .....	<b>457</b>
<b>Roadside inspections</b> .....	<b>458</b>
<b>Inspections at the end of a trip</b> .....	<b>458</b>
<b>Self-evaluation exercises</b> .....	<b>459</b>

<b>APPENDICES</b>	<b>461</b>
<b>Driver's licence classes</b> .....	<b>462</b>
▶ Class 1 .....	462
▶ Class 2 .....	463
▶ Class 3 .....	463
<b>Lists of defects</b> .....	<b>465</b>
▶ List 1 – Heavy Vehicles.....	465
▶ List 2 – Buses.....	473
▶ List 3 – Motor Coaches .....	481
<b>Laws and regulations</b> .....	<b>488</b>
▶ Laws .....	488
▶ Regulations.....	488
<b>Documents and publications</b> .....	<b>489</b>
▶ Société de l'assurance automobile du Québec.....	489
▶ Ministère des Transports du Québec .....	490
▶ Commission des transports du Québec.....	490
<b>Pressure conversion table</b> .....	<b>491</b>
<b>Measurement conversion table (length)</b> .....	<b>492</b>
<b>Answers to the questions at the end of each chapter</b> .....	<b>493</b>
<b>NOTES</b>	<b>495</b>



# HOW TO USE THIS GUIDE

The following symbols will help you use this guide more efficiently.

Icon	Meaning
	<b>IMPORTANT!</b> Important safety information
	<b>THINK ABOUT IT!</b> Things you need to consider in order to become a competent driver
	<b>TOOLBOX</b> Additional information on the subjects discussed
	<b>THEORETICAL EXERCISES</b> Exercises that allow you to check what you have learned

# THE DRIVER'S RESPONSIBILITIES

1

Road safety is in large part the driver's responsibility. When an accident occurs, it is usually the driver who, rightly or wrongly, is held to blame and not the vehicle, the condition of the road, or other factors.

It is therefore important for you to be very familiar with and obey the laws and regulations that govern traffic and highway transportation. You must also develop behaviours that will make you a safe driver. In particular, you must adjust your driving style to the kind of vehicle you are driving, to the type of cargo you are transporting or to the fact that you are carrying passengers. Unexpected hazards can arise at any time when you are driving, so you have to know what to do and be able to react to whatever comes your way.

Understanding your rights and the rights of other road users and meeting your obligations will help you become a truly professional driver.

# HABITS YOU MUST DEVELOP

## Seat belts

In Québec, drivers of heavy vehicles must wear the seat belts installed by the vehicle manufacturer. Statistics prove that this greatly reduces the number of deaths and the seriousness of injuries caused by traffic accidents.

Whether an accident involves one or more vehicles, seat belts protect drivers by preventing them from hitting the steering wheel or windshield and from being thrown from their vehicle.

## Alcohol and drugs

In Québec, you are prohibited from driving a heavy vehicle if you are impaired by alcohol or drugs. Any driver with a blood alcohol level of 80 mg of alcohol per 100 ml of blood (0.08) or more and who is driving while impaired is subject to the penalties and measures prescribed by the *Criminal Code* and the *Highway Safety Code*.

## Zero tolerance

If you have alcohol in your blood, you may not drive a bus, minibus or taxi. If you have alcohol or drugs in your blood, or may you have any such vehicle in your care or control. If you violate this zero-tolerance rule, you are prohibited from driving any such vehicle for 24 hours.

## Blood alcohol limit of 0.05

If you have a blood alcohol concentration of 0.05 or more, you are prohibited from driving a heavy vehicle (other than those covered by the zero-tolerance rule spelled out in the previous paragraph), a tow truck or a vehicle requiring the display of safety mark placards pursuant to the the *Regulation respecting hazardous materials*. You are also prohibited from having any such vehicle in your care or control. This restriction does not apply, however, to a combination of vehicles formed by a passenger vehicle pulling a house trailer or tent trailer, or to a motor home.



Remember that alcohol or drugs and driving don't mix!

## Electronic devices and driving

Simply holding any kind of portable electronic device in your hand while driving is illegal, regardless of how you are using it. This restriction does not apply, however, to the driver of an emergency vehicle when on duty.

The law applies to all devices, whether or not they are in use, such as:

- ▶ Cell phones (including those with a transmitter-receiver function);
- ▶ MP3 players or portable multimedia players;
- ▶ Portable satellite radios;
- ▶ Electronic tablets;
- ▶ Screens that display information that is not of use when driving;
- ▶ Devices that display emails and make it possible to browse the Internet.



## Screens and driving

GPS (Global Positioning System) has become more and more popular in recent years. While very useful for directions, it remains a potential source of distraction for the driver. It must therefore be used with discernment. If you need to program the system or enter information, do so before leaving. The same applies when using an electronic log book, which must only be used when the vehicle is parked in a safe location.

## The meaning of the expression “while driving”

A driver who brings his or her vehicle to a stop to comply with signage or due to traffic is still considered to be driving. The individual is considered to be controlling a vehicle while obeying road signs and traffic signals or while waiting for traffic to resume. A driver who is waiting at a red light or in a traffic jam is considered to be driving a vehicle and therefore cannot use a hand-held electronic device.

A driver who brings a vehicle to a safe and legal stop by the side of a road in order to use a portable electronic device is no longer considered to be driving, even if the vehicle's engine is still running.

## CBs are authorized

This restriction does not apply to devices installed in the vehicle in such a way that only the microphone or receiver is held in the hand. This exemption covers shortwave two-way radios that do not allow both parties to talk simultaneously, more commonly known as CBs or walkie-talkies.

## Headrest adjustment

Headrests, like seat belts, are effective in preventing injuries. Most heavy vehicles have seats with a stationary headrest, but some have an adjustable headrest and the driver should adjust it properly before taking to the road. By taking this precaution, you can avoid whiplash or a painful neck injury in the event of a collision.

## At the wheel

As a professional driver of heavy vehicles, you have many responsibilities. Whether you are carrying cargo or people, you must adopt certain attitudes in order to accomplish the exacting and complex task of driving a heavy vehicle. When driving on public roads, you must also exercise caution and show respect in the presence of more vulnerable people.

## Cooperate

Drivers must share the road with other users and must learn to cooperate. Having a cooperative and courteous attitude means that you make driving easier for others and avoid reckless actions that might endanger them.

### EXAMPLES OF COOPERATIVE BEHAVIOUR:

- ▶ Adjusting your speed to allow another driver to pull over into your lane more easily.
- ▶ Using the right lane and reserving the left lane for passing.

## Keep your cool

Professional drivers have a duty to stay calm, collected and cooperative in all situations.

If another road user, with or without provocation, is acting aggressively toward you, the best response is to avoid needless confrontation by staying calm and obeying the rules of the road. By reacting this way, you will force the other driver to the realization that it is useless trying to provoke you.

## Stay alert

Failure by the driver to pay attention is the cause behind most accidents resulting in bodily injury and involving a truck. Fatigue, distraction, anger, frustration, stress, alcohol, medication and drugs are all common causes of inattention, although fatigue is recognized as the main cause.

There are also certain monotonous aspects of driving that can provoke an almost hypnotic state. The layout of the road, over-familiarity with a route too frequently driven, and driving for long hours can all lead to "highway hypnosis". If you find this happening to you, pull over as soon as you can to rest for a while. After that, take a break from time to time, every two hours if possible, or whenever you feel the need to stop.



## Anticipate

Anticipating means planning ahead based on what is happening now and what the current road environment is like. You have to remain attentive to what is going on around your vehicle, but also be prepared for any unexpected hazards that might otherwise catch you off guard.

To do this, you should make it a habit to employ the following strategies:

**SCAN** your environment and **OBSERVE** attentively what is happening on and near the road to avoid any surprises and any risk of collision with another vehicle. You have to become a careful observer in order to drive safely and responsibly. Do not stare at a single fixed point up ahead on the road; instead, look at what is going on up ahead, to the sides and in your mirrors.

**IDENTIFY** potential dangers that pose a risk of accident. You have to read the road. Road signs enable you to adjust your speed to the road environment. By maintaining enough space between your vehicle and other road users, you can help ensure you will have enough time to react if an unexpected hazard arises.

**DECIDE** what is the best course of action to prevent a collision: for example, slow down, stop, change lanes or direction, or even sound your horn. Before setting out, you should know your route, what kind of cargo you are carrying and what kind of road conditions you will be facing: this will help you decide how to react.

**ACT** by performing the right manoeuvre at the right moment. Professional drivers encounter countless situations that force them to make quick decisions. If you have acquired the proper knowledge and skills, you will be that much better prepared when something unexpected occurs.

### A GOOD EXAMPLE TO FOLLOW...

Mark, an experienced driver, is driving in the city and scans the road to the front and sides of his vehicle. He sees that the traffic light ahead has been green for a while and anticipates that it will turn red before he reaches the intersection. He therefore starts to slow down in case he needs to stop. By observing the road environment, traffic lights and road signs in advance, just like Mark, you will have the time you need to react.

## RULES

Drivers of heavy vehicles are required to obey many laws and regulations. Under the **Highway Safety Code**, for instance, they must make sure their vehicle undergoes an inspection each day and at predetermined intervals. This is what is known as a *circle check*.

The **Regulation respecting hours of driving and rest of heavy vehicle drivers** was adopted in order to cut down on the risk of accidents involving heavy vehicle drivers. These regulatory provisions also affect operators since they must ensure that the drivers they employ are able to drive safely.

The **Vehicle Load and Size Limits Regulation** sets out various standards limiting size, load per axle group and total loaded mass for vehicles on public roads. Vehicles that do not meet the standards prescribed by this regulation are considered oversized or overloaded vehicles and cannot use public roads unless their owner or operator has a special permit issued for that purpose.



For more information on special permits, visit the website of the Ministère des Transports du Québec ([www.transports.gouv.qc.ca](http://www.transports.gouv.qc.ca)).

Drivers who **transport dangerous substances** need to be aware of the applicable legislative requirements before they take to the road. They must have received training for transporting dangerous substances and make sure they have an employer's certificate proving they have received such training.

**School bus drivers** also must receive training on school children safety and hold a certificate of competency proving they have received such training.

In addition, if you are going to be driving outside Québec, make sure that you are familiar with the laws and regulations in force in the states and provinces where you will be travelling. Heavy vehicle drivers in the United States, for instance, must be at least age 21. In some jurisdictions, the driving hour requirements, as well as the classification of major and minor defects, may be different.

# SPRING THAW RESTRICTIONS

1

During the thaw each spring, road resistance decreases by 40% and roads become especially vulnerable to the weight of heavy vehicles. Each time a truck drives over a road during spring thaw, its impact on the pavement is equivalent to that of several trucks during normal weather conditions. Limiting loads is therefore more important at that time.

A single overloaded truck travelling at that time of year can cause serious road damage. This is the reason for enforcing stricter load limits during spring thaw.



The load restriction period is usually from March to May, but beginning and end dates can be adjusted earlier or later depending on weather conditions.

Load restrictions apply throughout Québec but differ from region to region. To determine the maximum authorized weight limit during spring thaw and to factor in weather conditions according to region, Québec is divided into three major zones, as illustrated below:

▶ **Zone 1**

covers southern Québec, which includes the urban areas of Gatineau, Montréal, Sherbrooke, Trois-Rivières and Québec, and extends to Rivière-du-Loup.

▶ **Zone 2**

is located directly north of zone 1 and includes the La Vérendrye and Laurentides wildlife reserves along with Témiscamingue, Saguenay, Lac-Saint-Jean, Côte-Nord, Rimouski, Gaspésie and Îles-de-la-Madeleine.

▶ **Zone 3**

is located north of zone 2 and includes Abitibi, the Chibougamau-Chapais region and Ashuapmushuan wildlife reserve.

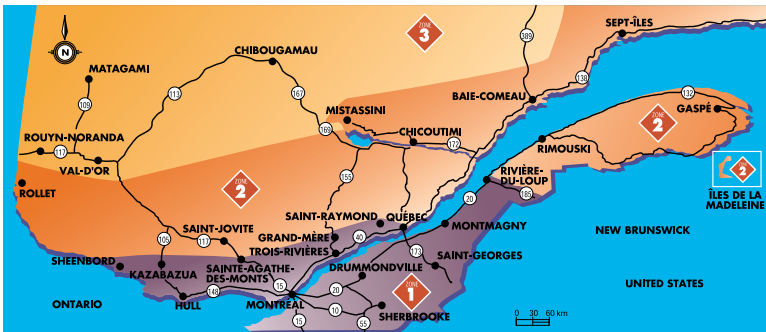



All heavy vehicles are subject to these temporary weight restrictions. Heavy vehicle operators are required to comply with specific weight restrictions during the spring thaw period. Load limits (total loaded mass) are based on the vehicle's configuration and the type of axle used. Authorized load limits are listed in the *Vehicle Load and Size Limits Regulation*.

Zones and spring thaw periods can vary from year to year. That is why it is important to consult Transport Québec's information service and information bulletins for details about load limits.

## HIGHWAY CARRIER MONITORING

The Société de l'assurance automobile du Québec (SAAQ) has been assigned the mandate of ensuring that vehicles carrying passengers or goods within Québec's territory comply with the applicable regulations. The SAAQ plays an essential role in ensuring road safety, protecting infrastructures and guaranteeing fair competition.



To fulfill its mandate, Contrôle routier Québec, among its other responsibilities, is tasked with ensuring that heavy vehicle operators comply with the laws and regulations governing their activities, such as the *Highway Safety Code*, the *Transport Act* and the *Act respecting owners, operators and drivers of heavy vehicles*.

As a heavy vehicle driver, you may be subject to a roadside inspection. In such a case, you are required to stop your vehicle and cooperate with the peace officer. An inspection may cover the following points:

- ▶ driver's licences;
- ▶ vehicle registration;
- ▶ registration in the Register of owners and operators of heavy vehicles;
- ▶ transport permits;
- ▶ bills of lading (information on the goods carried and the trip);
- ▶ leasing contracts;
- ▶ hours of driving and on-duty and off-duty time;
- ▶ circle checks;
- ▶ mechanical condition;
- ▶ vehicle weight and size;
- ▶ registration with Revenu Québec (International Fuel Tax Agreement or IFTA);
- ▶ load securement;
- ▶ transportation of dangerous substances;
- ▶ compliance with traffic rules and regulations.

# MANDATORY STOPS AT INSPECTION STATIONS

1

You are required to stop at an inspection station when its lights are flashing if you are driving:

- ▶ a vehicle with a gross vehicle weight rating (GVWR) of 4,500 kg or more that is designed and equipped primarily for the transportation of goods or for the transportation of equipment that is permanently attached to the vehicle;
- ▶ a tow truck or a tool vehicle;
- ▶ a combination of road vehicles (a truck hauling a trailer, for example), where at least one of the vehicles has a GVWR of 4,500 kg or more.

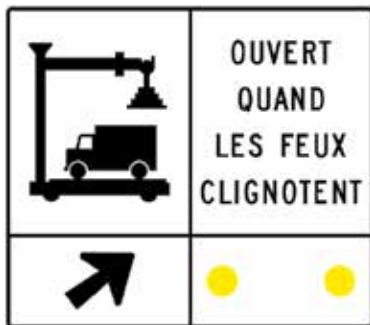

Certain exceptions apply, in particular for trucks with a net weight of 4,000 kg or less registered as a passenger vehicle within the meaning of the regulations on vehicle registration, or for road vehicles used for recreational purposes.

# OBLIGATIONS

Various safety standards apply to road transportation and the resulting responsibilities fall not only on the owner and operator, but also on the driver.

Note that the *Act respecting owners, operators and drivers of heavy vehicles* also applies to certain vehicles that are defined as “heavy vehicles” by the Act but do not require a Class 1, 2 or 3 driver’s licence.

Drivers of the following vehicles are subject to these same obligations regardless of the class of driver’s licence they hold:

- ▶ equipment transport vehicles with a GVWR of 4,500 kg or more;
- ▶ emergency vehicles with a GVWR of 4,500 kg or more;
- ▶ combinations of road vehicles including at least one vehicle with a GVWR of 4,500 kg or more;
- ▶ tow trucks (regardless of GVWR);
- ▶ buses (regardless of GVWR);
- ▶ vehicles carrying dangerous substances that require the display of safety mark placards (regardless of GVWR).

The standards governing heavy vehicle drivers are summarized in the following list, which is arranged by subject matter. They are explained in depth in the following chapters.

## Circle check

- ▶ Do a sound and sight check of your vehicle's condition and record your observations (major or minor defects) in the circle check report.
- ▶ Keep the circle check report up to date.
- ▶ Keep the circle check report in your vehicle.
- ▶ Report any mechanical defects and anomalies in writing.
- ▶ Make sure the vehicle you are operating has no major defects.

## Transportation of passengers and goods

- ▶ Comply with the legal passenger limit.
- ▶ Arrange and secure baggage, cargo and mail properly in designated bus compartments.
- ▶ Properly secure the load on a truck.
- ▶ Obey the regulations governing the transport of dangerous substances, including the prohibition on driving through tunnels.

## Driver's licence

- ▶ Inform the operator if your licence or the licence class and endorsements authorizing you to drive the vehicle is modified, cancelled or suspended.
- ▶ Comply with the requirements of any peace officer who suspends your licence or your right to drive certain vehicle classes because you have exceeded the number of driving or on-duty hours prescribed by regulation, or you have been driving with a licence that was not valid or while you were impaired (drugs, alcohol or fatigue).
- ▶ Hold only one driver's licence of the class and with the endorsements required for driving the vehicle in question. Refer to the **Driver's licence** section of this guide for more information.

## Driving and off-duty hours

- ▶ Unless you have been exempted, keep accurate off-duty and driving time logs in your vehicle for the previous 14 days, regardless of the cycle you are following.

## Vehicle registration

- ▶ Have the vehicle's registration certificate and proof of insurance coverage in your possession.

## Vehicle and equipment

- ▶ Buckle up and refrain from driving your vehicle if the seat belt is missing, has been altered or is not in working order.
- ▶ Use a flashing or rotating yellow light, as needed, in accordance with the conditions of your special travel permit.
- ▶ Put a red flag or reflective panel and, at night, a visible red light on the rear end of an oversized load if it extends more than one metre beyond the rear of the vehicle.
- ▶ Keep safety equipment (emergency warning triangle and reflectors, flares or lamps).



## Vehicle size and load

- ▶ Have in your possession a special travel permit for an oversized or overloaded vehicle.
- ▶ Comply with the conditions of the special travel permit.



## Roadside inspections and facility audits

- ▶ Obey instructions from peace officers (police or carrier enforcement officers).

# IN THE EVENT OF AN ACCIDENT

If you are involved in an accident, you have certain responsibilities under the *Highway Safety Code*. First of all, you must remain at the scene of the accident or return to it immediately. If anyone is injured, you must help the victim in any way you can and contact the police. You must also provide any information required by the police officer who comes to the scene.

Since you spend a lot of time on the road, at some point you may be the first person to arrive at the scene of an accident.

If you are a witness to an accident or the first person to arrive at the accident scene, you can be of help. Park your vehicle by the side of the road about 30 m from the scene and turn on your emergency lights. Contact the police immediately or have someone else do so as soon as possible. If anyone is injured, turn off the ignition of the vehicle involved as a safety precaution. If possible, set out flares or reflectors to warn other road users.

If you remain at the scene of an accident where persons have been injured, try to assist them as best you know how. A first-aid training course is a good way of acquiring practical knowledge for such situations. It is also a good idea to keep a first-aid kit in your vehicle at all times.



On arriving at the scene of an accident and for as long as you remain there, make sure you can provide assistance without endangering yourself or others.

# MOVE-OVER LAW

Because of their size, heavy vehicles represent a particular danger for road workers. As a heavy vehicle driver, you must remain alert to their presence.



This is why a measure has been introduced, referred to as the “Move-Over Law,” requiring you to respect a buffer zone around an emergency vehicle (police vehicle, ambulance, fire department vehicle or Contrôle routier Québec vehicle), a tow truck or any other type of vehicle if:

- ▶ it is stopped
- and
- ▶ its yellow arrow light signal, rotating lights or flashing lights are activated.

Slow down and change lanes to move over as far as possible from the stopped vehicle, after you have made sure that you can do so safely. If circumstances so require, stop your vehicle.

 To learn more, visit [www.corridorde securite.gouv.qc.ca](http://www.corridorde securite.gouv.qc.ca) (French only).

# IN THE PRESENCE OF ROAD WORK

As a heavy vehicle driver, you must pay attention to the signs installed near and on road work sites. Observe the speed limit indicated on the orange sign, as you would the speed limit on a white road sign.

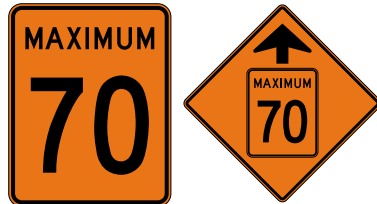



Look far ahead to check whether there are any changes in traffic or if a part of the road is blocked. Due to road work, a part of the highway might also have to accommodate two-way traffic over several kilometres. Do not brake suddenly if you need to change lanes.

## IN THE PRESENCE OF A FLAGPERSON

The flagperson directs traffic on a road where construction or maintenance work is being carried out. The flagperson uses an eight-sided sign with “Arrêt” (Stop) on one side and “Lentement” (Slow) on the other.

► **“Arrêt” Sign**

You must stop and wait for the flagperson to signal you to proceed.

► **“Lentement” Sign**

You must slow down and proceed with caution. You must also maintain an adequate distance from the flagperson and not endanger any person or vehicle on the site.



See the section entitled “Road Signs” in the *Driver's Handbook*.

# SELF-EVALUATION EXERCISES



## Theoretical Exercises

### True or false

---

1. Indicate whether the following statements are true or false.

	True	False
1. In Québec, heavy vehicle drivers must wear the seat belt installed by the vehicle manufacturer.	<input type="checkbox"/>	<input type="checkbox"/>
2. The <i>Highway Safety Code</i> requires heavy vehicle drivers, when doing a circle check, to do a sight and sound check and record their observations in the circle check report.	<input type="checkbox"/>	<input type="checkbox"/>
3. Drivers of a straight-body truck weighing 4,500 kg or more are not required to stop at an inspection station to have their vehicle and documents checked when the station's lights are flashing.	<input type="checkbox"/>	<input type="checkbox"/>
4. During spring thaw, a different load restriction period applies in each zone.	<input type="checkbox"/>	<input type="checkbox"/>
5. Drivers who have been involved in an accident are required to remain at the scene.	<input type="checkbox"/>	<input type="checkbox"/>

Answers at the end of the guide.

# FACTORS THAT INFLUENCE DRIVING

2

---

A number of factors may have an impact on driving a vehicle. These include driver behaviour, vehicle characteristics and your driving situation, in particular, weather conditions and traffic density.

You must therefore adjust your driving as dictated by these factors. By exercising caution and employing the suggested techniques, you will develop the skills and habits of a real professional.

# DRIVER FATIGUE

Driver fatigue is one of the leading causes of traffic accidents, along with speeding, distraction and alcohol.

An in-depth study carried out in the United States shows fatigue to be one of the primary causes of fatal accidents for heavy vehicle drivers. In many such fatalities, health problems related to insufficient or poor-quality sleep are a contributing factor.

## Effects of fatigue on driving

Regulating the number of driving hours and off-duty hours for heavy vehicle drivers is not enough by itself to eliminate the risk of fatigue-related accidents.

It is important to remember that fatigue becomes a problem when it compromises an individual's ability to perform tasks that require attention, judgment and sharp reflexes. Fatigue can:

- ▶ reduce your alertness, concentration and attention;
- ▶ alter your judgment and the quality of your decision-making;
- ▶ slow your reaction time;
- ▶ impair your memory;
- ▶ lead to drowsiness, microsleep periods and actually falling asleep at the wheel.

## Learning to recognize the signs

The warning signs of fatigue should be taken seriously. You should stop immediately in a safe location to rest when the first signs appear.

The signs of fatigue vary from one individual to another, but it is essential you learn to recognize them:

- ▶ yawning frequently and blinking excessively;
- ▶ nodding off;
- ▶ straying into the adjacent lane;
- ▶ being slow to brake;
- ▶ having difficulty keeping a constant speed;
- ▶ not remembering the last few kilometres travelled;
- ▶ missing an exit;
- ▶ being unable to find a comfortable position;
- ▶ feeling irritable;
- ▶ experiencing hallucinations;
- ▶ failing to check the rearview mirrors.

## Three factors determining fatigue

These three factors are:

- ▶ **the driver:** your state of health, in particular, whether you have a sleep disorder, the quality of your sleep, the type of individual you are (early bird or night owl), your age, emotional state, diet, level of physical fitness, family or personal life, whether you work one or more jobs, etc.;
- ▶ **the work environment:** frequent schedule changes, long hauls, interrupted schedules, night work, waiting times, length of work day, physical exertion, company policies with respect to managing fatigue, etc.;
- ▶ **the physical environment:** weather and road conditions, the availability of rest areas, the effects of noise, lighting and temperature in the cab, vehicle ergonomics, etc.

## Aggravating factors

To effectively determine an individual's exposure to fatigue, it is important to consider the following principal factors.

### Time of day

The risk of falling asleep at the wheel is greatest early in the afternoon between 1:00 p.m. and 3:00 p.m. and at night between midnight and 6:00 a.m. The body follows a daily cycle that includes "down" periods during which metabolism slows down, alertness declines and fatigue sets in.



Fatigue-related accidents according to time of day – effect of the biological clock

Source: Mitler, MM., et al. (1988).

## Number of hours without sleep

After 17 hours without sleep, your physical and mental performance declines rapidly, affecting your driving. After 17 to 19 hours without sleep, your physical and mental capacities are equivalent to your having a blood alcohol concentration of 0.05 (50 mg of alcohol per 100 ml of blood). After 24 hours without sleep, your capacities are equivalent to your having a blood alcohol concentration of 0.10 (100 mg of alcohol per 100 ml of blood).

## Accumulated sleep debt

Regardless of age, if you do not get enough sleep, you build up a “sleep debt.” Your performance may begin to suffer after even a single night without enough sleep. Most adults need 7 to 9 hours of sleep each night to feel rested and alert.

The only way to remedy a sleep debt is to get enough sleep. And contrary to what some may think, your body cannot compensate for missed sleep over the long term. So, avoid building up a sleep debt.

## Sleep disorders

There are dozens of different sleep disorders. A person with a sleep disorder may feel abnormally tired and sleepy.



Obstructive sleep apnea is an illness affecting at least 10% of the population. Even though it may have a very negative impact on a person's health and quality of life, a large percentage of those affected are unaware of their problem. The condition is characterized by total or partial obstruction of the throat that recurs frequently during the night. The obstruction reduces the level of oxygen in the blood and disrupts the individual's sleep. This phenomenon can repeat itself hundreds of times in a single night. As a result, a person suffering from sleep apnea is unable to achieve a deep enough level of sleep to feel rested the next day.

The symptoms of sleep apnea are snoring, agitated sleep and frequently waking up during the night due to a feeling of suffocation. During the daytime, sufferers feel sleepy or tired, suffer from a shortage of energy and morning headaches, and have memory and attention problems. They do not feel rested in the morning. Certain illnesses, such as type II diabetes, hypertension, depression and cardiovascular disease, can lead to sleep apnea. To find out how to treat this sleep disorder, you should see your doctor.



Consumption of alcohol, medications or drugs greatly amplifies the effects of fatigue and the accumulation of a sleep debt.

## Noise

Noise, which varies depending on the environment and the type of vehicle, is a factor that magnifies the fatigue to which drivers are subject: noise from the engine, the tires, the exhaust system, the radio or the cab itself. A cab that is inadequately soundproofed, the vehicle's speed and, of course, playing the radio at high volume all add to the noise level and contribute to driver fatigue.

## Recommendations for managing fatigue

### AT HOME

- ▶ Seek the support of your family and make your sleep a priority.
- ▶ Plan enough free time to ensure restorative sleep.
- ▶ Ask family members not to disturb you when sleeping.
- ▶ Exercise regularly; even just 15 minutes of exercise a day is beneficial.
- ▶ Watch your diet: eat light low-fat meals and at least 5 to 10 servings of fruits and vegetables each day, with a low salt and sugar intake.
- ▶ Watch your caffeine and alcohol consumption.
- ▶ Take time out each day to relax and take steps to manage your level of stress.
- ▶ As a general rule, be aware of your sleep needs and make sleep a priority!
- ▶ See your doctor if you need help with sleep disorders.

### ON THE ROAD

- ▶ Begin the work day well rested.
- ▶ Plan your route so that you can take advantage of as many opportunities to sleep and rest as possible. Ideally, you should take a break every two hours and a nap whenever necessary.
- ▶ Whenever possible, avoid driving at night between midnight and 6:00 a.m. and during the day between 1:00 p.m. and 3:00 p.m.
- ▶ Slow down! Travelling at higher speeds requires you to process more information faster, which in the long term can lead to fatigue.
- ▶ Avoid visual fatigue while driving: dim the dashboard lights and remove objects that are reflected in the windshield.
- ▶ Assess your degree of fatigue and notify your dispatcher if necessary.

**Respect your limits for the sake of your own safety and that of others! Fatigue is not something you can fight against. Be alert for the first signs of fatigue and pull over to a safe location as soon as possible to rest.**

## For more information

To find out more, refer to:

- ▶ the *Fatigue Management Guide*  
[saaq.gouv.qc.ca/en/publications](http://saaq.gouv.qc.ca/en/publications)
- ▶ the North American Fatigue Management Program  
[saaq.gouv.qc.ca/pnagf](http://saaq.gouv.qc.ca/pnagf)

## INATTENTIVENESS

Drivers who are tired can make errors and cause serious accidents. You must therefore pay attention to the warning signs of fatigue that your body is sending you.

The inattentiveness that results when driving along roads that have monotonous surroundings and require little manoeuvring can lead to a condition referred to as “highway hypnosis” and can even cause you to fall asleep at the wheel.

## DISTRACTIONS

Distractions decrease a driver’s vigilance and performance. You must therefore avoid external distractions such as smoking, eating, drinking, using electronic devices, or any other activity that can turn your attention away from the road. A distracted driver is processing only half of the information available from the environment. He or she looks, but is not seeing what is happening.

# SPEED

Speeding and reckless driving are major causes of fatal accidents involving heavy vehicle drivers. Drivers must therefore obey minimum and maximum speed limits or face penalties.

Speeding creates a series of conditions that can increase driver stress and affect how you drive. Speeding has the following effects on driving:

- ▶ As you speed up, your field of vision gradually shrinks and your vision becomes very much like it would be if you were driving through a narrow tunnel. This is because of the increased speed at which objects are passing by you on either side of the vehicle.
- ▶ The distance travelled by the vehicle during reaction time increases.
- ▶ Braking distance increases.
- ▶ Your ability to make evasive manoeuvres declines.

Always bear in mind that you are driving a heavy vehicle, so it is important to drive responsibly at all times.

In large cities, traffic is often slow, so even if you are in a hurry to reach your destination, you must remain calm. You should also be extra careful and patient and use common sense, because in such a situation some road users may become aggressive and behave recklessly and dangerously.

# ALCOHOL

# 2

Alcohol affects the brain and the central nervous system, which is the body's decision-making and coordination centre. As blood alcohol concentration increases, your ability to drive is gradually diminished.

Driving under the influence of alcohol:

- ▶ changes the quality of your visual perception;
- ▶ alters your judgment;
- ▶ increases your reaction time;
- ▶ reduces your resistance to fatigue;
- ▶ impairs your coordination.

Furthermore, an individual who is under the influence of alcohol also feels more self-confident, which leads to more risk-taking at the wheel and more dangerous driving. Even now, alcohol is still the cause of numerous fatalities and thousands of injuries on Québec's roads.

Under the *Criminal Code*, the legal limit is 80 mg of alcohol per 100 ml of blood (0.08). Penalties for driving while impaired by alcohol are increasingly severe with serious consequences. Even where an individual's blood alcohol concentration is below the legal limit, the ability to drive is diminished. It is also important to understand that **you can be arrested and convicted even if you have a blood alcohol concentration below 0.08**, if there is enough evidence to establish that your ability to drive has been impaired as a result of alcohol, drugs or medication. Drivers of heavy vehicles are also subject to special rules concerning blood alcohol concentration while driving (see Chapter 1).

Certain folk remedies that supposedly reduce or eliminate the effects of alcohol are ineffective. Some people believe that eating at the same time they drink alcohol helps eliminate alcohol from their system. To a certain degree eating may delay the absorption of alcohol into the bloodstream. It does not, however, prevent intoxication but merely slows the process. Regardless of your blood alcohol concentration, the liver eliminates 15 mg of alcohol an hour on average, which is equivalent to one beer, one glass of wine or one serving of spirits. The fact is, only time can eliminate alcohol from the bloodstream and mitigate its effects on driving.

## DRUGS AND MEDICATIONS

Like alcohol, drugs and certain medications affect the brain and impair your ability to drive.

Drugs are classified according to their effects on the central nervous system (CNS). The three main categories of drugs are depressants, stimulants and CNS disrupters. The effects of drugs can vary from one person to another and even from one occasion to another. Furthermore, the effect a drug produces depends on the characteristics of the individual, the product consumed and the context in which it was used.



Use of illegal drugs is on the rise in Canada and the drug of choice is cannabis. Consumption of cannabis may have the following effects on your ability to drive a motor vehicle:

- ▶ difficulty concentrating and paying attention to the road environment;
- ▶ diminished perception of your surroundings;
- ▶ loss of coordination;
- ▶ difficulty driving in a straight line;
- ▶ difficulty driving at a constant speed and evaluating distances;
- ▶ slower reaction time, slower reflexes and hesitant driving;
- ▶ potential inability to cope with unexpected hazards.

Stimulants such as cocaine, speed and amphetamines give drivers a false sense of confidence and can lead to more risk-taking (speeding, aggressiveness). They also lead to drowsiness and a lack of concentration after the initial phase of euphoria has passed. It is thus an error to believe that this type of drug can ward off fatigue.

A Québec study conducted between 1999 and 2002 revealed that almost 25% of all drivers killed in traffic accidents had drugs in their system at the time of death. Among these, approximately half had also consumed alcohol. Combining alcohol and drugs significantly increases the risk of being involved in a fatal traffic accident. This is an extremely dangerous practice that should be avoided at all costs.

Some prescription and over-the-counter medications can alter your ability to drive by diminishing your alertness, attention, vision or balance and by affecting behaviour. The following categories of medications can affect driving:

- ▶ Sedatives
- ▶ Minor tranquilizers
- ▶ Pain medications
- ▶ Cough and cold medications
- ▶ Hypnotic drugs
- ▶ Diabetes medications

You should consult a health care professional (physician, pharmacist) to find out how these medications will affect your ability to operate a vehicle, and you must always carefully read the instructions that come with prescription or over-the-counter medications.



# CERTAIN FEATURES OF YOUR VEHICLE AND THEIR IMPACT ON YOUR DRIVING

## Vehicle size and weight

A vehicle's size and total loaded mass may affect your driving, speed and stopping distance. You will have to take these factors into consideration so as to be ready to react to unexpected hazards as they arise.

For example, Chapter 5 explains that you must bear in mind the size of your vehicle when turning or going through an intersection so as to allow enough space and not cause problems for other road users.

In addition, the load you are carrying has an impact on your vehicle's stability, accelerating power and stopping distance. You must therefore leave enough space between you and other vehicles when entering the stream of traffic, changing lanes, passing other vehicles or stopping.

Considering the importance of all these factors, it is only natural that you, the driver, should share responsibility with the operator for complying with the provisions of the *Vehicle Load and Size Limits Regulation* applicable to road vehicles and combinations of road vehicles. For further information on how the Regulation applies to various heavy vehicles and their loads, refer to Chapters 8, 9 and 10.

## Condition of the tires

Heat affects different vehicle components. For instance, it causes tires to wear out more quickly. The internal temperature of a tire can rise very high, making the rubber less resistant to cuts and tears and increasing the risk of a flat.

The tires merit special attention because they are a very important component of your vehicle.

They have to bear the vehicle's weight, absorb shocks resulting from rough road surfaces, and perform well when you are accelerating, turning and braking, winter or summer, day in day out.

In summer, pay close attention to the tire treads because they tend to crack or become unstuck in intense heat. Heat also increases tire pressure, but do not let any air out of them because the pressure will then be too low once the tire has cooled down. If any of the tires feel very hot to the touch, you should wait a while and let them cool down before driving again. Otherwise, the tire could have a blowout or catch fire.



For your own safety and that of others, check the tires regularly when doing your circle check. If the weather is very hot, check them even more frequently. See Chapter 12 for applicable check schedules.

## Checking fluids in hot weather

During hot weather, you should also regularly check:

- ▶ the engine oil pressure gauge;
- ▶ the engine coolant temperature gauge;
- ▶ the transmission fluid temperature gauge;
- ▶ the differential fluid temperature gauge.

## Getting your vehicle ready for winter

Extreme cold and sharp changes in temperature can affect your vehicle's performance if it is not maintained properly. Extra precautions should be taken to keep your vehicle running perfectly at all times.

Your vehicle requires certain special equipment in winter (such as a snow shovel and booster cables) and some of its components have to be adjusted for the season (such as tires, windshield wipers and lubricants). Although the vehicle's owner is the one primarily responsible for preparing it for winter, make sure it is safe and ready for the season before taking it out on the road for the sake of your own safety and that of others.

# DRIVING IN DIFFICULT CONDITIONS

## Driving at night

Although many professional drivers are used to driving at night, this is still a very difficult and demanding task. You need to pay extra close attention to the road. As we have already noted, driving at night is a factor that contributes to problems of fatigue.

At night, for the sake of your safety, it is strongly recommended that you drive more slowly than the speed limit. The faster you drive, the narrower your field of vision. If an unexpected hazard arises, your reduced field of vision can have a major impact on how long it takes you to perceive what is happening, make a decision and react. Make sure your stopping distance is within the range of your headlights.

For example, with your low beams, you can see up to about 75 m ahead of your vehicle and with your high beams you can see up to 150 m ahead. If you are moving too fast, you do not have enough time to avoid any obstacles beyond this range.

In addition to reducing visibility, night driving reduces your visual acuity and your ability to make out contrasts, discriminate between colours and perceive depth. Objects are hard to see because they blend in with the darkness, so it is hard to evaluate distance and speed at night. To make up for this, it is important to reduce your speed. As well as slowing down, you should look beyond the area covered by your headlights so that you can detect the presence of a pedestrian or an obstacle with enough time to react.

Glare is a major problem when driving at night. Glare from lights can impair your vision for several seconds at a time. This means that you can cover a fair distance before your eyes completely readjust to the dark. Be extra cautious when meeting oncoming vehicles. Also, make sure you never wear glasses that are even slightly tinted at night because they reduce visibility.

#### HOW TO AVOID GLARE WHEN DRIVING AT NIGHT

- ▶ Limit the sources of light from your dashboard and adjust them as low as possible because they can cause distraction and fatigue.
- ▶ Avoid looking directly at the headlights of other vehicles. Instead, you should look towards the right side of the road when you meet another vehicle.
- ▶ If you are being blinded by glare from the headlights of oncoming vehicles, slow down. After being blinded by headlight glare, your eyes need time to become accustomed to the dark again before you resume your speed.
- ▶ Flip your headlights back on high beams immediately after passing an oncoming vehicle, because this is when you need the strongest light.
- ▶ If other drivers keep their high beams on and they are blinding you, click your own high beams on then off again. If the driver still does not switch to low beams, do not insist. Slow down, stay as close to the right side of the lane as possible and look off to the right side of the road. If you need to, pull over onto the shoulder and stop for a few minutes.



At night, being seen by others is just as important as being able to see. Make sure your vehicle's lights are clean and in good working order.

Also, it is important to keep your mirrors and windshield clean, both inside and out. This way, your field of vision will be unrestricted and any negative effects from lights will be kept to a minimum. This is even more important in bad weather.



## Rain or shine

Driving can be dangerous even when the weather is fine. You can be lulled into a false sense of security and let down your guard. Blinding sunlight, for example, can become a major hazard, so be careful!



When it begins to rain and the water on the road surface mixes with dust, sand, oil and other fluids from vehicles, the pavement becomes slippery. Slow down so that you will not have to steer or brake abruptly.

At dawn and dusk, in rain, snow or fog, it is hard to see other vehicles and hard for them to see you. Turn on your headlights to be sure you are visible to other road users. Your parking and tail lights are not sufficient for others to see you clearly.

If your field of vision is reduced by snow or freezing rain on the windshield, turn on your windshield wipers and, if necessary, pull over somewhere where you can clean your windshield, windows and rear view mirrors and clear the ice or snow off your wipers.

In these kinds of conditions, when the road is snow-covered or slippery or when visibility is reduced, braking and steering are much more difficult. You must slow down. If visibility is nil, pull over somewhere safe as soon as possible to avoid colliding with other vehicles or going off the road.

Driving in winter poses special challenges, such as icy patches or black ice. Winter conditions often mean less traction. **Slow down!** Loss of traction affects your vehicle's acceleration, braking and handling.

Car drivers sometimes tend to follow too close behind heavy vehicles. They are usually not aware that the heavy vehicle driver they are following is unable to see them. So be especially careful when braking.

### BRIDGES AND OVERPASSES

It is important to remember that road surfaces on bridges and overpasses can become especially slippery and dangerous when the temperature falls to near the freezing point. Because of condensation, an invisible sheet of ice, referred to as "black ice", may form on the roadway.



# SELF-EVALUATION EXERCISES

## Theoretical Exercises



### TEST YOUR KNOWLEDGE OF FATIGUE

## Multiple-Choice Questions

---

- 1. What are the principal causes of accidents on Québec roads?**
  - a) Speeding and distraction.
  - b) Alcohol and drugs.
  - c) Speeding, alcohol, distraction and fatigue.
- 2. If you are tired or are experiencing fatigue while driving, you should:**
  - a) pull over and stop in a safe location to rest.
  - b) turn up the volume of the radio.
  - c) open the window to let in some fresh air.
- 3. In preparation for a long trip:**
  - a) make sure that you get a good night's sleep before leaving and allow time for rest stops and naps when planning your route.
  - b) leave in the evening and drive at night to avoid traffic.
  - c) try to drive for as long as possible while you are feeling alert in order to get to your destination as soon as possible.
- 4. The effects of fatigue on driving are similar to those of a blood alcohol concentration of 0.05 after:**
  - a) 10 hours without sleep.
  - b) 14 hours without sleep.
  - c) 17 hours without sleep.



- 5. If you are already tired, how do you think drinking one or two glasses of alcohol will affect your ability to drive?**
- a) Not at all.
  - b) Slightly.
  - c) Significantly.
- 6. Periods of drowsiness while at the wheel are:**
- a) more frequent at night.
  - b) more frequent during the day.
  - c) just as frequent during the day as at night.
- 7. Most people require seven to nine hours of sleep each night. If you get less than a full night's sleep, it causes a sleep debt. Your ability to drive begins to be affected after:**
- a) a single night without a full night's sleep;
  - b) two nights without a full night's sleep;
  - c) no particular number of nights, because missing sleep has no effect on driving.
- 8. In your opinion, during what period of the day is there the lowest risk of fatigue-related accidents?**
- a) in the morning between 8:00 a.m. and noon.
  - b) in the afternoon between 1:00 p.m. and 3:00 p.m.
  - c) at night between midnight and 6:00 a.m.
- 9. To perform most efficiently, a driver under age 25 should sleep:**
- a) the same number of hours as an older driver.
  - b) fewer hours than an older driver.
  - c) more hours than an older driver.

10. If you begin to experience fatigue while driving, you:
- are unaware of the first signs of fatigue.
  - are aware of the signs of fatigue, but ignore them.
  - pull over and rest.

## True or false

---

11. Indicate whether the following statements are true or false.

	True	False
1. When driving at night, you must make sure that the distance you need to come to a full stop is within the area lit by your headlights.	<input type="checkbox"/>	<input type="checkbox"/>
2. The only one responsible for complying with vehicle size and load limits is the operator.	<input type="checkbox"/>	<input type="checkbox"/>
3. Using your parking and tail lights to signal your presence to other road users is sufficient when visibility is reduced.	<input type="checkbox"/>	<input type="checkbox"/>
4. It is a good idea to check the condition of your tires more frequently in very hot weather.	<input type="checkbox"/>	<input type="checkbox"/>

Answers at the end of the guide.

# KNOW YOUR VEHICLE

3

---

Each vehicle has its own special features, but the controls and dashboard indicators that allow you to drive, control your speed, steer your vehicle and keep it on course are similar from one vehicle to another.

As a professional driver, it is your responsibility to familiarize yourself with the vehicle you drive. If you do not, you may run into serious problems.

Chapter 3 explains how heavy vehicle controls work. Consult the manufacturer's manual for information specific to the vehicle you are driving.

# TYPES OF HEAVY VEHICLES

The types of heavy vehicles on the road network are as varied as uses for which they are designed.

## Various configurations

### Straight-body truck



### Tractor semi-trailer



### Truck-trailer



## Double road train



## City bus



## School bus



## Motor coach (intercity bus)



# DASHBOARD INDICATORS

## 3

While operating your vehicle, you must constantly monitor its performance. You need to be familiar with all the dashboard indicators, buttons and levers so that you can drive as safely and as efficiently as possible.



These devices allow you to constantly monitor the status of your vehicle's various systems and mechanisms. This is why professional drivers must remain vigilant and regularly check their vehicle's gauges and indicators so that they will be immediately informed of any defect or malfunction that could pose a hazard.

There are as many different types of dashboards as there are types of heavy vehicles. Before setting out on the road, make sure you can easily locate all the indicators and know how to operate all the buttons and levers.

Every component of the dashboard is there for a reason, but some are more important than others and need to be checked or used more frequently:

- ▶ Controls:
  - ▷ trailer air supply
  - ▷ windshield wiper/washer
  - ▷ semi-trailer hand brake
  - ▷ parking brake
  - ▷ gear shift

- ▶ Indicators:
  - ▷ fuel gauge
  - ▷ coolant temperature gauge
  - ▷ speedometer
  - ▷ low pressure gauge
- ▶ Engine oil pressure gauge
- ▶ Primary and secondary circuit air pressure gauge
- ▶ Exhaust heat gauge
- ▶ Tachometer
- ▶ Voltmeter

# STEERING WHEEL

## Hand position

Driving a heavy vehicle requires special skills. Because they are so much bigger than most other vehicles on the road, it is especially important for you to operate your vehicle expertly and safely.

The main thing to remember is this: hold the steering wheel with both hands and vary your position while driving so that you can sit comfortably. Be sure also to grip the steering wheel with your hands positioned far enough apart on the wheel so that you can maintain firm steering control and react quickly no matter what happens.

Some models of heavy vehicles require the use of a special technique for making turns due to the size or configuration of the steering wheel they are equipped with. You must sit well back in your seat and keep your arms bent when turning the wheel. An easy way to achieve this is to start turning the wheel with your hands at the 8 o'clock/4 o'clock position. To turn right, for example, move your right hand from 4 o'clock to 6 o'clock. Then grip the wheel at 6 o'clock with your left hand and move it to 8 o'clock, while your right hand returns to 4 o'clock. Continue in this way until the vehicle's wheels are turned in the right direction.



# ACCELERATOR

# 3

The accelerator allows the driver to control vehicle speed. To set the vehicle in motion, you have to accelerate smoothly and gradually to avoid causing the vehicle to jerk. The sole of your shoe should lie flat against the accelerator pedal with your heel on the floor.

The way to obtain optimal engine performance is to see that just the right amount of fuel is flowing to the engine. Although injection systems are equipped with ever more efficient flow regulation devices, the accelerator still plays a role. You should accelerate gradually while gauging engine RPM. Once you reach your desired speed, maintain that speed: this will help to maintain control over your vehicle.

# TYPES OF TRANSMISSIONS

## Automatic transmission

Many vehicles have transmissions that change gears automatically in response to speed and acceleration by means of mechanical, electrical or hydraulic controls. Gear positions vary from one automatic transmission to the next.

Note that, in contrast to automatic car transmissions, automatic transmissions in heavy vehicles do not have a PARK setting. To make sure the vehicle remains stationary when you are stopped, shift into neutral (*N*) while the engine is still running and apply the parking brake.

Another important point to note is that, when braking or downshifting in 1st and 2nd gears, the drive wheels can block on a slippery roadway and cause you to lose control of your vehicle.

## Mechanical gear shift

This model of gear shift is similar to the type usually installed in automobiles with a gear-shift lever. The gear positions are used as follows:

- ▶ **N (neutral)**  
For starting the engine, for idling for an extended length of time and for parking.
- ▶ **R (reverse)**  
For backing up (bring the vehicle to a full stop before using this gear).
- ▶ **2 to 5 or D**  
Forward gears to be used for normal driving conditions.
- ▶ **2 and 3 or 2 to 4**  
Lower gears for driving with loads.
- ▶ **2**  
The gear usually used for driving in snow or on a steep grade.
- ▶ **1**  
The gear that gives you the maximum vehicle power. It is used for driving very slowly under off-road conditions (bumpy or unpaved roads).
- ▶ **MODE**  
The button generally used to activate a program for using the transmission in Performance or Economy mode.

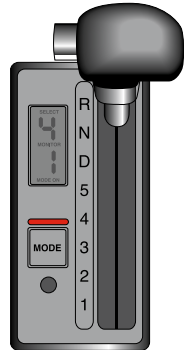

## Electronic and electromechanical gear shift

Electronic and electromechanical gear shifts are operated by means of buttons rather than a lever.

This type of gear shift has the same positions as a mechanical gear shift, but also two additional buttons: ↑ (up) and ↓ (down). These buttons allow you to manually select a gear that is higher or lower than the gear automatically selected. In this way, you can select any gear (1 to 5) depending on road conditions, as explained in the previous section on mechanical gear shifts.

Before selecting a gear, you must first press the MODE button to switch from automatic to manual.

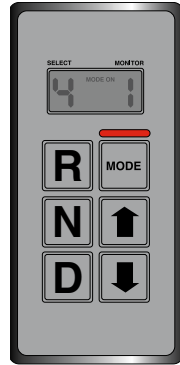

## Automated manual transmission

More and more heavy vehicles are equipped with automated manual transmissions. This type of transmission constantly monitors various factors that have an impact on gear shifting, such as changes in road grade, vehicle weight and speed, and rolling resistance. Because it is a “smart” transmission, it can analyze all these factors to determine when engine parameters are just right for the smoothest transition from one gear to another.



## Manual transmissions

# 3

There are two types of manual transmissions found on heavy vehicles: synchromesh and non-synchromesh. Manual transmissions (and certain automated manual transmissions) are equipped with a clutch pedal.

### Using the clutch pedal

The clutch pedal controls the clutch, which couples the engine to the transmission and transmits power to the drive wheels. When the pedal is raised in normal driving position, the clutch is engaged and power is transmitted to the wheels. When you press down on the clutch pedal, the clutch is disengaged, the engine is uncoupled from the transmission and power is no longer transmitted to the wheels, which is the equivalent of shifting into neutral. Only then can you shift gears with a manual transmission.

Your driving position is crucial for proper clutching. You must be seated in such a way that you can press the pedal down far enough to disengage the clutch completely, while maintaining your knee slightly bent.

When driving your heavy vehicle, you must avoid:

- ▶ forcing the transmission by releasing the clutch pedal too quickly;
- ▶ allowing the transmission to slip by releasing the pedal too slowly because such friction could generate excess heat and prematurely wear out the clutch plate;
- ▶ resting your foot on the clutch pedal when not using it (this may cause needless wear on the clutch);
- ▶ pushing the clutch pedal all the way to the floor when shifting gears.

## Synchromesh manual transmission

A synchromesh manual transmission usually has 5 or 6 gears. A synchromesh inside the gear box enables you to shift gears without grinding. This type of transmission is used primarily on school buses and certain double-axle trucks with a low gross vehicle weight rating. Using this type of transmission requires a clutch pedal similar to that of passenger vehicles and does not require you to use the double-clutching technique.

## Non-synchromesh manual transmission

A non-synchromesh manual transmission is used primarily in heavy vehicles having three or more axles and a high gross vehicle weight rating (including tractor semi-trailers). It usually has 8 to 18 gears.

Because it is not equipped with a synchromesh enabling you to shift gears without grinding, you must use the double-clutching technique for safe and efficient driving. Mastering this technique requires a good sense of timing and many hours of practice.

### Using a non-synchromesh manual transmission

To use a non-synchromesh manual transmission, you must be familiar with the principal features of your vehicle's engine, clutch pedal and transmission.

## Engine

The principal characteristics of your engine you need to know are the number of revolutions per minute (RPM) when it is at idling speed and at top speed and its maximum torque. You must check your engine's RPM each time you shift gears. You must be able to quickly refer to the tachometer on your dashboard when shifting gears.

### Four-position clutch pedal

The clutch pedal in a non-synchronesh manual transmission has four positions, each of which plays a specific role. In order to apply the double-clutching technique properly and efficiently, you must understand how each of these four positions is used:



- 1. Upper free play**

Prevents certain components from constantly spinning, which creates unwanted friction.

- 2. Friction point**

Uncouples the engine from the transmission before you change gears.

- 3. Lower free play**

Makes the transition from the friction point to the clutch brake.

- 4. Clutch brake**

Stops the motion of certain components of the transmission so that you can shift into 1st gear.

## Transmission

The transmission multiplies engine power and transmits it to the differential. The vast majority of non-synchromesh manual transmissions are configured in one of the following two ways:

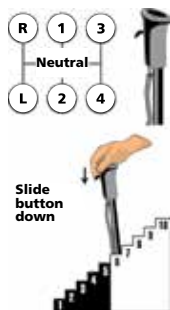

10- and 15-gear transmissions generally follow this model.

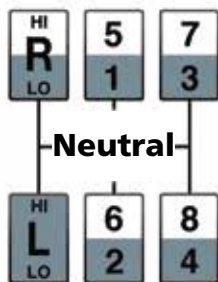

8-, 13- and 18-gear transmissions usually follow the layout shown above.

- ▶ 10 or 15 gears, with an increment of approximately 300 RPM from one gear to the next on flat terrain.
- ▶ 8, 13 or 18 gears, with an increment of approximately 400 RPM from one gear to the next on flat terrain.

## Double-clutching technique

To use the double-clutching technique, you have to understand how to upshift and downshift.

The examples used in this section assume you are driving a vehicle equipped with a **10-gear transmission** and an engine functioning as follows:

- ▶ idling speed: 650 RPM;
- ▶ top speed: 1,800 RPM;
- ▶ maximum torque: 1,200 RPM.



For shifting gears efficiently, the right RPM is:

1. 650 RPM for 1st gear;
2. 950 RPM for 2nd gear;
3. 1,250 RPM for 3rd gear;
4. 1,550 RPM for 4th gear.



#### Upshifting into 1st gear:

1. Press the clutch pedal down to the lower free play (position 3), or to the clutch brake (position 4) if there is grinding as you are shifting into 1st gear.
2. Then slowly release the clutch pedal up to the friction point (position 2) until the vehicle starts moving.
3. Gradually press down on the accelerator while also gradually releasing the clutch pedal.

#### Upshifting into 2nd gear:

Based on the parameters in the example given above, to shift into 2nd gear, you would need to reach an engine speed of about 300 RPM higher than idling speed, so the ideal moment for shifting gears would be when the engine's speed reaches 950 RPM. However, when you are on the point of shifting, it is difficult to do so if the difference between the actual RPM at that moment and the RPM necessary for the manoeuvre (according to the number of gears of the transmission) is lower than the RPM at idling speed (for example, 800 RPM – 300 RPM = 500 RPM).

So, to upshift into 2nd gear, you must:

1. Press down on the accelerator until the engine reaches 950 RPM.
2. Press down on the clutch pedal to the friction point (position 2), and then continue pressing the clutch pedal down to the lower free play (position 3) as you release the accelerator.
3. Shift into neutral (N).
4. Release the clutch pedal up to the upper free play (position 1) to reach an engine speed of 650 RPM.
5. Press the clutch pedal down again to the lower free play (position 3) and shift into 2nd gear.
6. Gradually press down on the accelerator as you release the clutch pedal.

Use the same technique to shift into higher gears.

Important: To shift into higher gears, you have to increase engine speed to 1,500 RPM in order to maintain an optimum torque of 1,200 RPM after subtracting the 300 RPM necessary to perform the manoeuvre (for example,  $1,500 \text{ RPM} - 300 \text{ RPM} = 1,200 \text{ RPM}$ ).

## Downshifting

When downshifting, you must use the double-declutching technique to prevent friction between the components of the non-synchromesh manual transmission and to guard against its mechanism wearing out prematurely. Double-declutching, like double-clutching, requires you to shift into neutral, but you must increase engine speed before downshifting.

## Downshifting technique

To downshift, you must slow down your vehicle with the service brake in order to reduce the engine's speed and stabilize its RPM. The engine's speed must be reduced to no faster than its maximum RPM when in neutral.

For example, based on the parameters in the example given above, you would downshift from 5th to 4th gear using the following procedure:

1. Slow your vehicle down until the gauge reads 1,200 RPM and push the clutch pedal down to the friction point (position 2).
2. Make sure your engine speed (RPM) is still the same, then push the clutch pedal down to the lower free play (position 3) as you release the accelerator.
3. Shift into neutral (N).
4. Release the clutch pedal up to the upper free play (position 1).
5. Push down on the accelerator to increase engine speed by 300 RPM until you reach 1,500 RPM (1,200 RPM + 300 RPM).
6. Release the accelerator as you push the clutch pedal down to the lower free play (position 3) and shift into 4th gear.
7. To complete your downshifting manoeuvre, release the clutch pedal.

The technique for downshifting into lower gears is the same. Mastering the double-clutching technique requires a great deal of time and you should practise it on flat terrain.

# THE RIGHT RPM IS IMPORTANT FOR YOUR ENGINE

An engine that does not turn over fast enough tends to lurch and this can damage your vehicle. An engine that turns over too fast, on the other hand, consumes fuel needlessly and provides no more power than it would at a lower RPM.

You should consult the manufacturer's manual for information on your engine's requirements and the recommended RPM ranges for changing gears.

All engines have a top RPM. It is a good idea to change gears before the engine reaches that limit—a method also known as progressive shifting—if only to save on fuel. Referring to the tachometer is a more reliable way of determining when to change gears than listening to the sound of the engine or checking your speed.

### PROGRESSIVE SHIFTING

When less efficient engines were still being used, drivers needed to rev their engine to maximum RPM before changing gears. Professional drivers are now moving away from this method and using progressive shifting, which is better suited for modern engines.

With progressive shifting, you bring the engine speed almost up to minimum torque when shifting into the first 3 or 4 gears. For shifting through all higher gears, you need to increase RPM so that the engine turns over almost at or slightly above minimum torque. The advantage of progressive shifting is that it takes less time to get into the next gear and you can reach cruising speed more quickly.

Since frequent gear changes mean higher fuel consumption, progressive shifting translates into undeniable savings when used for all types of transport. Both for long-haul transport and for urban transport with multiple stops, this method allows you to save on fuel because your engine remains at a moderate RPM and you reach cruising speed faster.

### Limiting speed = fuel savings

You can make the biggest fuel savings when driving on highways. We recommend that you stay at 90 km/h or under in order to minimize wear on the engine, tires and brakes, as well as saving on fuel. When driving a tractor semi-trailer combination, if you reduce your cruising speed from 105 km/h to 90 km/h, you reduce your fuel consumption by an average of 10%. And the extra driving time this adds to your trip is not as great as you might think.

Today's vehicles are more economical and run more efficiently than older models, providing you use the proper techniques for operating them.

## Brakes

Brake systems are comprised of mechanical components that are operated primarily by hydraulic (fluid) or compressed air pressure.

But all heavy vehicle brake systems, regardless of their type, include the following components:

- ▶ the service brake, which allows you to reduce the speed of your vehicle (or vehicle combination) using the brake pedal;
- ▶ the parking brake, which keeps your vehicle stationary when it is parked;
- ▶ the emergency brake, which allows you to stop your vehicle if the service brake is not working properly or in the event of a trailer breakaway.

We will now take a quick look at hydraulic brake systems because many vehicles still have this kind of brake. The next chapter will deal at greater length with the most widespread brake system for heavy vehicles such as tractors, semi-trailers, buses and trucks: air brakes.

## Hydraulic brake controls and indicators

### Brake pedal

The brake pedal allows you to operate the service brake system in order to slow down or stop your vehicle. When the brake pedal is abnormally low, this is a serious warning signal. If this happens to you, you can increase braking pressure slightly by pumping rapidly and repeatedly on the pedal, but make sure you have your brakes repaired right away.

Vehicles are equipped with a dual circuit brake system. Because of the dual circuit brake system, you can still brake even if one of the hydraulic circuits is defective, but you have to press the pedal harder, since the brakes are applied on only some of the wheels. For this same reason, braking distance may be longer and you must have the brakes repaired before using the vehicle again.

## Power brakes

With power brakes, you do not have to push very hard on the brake pedal. However, if the engine shuts down and the vehicle stalls, you have to apply greater pressure on the pedal. This is why you are prohibited from driving if your power brake system is not working properly.

## Service brake pressure light

As soon as you start your engine, this light comes on to indicate that the hydraulic system is operating properly. If the light stays on, however, this could mean that the hydraulic system is defective.



## Parking brake light

This light indicates that the parking brake is on.



# SELF-EVALUATION EXERCISES



## Theoretical Exercises

### True or false

---

1. Indicate whether the following statements are true or false.

	True	False
1. For driving in snow or on a steep grade with an automatic transmission, you should shift to 2nd gear.	<input type="checkbox"/>	<input type="checkbox"/>
2. Using the double-clutching technique does not require you to understand how to upshift and downshift.	<input type="checkbox"/>	<input type="checkbox"/>
3. The tachometer is a more reliable indicator of when to change gears than the sound of the engine.	<input type="checkbox"/>	<input type="checkbox"/>
4. The progressive shifting method consists of revving the engine to maximum RPM before changing gears.	<input type="checkbox"/>	<input type="checkbox"/>
5. The emergency brake is used to hold the vehicle stationary when it is parked.	<input type="checkbox"/>	<input type="checkbox"/>

Answers at the end of the guide.



# PNEUMATIC (AIR) BRAKE SYSTEMS

4

---

In this chapter, we will be dealing with full air brake systems only. Also, we will describe only the type of modern multi-circuit air brake system that is connected to all the vehicle's wheels. You should note, however, that even though they operate on the same principles, brake systems vary slightly from one manufacturer to another and depending on the vehicle's intended use.

All brake systems include service brakes, parking brakes and emergency brakes. If you are familiar with the basics of how brake systems work, you will have a better chance of obtaining the maximum braking power in all situations. You should check your brakes frequently and know how to operate them properly.

# THE MOST POPULAR BRAKE SYSTEM

Air brakes have become increasingly popular as heavy vehicles have increased in size and load capacity.

Today, almost all heavy vehicles are equipped with air brakes. Air brake systems have changed and improved over the years, however. They offer many advantages:

- ▶ They are usually more powerful than hydraulic systems.
- ▶ They have proven their reliability.
- ▶ It is easy to connect other vehicles and other air-powered equipment to them. For example, compressed air is now used for the suspension and certain other equipment.

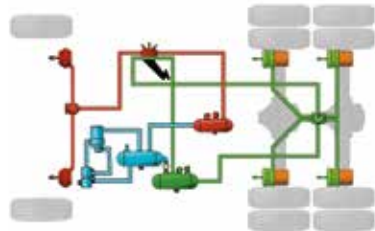
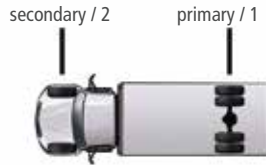

Air brake systems are basically made up of a compressed air supply circuit and two circuits, the primary circuit (P or 1) and the secondary circuit (S or 2), that make it possible to activate the service brakes on all of the vehicle's wheels. The primary and secondary circuits may be installed differently from one vehicle to another. They work independently, so that if one of them fails, the other one continues to operate normally.

# CONTROLS AND COMPONENTS

## Driver's cab

### Brake pedal

This pedal is used to activate the service brakes on all of the vehicle's wheels, including the wheels of the trailer or semi-trailer. By pressing down on the brake pedal, you allow the compressed air in the service reservoirs to flow into the brake chambers.

The more pressure you apply to the pedal, the greater the amount of air that enters the brake chambers. However, the amount of pressure required may vary from one vehicle to another and is affected by the vehicle's load. With practice and experience, you will find out just how much pressure you have to apply to slow your vehicle down or bring it to a stop with no risk of causing the wheels to lock up.

### Semi-trailer hand brake control

This hand brake control is used to apply the service brakes, but only on the semi-trailer's wheels. By pulling up on this lever (or pushing down on it, on some models), you send compressed air from the service reservoirs to the brake chambers of the semi-trailer's wheels.



The hand brake is either attached to the steering column or installed on the dashboard. It is sometimes used by drivers to check whether the semi-trailer is properly hitched. After completing the hitching operation, it can also be used to check whether the service brakes for the trailer or semi-trailer are working properly.

The hand brake should never be used as a parking brake or, when on the road, as a service brake. Using the hand brake as a service brake while on the road is definitely a less effective way of slowing your vehicle than using the service brake for the vehicle combination activated by the brake pedal. If you use the hand brake as a service brake, the braking effect will not be equally distributed over all the wheels in the vehicle combination: the brakes on the semi-trailer will produce much more heat and could even overheat, rendering them less effective. Also, using the hand brake as a service brake could cause the vehicle to skid on icy surfaces.

## Parking brake control

The parking brake control is the yellow diamond-shaped knob located on the dashboard. When you pull up on it, air is released from the vehicle's brake chambers. Once the chambers are empty, powerful springs are activated and the wheels that are equipped with a parking brake are clamped into place.



The parking brake control is used to hold your vehicle stationary. You must pull up on the knob before getting out of the cab. In the case of tractor semi-trailers, this control allows you to apply the parking brakes on both the tractor and the semi-trailer.

Before you start driving your vehicle, you need to push down on the parking brake control in order to release the parking brakes. This allows the compressed air in the reservoirs to fill the brake chambers so that the springs are compressed and the wheels unclamped.

## Trailer air supply control

Your service brakes will not work properly unless the compressed air reservoirs are adequately filled.

To send air to the trailer or the semi-trailer service reservoirs, you must use the octagonal-shaped red knob located on the dashboard. This knob (as well as the parking brake knob) is always the same colour and shape in all vehicles. Pushing down on the knob activates a valve that allows compressed air to flow to the trailer or semi-trailer brakes.



The trailer air supply control is also used to apply or release the parking brake of the trailer or semi-trailer. Pulling up on the knob closes the air-flow valve. This releases air from the brake chambers of the trailer or semi-trailer so the parking brake can be applied to all the corresponding wheels. Among other things, this enables you to immobilize a trailer or semi-trailer before unhitching it.

## Air pressure gauge

The air pressure gauge measures the air pressure in the service reservoirs of a bus, truck



or tractor. Since the service brake system has two independent circuits (see p. 91), there are two air pressure gauges on your dashboard, one for each circuit. There may also be only one air pressure gauge, but with two needles, one for each circuit, but there is no gauge for the supply reservoir.

## Low air pressure indicator

If the air pressure drops so low in one of the circuits that the service brakes are unable to work effectively, a visual warning device is activated to alert the driver, sometimes accompanied by a buzzer. There are two types of visual warning devices: a warning light and a wigwag.



The level at which the low air pressure indicator is activated varies depending on the vehicle's brake system, but is never lower than 380 kPa (55 psi). When the air pressure drops to 380 kPa (55 psi), it is too low to deactivate the parking brake (if it is on), but there is still enough pressure for the vehicle to keep moving if it is already in motion.

## Service brake pressure gauge

This gauge measures the compressed air pressure in the brake chambers when the brakes are applied.



Unlike the air pressure gauge, the service brake pressure gauge is not a standard feature in heavy vehicles.

## Other parts of the vehicle

### Compressed air reservoirs

Compressed air is sent through the lines and stored in reservoirs. The compressed air provides the power required to activate the service brake and release the parking brake. When you press the brake pedal, the service brake exerts pressure on each of the vehicle's wheels.

Heavy vehicles have at least three compressed air reservoirs. The first one, referred to as the "supply reservoir," receives air directly from a compressor and sends it on to the other two reservoirs. These other reservoirs, referred to as "service reservoirs," supply air to the brake chambers near the wheels.

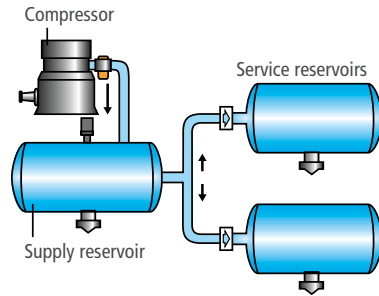

Trailers and semi-trailers have their own compressed air reservoirs that are supplied by the service reservoirs of the truck or tractor.



The reservoirs store enough air to make the brakes work. If the compressor fails, the service brakes will still work for a while. However, depending on how you use your brakes, how much air is used by accessories and other components, and how air-tight the system is, the compressed air supply may run out very quickly. If this happens, you will be warned of the seriousness of the situation by the low air pressure indicator and the emergency brake will be activated. As soon as you see the warning signal, you should pull over and have the necessary repairs done.



Some vehicles, buses for example, are equipped with an additional compressed air reservoir that is useful in an emergency. If the service brakes fail and the emergency brakes are activated, the additional air supplied by this reservoir can be used to immediately move the vehicle just a few metres farther on from the point where it came to a stop.



## Emptying reservoirs

It is essential for the air to be clean if the brake system is to perform well. Impurities can build up inside the reservoirs because of changes in temperature and environmental conditions. To eliminate them, the reservoirs need to be emptied completely, or “bled,” every day. You do this by fully opening the air bleed valve that is provided with each reservoir. In winter, you should bleed the reservoirs after operating your vehicle while it is still warm to avoid the risk of the valves freezing up and remaining stuck in the open position.

Most heavy vehicles nowadays are equipped with an air purifier (also referred to as an “air dryer” or “air filter”). The air purifier is located between the air compressor and the supply reservoir. It filters and dries the air and eliminates impurities. You must still bleed the reservoirs, even if your vehicle is equipped with such a device.

## Air compressor and pressure regulator

The air compressor draws in and stores air from the outside, compresses its volume and then sends the compressed air into the supply reservoir.

The compressor is driven by the vehicle’s engine, so it operates only when required and when the engine is running. Some systems operate at different pressure

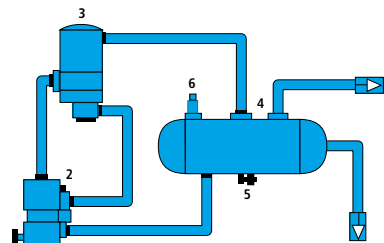

- |                       |                     |
|-----------------------|---------------------|
| 1. Air compressor     | 4. Supply reservoir |
| 2. Pressure regulator | 5. Air bleed valve  |
| 3. Air purifier       | 6. Protection valve |

levels, but they always maintain a spread of 138 kPa (20 psi). For example, the air compressor generally begins operating when the air pressure in the service reservoirs drops below 724 kPa (105 psi). It stops filling the reservoirs when the pressure reaches 862 kPa (125 psi). Most air brake systems function within these limits.

The pressure regulator manages the operation of the air compressor by maintaining the pressure in the service reservoirs. The pressure regulator starts the air compressor before the air pressure in the reservoirs drops to 550 kPa (80 psi) and stops it when air pressure rises to between 805 kPa (117 psi) and 945 kPa (137 psi). Refer to Chapter 12 on vehicle inspection for information on malfunctions affecting the pressure regulator.

The truck's or the tractor's compressor also fills the reservoirs of the trailers or semi-trailers via the service reservoirs of the tractor vehicle.

## Brake chambers

There is a brake chamber near each of the vehicle's wheels. When you activate the service brakes, air flows through the lines from the service reservoirs to these chambers. When the air enters the chamber, it pushes on a membrane—the diaphragm—that is attached to a push rod. In the case of a drum brake, for example, when the push rod moves, it operates a slack adjuster that drives a camshaft. The movement of the S-cam makes the brakes clamp.

There are two kinds of brake chambers. The first is a single chamber (service brake), and the second is a double chamber (service brake and parking brake).

## Single brake chamber

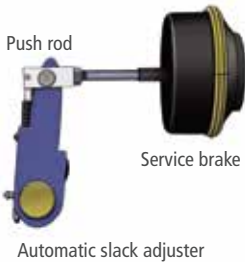

A service brake is installed on each of the wheels. When you apply the brake pedal, it allows the air in the service reservoirs to flow into the brake chambers and activate the service brake. Unlike a hydraulic brake system, in an air brake system braking power is supplied by the pressure exerted by compressed air, rather than by your own muscle strength.

## Double brake chamber

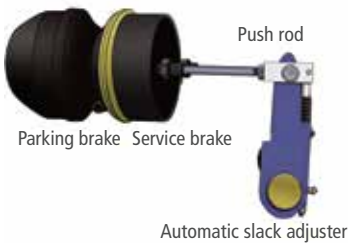

As for parking brakes, they are mounted only on the rear wheels of the tractor, truck or bus (these vehicles must be equipped with double brake chambers on at least one axle). Parking brakes are also found on the trailer or semi-trailer wheels (except for the wheels on most auxiliary lift axles). A parking brake is thus always paired with a service brake.

The parking brake is equipped with a powerful spring that allows the brake to be applied mechanically when the vehicle is parked and that also activates the emergency brake if a problem arises. When you pull up on the parking brake lever, this empties the air from the parking brake part of the double brake chamber. The springs relax and this activates the parking brake. When you push down on the parking brake lever, just the opposite happens: air flows into the parking brake part of the double brake chamber, compresses the springs and disengages the wheels, which are then free to turn.

## Drum brakes

A drum brake system is made up of brake shoes equipped with linings that press on the inside surface of a drum mounted on the wheel. When you press the brake pedal, two brake shoes covered with linings press against the drum and this pressure causes the vehicle to slow down or stop.

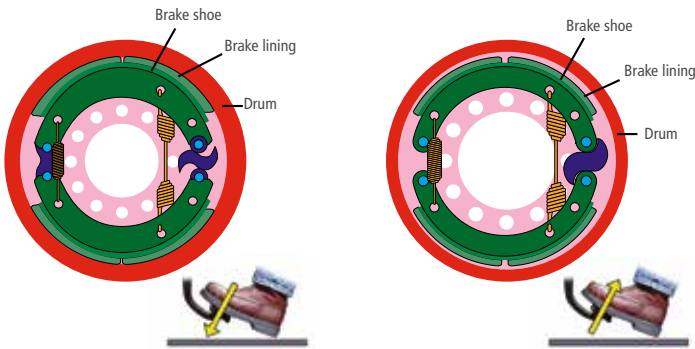
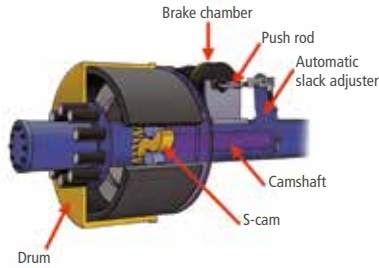

Drum brakes—more specifically S-cam brakes—are the most common kind of brake found on heavy vehicles. The name is derived from the fact that an S-shaped cam is used to pull the brake shoes apart.

When you apply the brakes and when the slack adjuster is properly adjusted, the friction of the brake linings against the drum produces a great deal of heat. Brake linings lose their effectiveness if they become overheated through misuse or overuse. Refer to Chapters 5 and 6 to find out about certain techniques you can use to slow your vehicle without compromising the efficiency of the brake linings and without overheating them.

## Disc brakes

A disc brake is made up of a disc installed on the hub and brake linings (or “pads”) that are held in place by a caliper attached to the vehicle and that rub against the disc on both sides. When you press down on the brake pedal, the caliper pushes the brake pads against the disc and slows the vehicle or brings it to a stop.

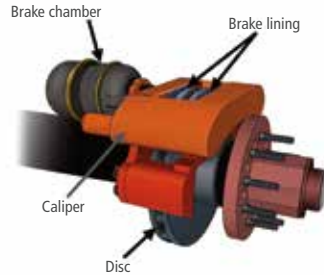

Disc brakes are the most frequently used type of brakes in motor coaches and are being used more and more in other types of heavy vehicles. In contrast to drum brakes, disc brakes consume less air (because the brake chamber is smaller) and their braking efficiency is less likely to be impaired at high temperatures.

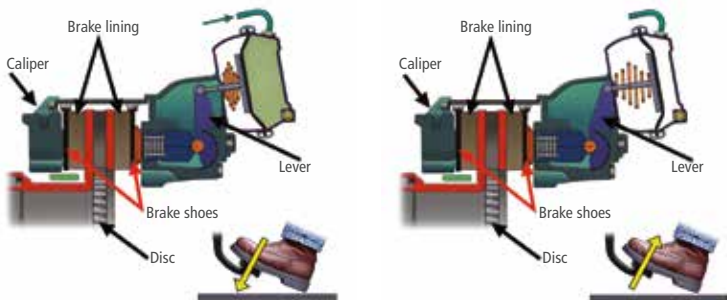

## Trailer brake hoses

Brake hoses are tubes that allow compressed air to flow between adjacent vehicles and supply the brake lines of the trailer or semi-trailer. In general, red brake hoses are used to supply air to the brake chambers for the service brakes (via the service reservoir) and to release the parking brake, and blue brake hoses are used to supply air to activate the relay valve of the trailer or semi-trailer, which allows air to flow into the brake chambers of the service brakes.



Each trailer brake hose ends with a brake hose coupler. When two or more vehicles are hitched together, each vehicle has two brake hose couplers. It is important to connect corresponding couplers (of the same colour) to each other. For example, when hitching a tractor to a semi-trailer, you must hook up the hose coupler for the tractor service brake circuit with the coupler for the semi-trailer service brake circuit. The same rule applies when connecting hose couplers for the trailer or semi-trailer parking (or emergency) brake circuits.

To connect brake hose couplers, you must fit them together at a 90° angle and then rotate them until the hoses are lined up straight.

If your road tractor is not hitched to a semi-trailer or trailer, you must hook up each brake hose coupler to a dummy brake hose coupler.

If your vehicle has brake hoses but no dummy couplers, you can attach the hose couplers side by side and secure them properly to the vehicle to prevent the hoses from falling to the ground and to keep dirt from entering the system.

# HOW SERVICE BRAKES WORK

Service brakes allow you to slow down or stop your vehicle when you are driving under normal conditions. Braking is made possible by complex networks of lines through which air circulates.

## Compressed air

The service brake system enables you to stop your vehicle by using various mechanisms to amplify the force you apply on the brake pedal. Even a slight pressure on the brake pedal can result in a great deal of pressure on each vehicle wheel to stop it from turning.

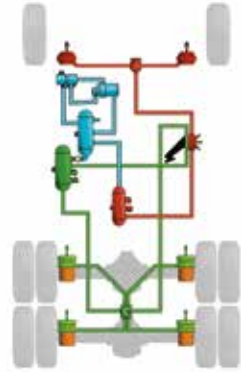

Air circulates through the system. The compressor draws in air from outside the vehicle and sends it through an air dryer and then into the supply reservoir. From there, the air flows to the service reservoirs. Then, when you push down on the brake pedal, the air flows to the brake chamber for each wheel, where sufficient pressure is exerted to drive the brake shoes against the inside wall of the drums or the walls of the discs.

## Pressure amplification

The force of compressed air is used in conjunction with the principle of the lever to create a system that generates a considerable level of braking power.

When you push down on the brake pedal, the service reservoirs release air. This compressed air pushes against the diaphragm of the service brake chamber.



Applied parking brake



Parking brake air supply

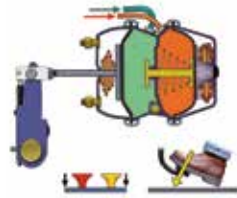

Applying the service brake

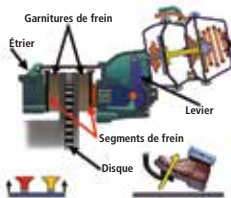

Applied parking brake

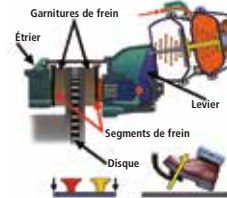

Parking brake air supply

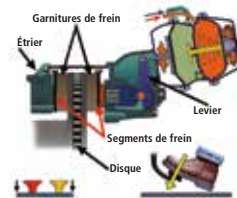

Applying the service brake

### ► Drum brake

The movement of the diaphragm pushes the push rod, which operates the slack adjuster. As it moves, the slack adjuster rotates an S-cam via a camshaft. The rotating S-cam pulls the brake shoes apart. This pushes the brake shoe linings against the drum and stops the wheel from turning freely.

### ► Disc brake

The movement of the diaphragm pushes a lever that exerts force (via a piston) on the brake shoe. The force so exerted pushes the brake shoe lining against the disc. An equivalent counterforce is simultaneously transmitted to the caliper, which pushes the opposing brake shoe lining against the disc. The pressure of the linings against the disc stops the wheel from turning freely.



The amount of braking power produced therefore results from the combined effect of several mechanical factors, such as:

- ▶ the pressure of the compressed air;
- ▶ the size of the brake chamber;
- ▶ the length of the slack adjuster;
- ▶ the rotation of the cam (for drum brakes).

You should also be aware that there is a limit to the braking capacity you can achieve when you push down on the brake pedal.

This limit is determined by the maximum amount of air pressure that the service reservoirs can supply and, in the case of drum brakes, the proper adjustment of the slack adjuster.

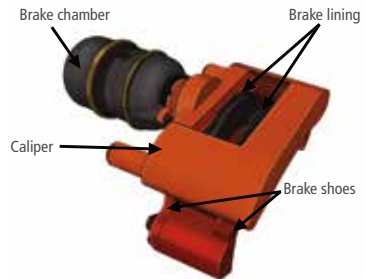
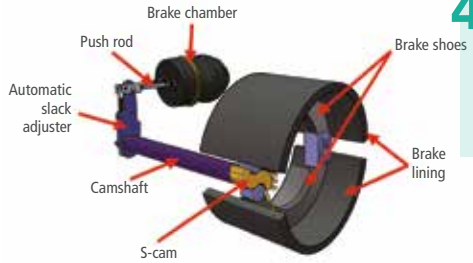

## Reaction time

Air brake systems are very efficient, but react more slowly than hydraulic brakes. To ensure that air brakes will react as quickly as possible, air brake lines have valves. By pushing down on the brake pedal, you send a signal to the first valve. Then the second valve (the relay valve) opens, allowing air to flow into the brake chambers. This way, there is always air on standby, so to speak, and it does not have to travel all the way through the lines before it can exert pressure on the brakes. This reduces the time it takes for air brakes to react.

Nevertheless, air brake systems are somewhat slower than hydraulic brake systems because air can be compressed but brake fluid cannot. It takes one-half second for air to pass through the system. During this time, a vehicle travelling at 90 km/h covers 12.5 m. When driving, you should therefore be aware of brake reaction time and the resulting increase in stopping distance.

The semi-trailer's service brakes operate at the same time as those of the tractor. This means that when you push down on the brake pedal, you activate the brakes on all of the vehicle's wheels.

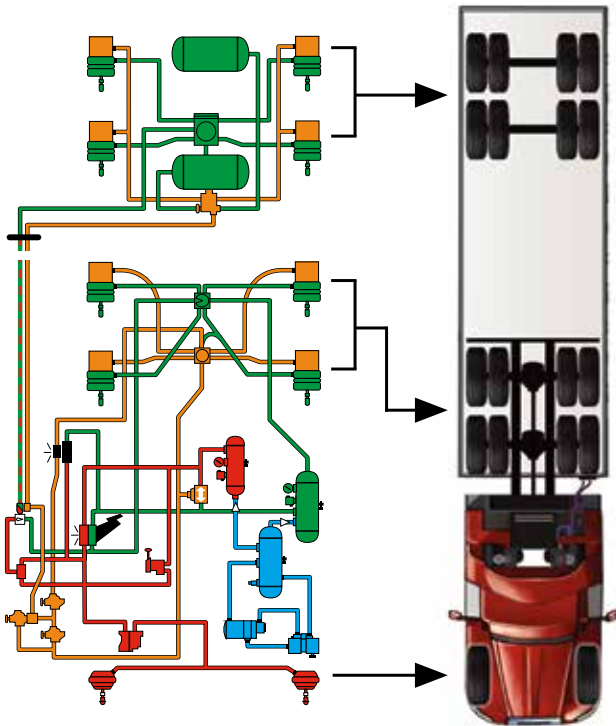

Example of a basic dual-line air brake system for a tractor semi-trailer.

The different colours show how the air is routed through the lines.

- |  |   |
|--|---|
| <span style="color: blue;">■</span> supply line                  | <span style="color: green;">■</span> rear axle service brake line |
| <span style="color: red;">■</span> front axle service brake line | <span style="color: orange;">■</span> parking brake line          |

## Braking power

It takes a lot of braking power to stop a heavy vehicle. It also takes more space to bring a heavy vehicle to a stop than it does a car, and this is all the more true if you are driving fast.

There are two factors that influence the braking power needed to slow down a vehicle or bring it to a stop: the vehicle's weight and the speed at which you are driving.

Brake systems are usually designed to be efficient as long as the vehicle does not exceed its gross vehicle weight rating (GVWR). This is the maximum weight recommended by the manufacturer and represents the weight of the vehicle plus the weight of the load. If the vehicle weight is over the GVWR, the brakes may not perform at optimum level and will wear out more quickly.

In theoretical terms, if the load you are carrying doubles the total weight of your vehicle, the stopping or braking distance is also doubled, provided the same amount of air pressure is applied on the brakes.



By doubling the pressure on the brakes, you can stop within the same distance, but the brakes will heat up twice as much. To alleviate overheating, you can either decrease your speed or increase the stopping distance. It is very important to never go over the vehicle's maximum authorized load: if you do, the brakes could fail completely.

The other important factor is speed. It is even more important than weight or load because the braking power required is proportionate to the square of the increase in speed.



Thus, when you double your speed, the braking power required is quadrupled. In other words, you have to provide four times more braking power to maintain the same braking distance. In turn, the brakes generate four times more heat. This is why you need to remain aware of the speed you are driving at.

Now that you understand the impact of weight and speed on braking, you can gauge the power required of your brakes to bring your vehicle to a stop. For example, if both your vehicle's weight and its speed are doubled, it will take eight times more braking power to immobilize it.



To keep your brakes working efficiently, you must maintain them in good condition and be careful not to push them beyond the capacity of the brake linings, the drums or the discs. Excessive braking can produce more heat than the drums and discs can absorb and disperse. The excess heat created by friction between the linings and the drums or discs causes the linings (or the brake) to become glazed and lose their effectiveness. This problem disappears when the linings cool down.

It is important to understand that brake system performance does not depend on brake power alone. Other factors have an impact, such as brake adjustment, the kind of brake linings used and their condition, what shape the tires are in, the grade of the road, the condition of its surface, and how aerodynamic the vehicle is.

# HOW THE PARKING BRAKE WORKS

The purpose of the parking brake system is to keep the vehicle stationary when parked. It immobilizes all the wheels of the vehicle equipped with a parking brake.

To activate the parking brake, pull up on the parking brake control knob once the vehicle is completely stopped. The air then empties from the brake chamber so that the spring in the brake chamber relaxes and exerts pressure on the push rod.



- ▶ In the case of a drum brake, the slack adjuster then rotates and squeezes the brakes.
- ▶ In the case of a disc brake, the lever pushes the brake linings against the disc and squeezes the brakes.

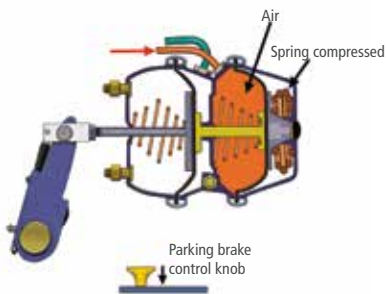

Spring squeezed by air:  
drum brake released

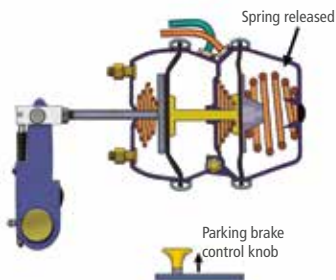

Spring released because of lack of air:  
drum brake applied

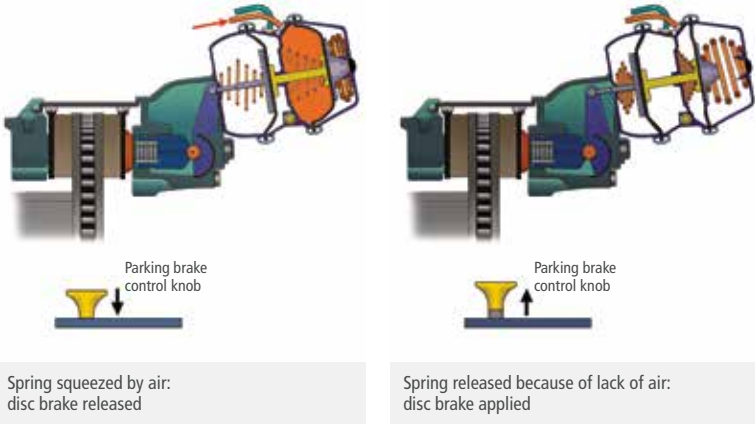

Conversely, when you release the parking brake, the air flows back into the brake chamber, compresses the spring, releases the brakes and allows the wheels to turn freely.

If you pull up on the parking brake control knob, the wheels of the tractor and the wheels of the trailer or semi-trailer all lock. Also, the trailer air supply control knob pops up automatically. However, if you pull up on just the trailer air supply control, this locks only the trailer or semi-trailer wheels.



# HOW THE EMERGENCY BRAKE WORKS

# 4

The parking brake system also serves as an emergency brake system. If the service brake system fails and prevents compressed air from flowing to the brake chambers, the emergency brake takes over and brings the vehicle to a stop. You can activate the emergency brake yourself. All you have to do is pull up on the parking brake control knob. The emergency brake is also activated automatically in an emergency situation, that is, when the air pressure in the service brake system drops below 242 kPa (35 psi).

Many things can cause a drop in air pressure, such as a broken hose or line, or a valve failure. When the emergency brakes are activated, the wheels equipped with brake chambers begin to lock as soon as the air pressure falls to 483 kPa (70 psi) or below. By the time the pressure drops below 242 kPa (35 psi), all the air has been evacuated from the brake chamber. At that moment, the emergency brake becomes fully engaged and the vehicle comes to a stop.

You are warned ahead of time, however, when an emergency is imminent. The low air pressure indicators are activated when the pressure in the service reservoirs drops below 380 kPa (55 psi). Some vehicle manufacturers go beyond this standard and calibrate the low air pressure warning threshold at 550 kPa (80 psi) to give the driver more warning time.

If your air pressure level drops to this critical level, you must react immediately. As soon as the low-pressure light or buzzer comes on, choose the best spot to stop your vehicle before the air pressure drops so low that the emergency brakes are activated and lock the wheels completely. If the mechanical problem is serious enough, the drop in air pressure can happen in the space of just a few seconds. Depending on the type of brake system, the rear wheels may lock abruptly and make it very difficult for you to control the vehicle.

# SUPPLEMENTAL BRAKE SYSTEMS

Many vehicles are equipped with a supplemental brake system to help you reduce vehicle speed. These brakes can be used alone or in combination with the service brakes. They allow you to slow down or stabilize vehicle speed in certain specific situations. However, they will not bring your vehicle to a stop.

These types of brake systems are options and do not come standard on your vehicle. They are added to other vehicle components. Engine brakes use engine compression, whereas retarders are installed on other parts of the vehicle.

There are various categories of supplemental brakes:

- ▶ An engine compression brake is installed on the engine and converts it into an air compressor. This is the most popular kind of supplemental brake on the market.
- ▶ An exhaust brake retarder or turbocharger also converts the engine into an air compressor by re-routing (choking) gases coming out of the exhaust pipe.
- ▶ An electromagnetic retarder (or eddy-current brake) uses the action of a magnetic field to slow the vehicle. The magnetic field causes softiron discs linked to a transmission component to rotate.
- ▶ A hydrodynamic (or hydraulic) retarder uses the pressure of motor or transmission oil to slow the vehicle.

Supplemental brakes are especially recommended when driving a heavily loaded vehicle and travelling down a steep grade. They allow you to maintain a constant speed without constantly applying your regular brakes.

However, you must pay careful attention to the noise generated by the use of engine brakes. Make sure that your vehicle's exhaust system is compliant and pay particular attention to its condition, notably, when you are making circle checks.



## How they work

# 4

Engine brakes and retarders are activated by means of a switch or lever. They are operable as soon as you switch them on or pull the lever, but do not begin to work until you take your foot off the accelerator.

For retarders to work effectively, you must first shift into the right gear. This remark more specifically applies to engine compression brakes, which work very efficiently at maximum RPM.

For instructions on operating the type of supplemental brake installed on your vehicle, refer to the manufacturer's operating manual.

No matter what kind of engine brake or retarder is installed on your vehicle, the braking power is always applied to the drive wheels.

# ANTI-LOCK BRAKES

When faced with an emergency, you have to apply your brakes as quickly as possible, exert maximum force and maintain control of your vehicle. In such situations, a vehicle equipped with an antilock brake system (ABS)—also referred to as an “antiskid brake system” or “anti-blocking system”—offers you several advantages, including greater vehicle stability, better steering control and, in some cases, shorter braking distance.

An anti-lock brake system goes into operation only when there is a risk of a wheel locking, such as when you have to apply the brakes abruptly. This is often the kind of situation where jackknifing and accidents occur. An ABS system helps to protect you against this.

With this kind of system, the braking force applied to the wheels is adjusted according to how well the tires grip the road. Sensors connected to a computer control the amount of air pressure flowing into the brake chambers so as to slow the vehicle down as quickly as possible without the wheels locking. Brake pressure is continually adjusted, based on vehicle speed and pavement conditions, to achieve optimal traction and braking.



If your vehicle is equipped with anti-lock brakes, when an emergency occurs, you must push the brake pedal all the way to the floor and hold it there. The anti-lock brake system automatically controls braking by producing a pumping effect.

# BRAKE INSPECTION

You should make sure your brakes are in good working order before you start out on each trip. The method for checking your brake system is described in Chapter 12.

Keep an eye on your pressure gauges and lights while you are driving and be alert for anything that seems abnormal when you apply your brakes. You may have to check your brakes during your trip under certain circumstances—if you are driving through a hilly or mountainous region, for example. There are special brake check areas indicated by a VÉRIFICATION sign. When you see this sign, you must pull over into the designated brake check area, park your vehicle at the stop sign and check your brakes.



# BRAKE ADJUSTMENT

For a heavy vehicle's brakes to work properly, it is not enough just to check that they are in good condition. They also have to be adjusted properly to ensure that maximum pressure is exerted by the brake linings on the drums or discs at all times.

Conversely, any type of brake—service brake, parking brake, emergency brake—that is poorly adjusted will never work efficiently. In a drum brake, for example, the pressure exerted by the brake linings against the drum will be insufficient if there is too much space between linings and drum, even if the gauges shows adequate air pressure in the brake system.

This is why the space, or clearance, between linings and drum must always be just right. However, the brake drum expands at high temperature; just how much it expands depends on what alloy it is made from. Also, it can wear out under pressure from the linings and become stretched or twisted, which increases the clearance between linings and drum.

The push rod must be able to bridge the gap so that the linings continue to press against the drum with all the pressure that the brake system supplies. It is essential to regularly check brake adjustment, even if you have automatic self-adjusting brake levers.

## Automatic self-adjusting brake levers

When a vehicle is equipped with automatic self-adjusting brake levers, this mechanism automatically compensates for any play between the brake linings and drums as the linings wear down.

## Preventive adjustment procedure

There is a simple procedure you can use to optimize the play or space between the linings and drums:

1. Make sure the brakes are cold.
2. Release the parking brake.
3. Bring the system up to maximum air pressure (120 psi).
4. Fully depress the brake pedal for five seconds and then release it completely.

Repeat this procedure four or five times in a row to complete the adjustment.



Although it is not mandatory, you can incorporate this adjustment into your circle check when you check the pressure regulator when the compressor comes on (19.3). If this procedure is not carried out on a regular basis, you should probably repeat step 4 more than five times for maximum play compensation.

## Manual brake levers

# 4

If your vehicle is not equipped with automatic self-adjusting brake levers, you will have to adjust the brakes manually. However, brake adjustment is a complex task that should be done only by mechanics or by drivers who have received specialized training.

# SELF-EVALUATION EXERCISES



## Theoretical Exercises

### True or false

---

1. Indicate whether the following statements are true or false.

	True	False
1. There is no reason why you cannot use the hand brake control on the road as a service brake.	<input type="checkbox"/>	<input type="checkbox"/>
2. Air brakes react just as quickly as hydraulic brakes when the driver pushes down on the brake pedal.	<input type="checkbox"/>	<input type="checkbox"/>
3. The parking brakes are applied to the wheels by means of compressed air pressure.	<input type="checkbox"/>	<input type="checkbox"/>
4. The service brake for the steering axle is always supplied by the primary circuit.	<input type="checkbox"/>	<input type="checkbox"/>
5. The braking power required to slow a vehicle or bring it to a stop depends on the vehicle's weight and speed.	<input type="checkbox"/>	<input type="checkbox"/>

Answers at the end of the guide.

# DRIVING KNOW-HOW AND ROAD SAFETY

5

---

Drivers of all types of heavy vehicles need to master the basic skills that allow them to control the speed and direction of their vehicle. Whether you are negotiating a curve, turning at an intersection or passing another vehicle, you need to know how to use the accelerator, steering wheel, brakes and transmission correctly.

In addition to these skills, you must learn how to observe your driving environment and adapt to it. When it has become second nature for you to check your blind spots, use the rearview mirror, signal your intentions and maintain adequate space around your vehicle, you will be prepared to cope with the most complex driving situations and react optimally. These skills and behaviours are essential for becoming a safe, cooperative and responsible professional driver.

Become a professional by adopting the right attitude from the very beginning.



# KEEP YOUR EYES OPEN

# 5

Research has shown that distraction on the part of the driver plays a role in the majority of accidents. To drive safely, you need to be constantly on the lookout so that you are always aware of everything that is happening in front of your vehicle and on either side. You should pay special attention to blind spots and to what you see in your rearview mirror.

## Look well ahead

All drivers look ahead of them, but many of them do not look far enough ahead. Manoeuvres such as stopping or changing lanes take longer and require a greater distance in a heavy vehicle than in a car, so you need to look well ahead to be sure you have enough available space to execute each manoeuvre in a safe and controlled manner. Always looking far ahead protects you from being caught off guard and ensures that you maintain control over your vehicle at all times.



Looking far ahead requires you to scan the distance you will be covering in the next 12 to 15 seconds, but be careful to avoid staring off into the distance. A time interval is a good way to estimate distance. The advantage of this method is that it works at all speeds. In cities and residential areas, this might be the equivalent of the distance between two intersections. On highways, where traffic moves faster, you need to look about one-half kilometre ahead. This will give you enough space to adjust your speed or change lanes if necessary.

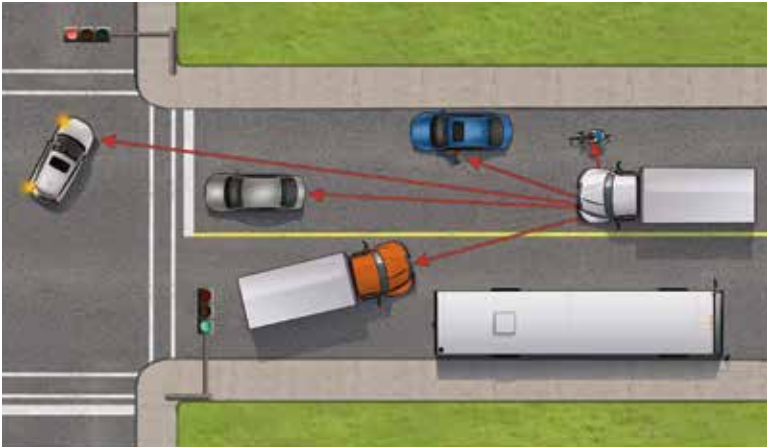

Obviously, looking far ahead does not mean you can ignore what is happening closer to you. You should keep an eye on traffic flow and on vehicles that are about to merge with traffic, change lanes or make a turn.

By remaining observant and anticipating events well in advance, you can perform the necessary manoeuvres, adjust your speed and avoid having to brake abruptly.

## Check blind spots

## 5

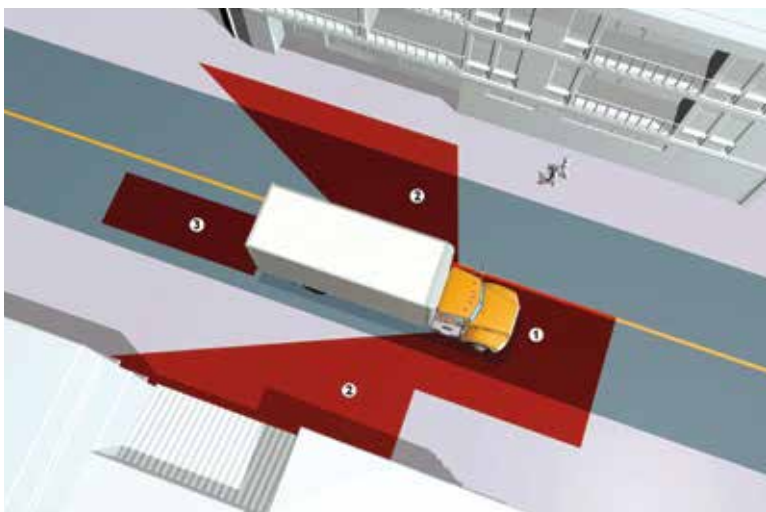

You should bear in mind that it is difficult to observe everything going on around you. Even with convex rearview mirrors, there are certain areas of the road that you cannot see, especially blind spots. Be extra careful about other vehicles travelling close to you so as to avoid manoeuvres that might hinder other drivers.

To check your blind spots, look back at the areas behind you on your right and left that are not covered in your rearview mirrors. Make sure these blind spots are clear before you change lanes, make a turn, back up or start moving. Remember that your vehicle is bigger than the others around you. This makes it all the more important for you to check your blind spots for the presence of smaller vehicles, cyclists or pedestrians.

## Check rearview mirrors

You should know what is happening around your vehicle at all times. Use your rearview mirrors to check the traffic beside and behind you, and do so at regular intervals, every 10 or 12 seconds in normal conditions and more often in problem situations. This ensures that you will be able to safely change lanes, make turns or react to an unexpected hazard.



## A quick glance

Since you cannot look ahead and in your rearview mirror at the same time, you should take quick glances, shifting your eyes from the road up ahead to the mirror and back again. Avoid looking in the rearview mirror for too long at a time because the situation ahead of you is constantly changing.

## Understanding what you see

If one of your tires is overheating or on fire, the rearview mirrors also allow you to see this quickly. On some types of vehicles, they can be used to check on your semi-trailer and cargo to make sure it is well secured.

Most heavy vehicles are equipped with convex rearview mirrors that provide a wide-angle view, but they also make everything look smaller and farther away. Keep this in mind when changing directions.

## Signal your intentions

When you are driving, other drivers do not know what you are planning to do unless you tell them. This is why you must signal your intentions clearly and make sure other road users understand what you are planning to do. This will prevent many problems and help you avoid accidents. Once you are sure that you can make your move safely, signal your intentions. Here are some of the situations where you need to signal your intentions using turn signal lights.

### Turning

You must signal your intentions as soon as possible so that other drivers will have enough time to make allowance for the fact that you are about to make a turn and can avoid getting in your way. Turn on your signal lights as soon as you can be sure other drivers will not be at risk of mistaking your intentions, leave them on to make your intentions clear, and do not turn them off until you have completed the manoeuvre. You should start signalling your turn before you begin slowing down, unless you have to start slowing down so far in advance of making your turn that using your turn signal could confuse other drivers.



### Changing lanes

Signal your intention to change lanes well in advance. After making the usual checks and clicking on your turn signal, begin to move gradually into the adjacent lane.

### Slowing down and stopping

In cities and towns, you have to slow down or even stop your vehicle frequently. You must therefore pay close attention to other vehicles and avoid having to make abrupt moves. Your brake lights let other drivers know when your vehicle is slowing down or stopping. Avoid braking abruptly.

# ALLOW YOURSELF ENOUGH SPACE

When driving, avoid following other vehicles too closely or taking a route where the roadway is not wide enough for your vehicle. Allow yourself enough space in front and to the sides to manoeuvre.

## Space ahead

When you come to a stop behind another vehicle, you should try to leave enough space so that you can pull out around the vehicle in front of you, if you have to, without having to back up. Likewise, you should always allow enough space in front of you when driving so that you can brake or stop easily if an unexpected hazard arises.

Counting the seconds is a good way of determining how much space to leave between your vehicle and the one ahead of you. To ensure that you are following at a safe distance, allow one second for every three metres in length of your vehicle, provided the pavement is dry. For example, if you are driving a heavy vehicle that is 12 m long, you should allow 4 seconds between you and the vehicle ahead. For a tractor-trailer 18 m long, you should allow 6 seconds.

#### How to count the seconds:

1. Choose a stationary object by the side of the road as a reference point, a little ahead of vehicle A in front of your own vehicle B.



2. When the rear of vehicle A passes the reference point, begin counting out the seconds like this: "one thousand and one, one thousand and two" and so on.



3. If you reach the reference point after counting out the full number of seconds, you are following at the right distance, under normal driving conditions.

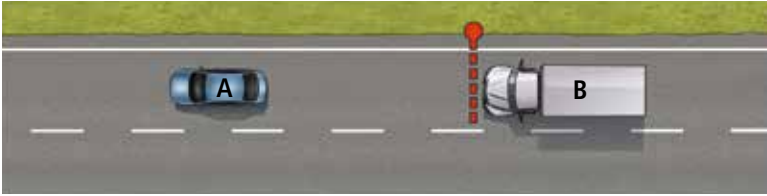

4. However, if you reach the reference point before you have finished counting out the full number of seconds, you are following too closely.

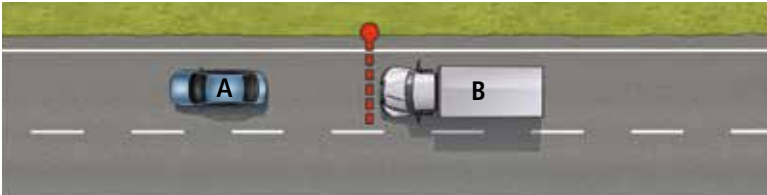

You should increase the distance if you are travelling at speeds over 60 km/h or driving at night, and you should double the distance when driving on wet pavement, triple it when driving in snow, and quadruple it when driving on icy pavement.

## Space behind

Most heavy vehicles are designed in such a way that it is practically impossible for you to see vehicles following close behind you. Furthermore, when you are forced to drive more slowly, particularly in cities and towns or in conditions of poor visibility, motorists tend to follow you closely.



Since there is no way you can prevent other drivers from tailgating you, you have to make allowance for their presence. Here is how to avoid problems:

- ▶ First, be careful and be ready at all times to respond to any change in the situation.
- ▶ Avoid making abrupt manoeuvres if you have to change lanes or turn.
- ▶ Signal your intentions ahead of time and before you brake, if the manoeuvre you are preparing to execute requires you to do so.
- ▶ Increase the distance between yourself and the vehicle ahead of you. Leave enough space so that another vehicle attempting to pass you can easily pull back over into your lane ahead of you.
- ▶ Do not use your brake lights as a warning to the other driver against following you too closely.

## Space to the sides

A heavy vehicle occupies almost the full width of a traffic lane. To drive safely, maintain your vehicle in the centre of the lane and avoid straying into other lanes. Look well ahead of you to the centre of the lane in which you are driving; this will help you to maintain your vehicle in the centre of your lane.

Whenever possible, drive defensively and make sure that other drivers can see you.

Strong winds or blowing snow can make it difficult for you to stay in your lane without wandering into an adjacent lane or onto the shoulder of the road. The way your vehicle reacts to crosswinds varies, depending on whether or not you are carrying a load (all the more so if the road is covered with snow or ice), particularly when your



vehicle is emerging from a tunnel or travelling under an overpass. In high winds, slow down. Also, keep an eye out for signs indicating that you are approaching an area of high winds or blowing snow.

## Space overhead

To be a good driver, you must be aware of the size of the vehicle you are driving—especially the height of the vehicle and its load—so that you can avoid striking overhead structures such as bridges or overpasses.

The following suggestions will help you avoid this danger:

- ▶ Do not automatically assume that the heights posted at bridges and overpasses are correct. Repaved roads, ice or packed snow can reduce clearance. If you are not certain that you have enough overhead space when approaching a bridge or overpass, stop and check to make sure.
- ▶ The weight of your load can affect the height of your vehicle. For example, an empty trailer rides higher than a loaded one.



- ▶ On some roads your vehicle may tilt, causing you problems clearing roadside objects such as trees or road signs. If there is an actual risk of hitting them, drive your vehicle a little closer to the centre of your lane, but be very careful not to trespass into the adjacent lane. Remember that there might be other vehicles approaching you from ahead or behind.
- ▶ Before backing up, make sure you have enough room. Ice on electrical wires, branches or other overhanging objects can reduce your clearance and block your way.



## Raised dump body light and sound warning system

Moreover, since 2019, all dump trucks and road tractors that carry dump trailers or semi dump trailers must be equipped with a warning system that is automatically activated until the dump body is completely lowered. Fines are applicable if such vehicles are not equipped with this safety feature.

# NEGOTIATING A CURVE

Curves come in all shapes and sizes. Even if there is a sign indicating the configuration of the curve you are approaching, you should visually check, as far in advance as possible, to see how sharp the curve is. This means looking well ahead so that you can anticipate different scenarios and plan the right moves. Even though you cannot alter the configuration of the curve or the condition of the pavement, you can control your vehicle's speed. In fact, your speed is the crucial factor to consider when negotiating a curve.

In order to slow down, it may be enough to remove your foot from the accelerator or downshift. If you have to brake, though, make sure that you do so before you go into the curve, while your vehicle is still travelling in a straight line. It is important to choose a gear that will enable you to accelerate slightly once you are in the curve in order to keep your vehicle stable.

Because most heavy vehicles have a high centre of gravity, the driver must demonstrate a high degree of skill when negotiating a curve. Going into a curve at high speed could cause you to lose control of your vehicle, swerve or even overturn.

Avoid braking or downshifting in curves. Instead, you should make sure that you are in the right gear before entering the curve.

Once you are in the curve, keep an eye on oncoming vehicles to make sure they are not straying too close to the centre line. Before entering a curve turning to the right, edge your vehicle close to the centre line or the far left side of the lane you are driving in. Hold this position until you exit the curve, then move back to the middle of your lane.

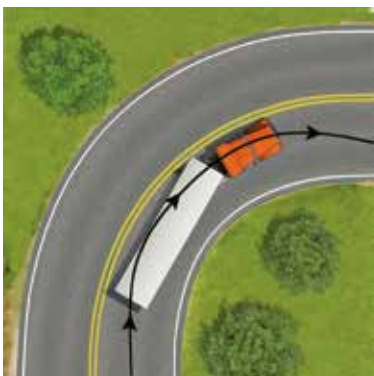

Negotiating a right curve with a tractor semi-trailer

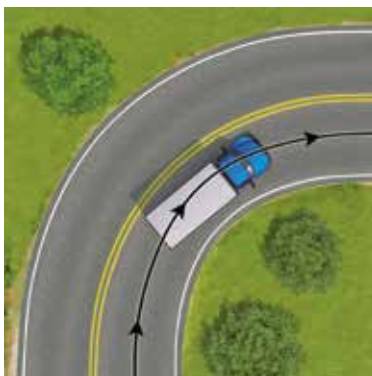

Negotiating a right curve with a straight-body truck or a bus

Before entering a curve turning to the left, edge your vehicle over to the right side of the lane you are driving in. Hold this position until you exit the curve, then move back to the middle of your lane.

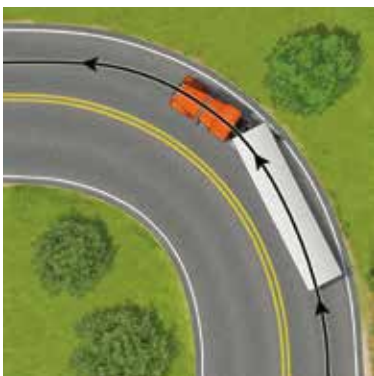

Negotiating a left curve with a tractor semi-trailer

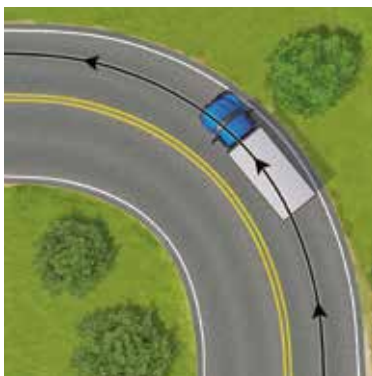

Negotiating a left curve with a straight-body truck or a bus

As you are exiting the curve, accelerate gradually to resume your normal cruising speed.

# TURNING AT AN INTERSECTION

Turning at an intersection involves the risks of straying into other lanes or onto the median, striking obstacles or causing an accident. Be very careful!

## The basics

To make a safe turn, follow the steps outlined below:

### As you are approaching the intersection:

- ▶ Make sure you are in the proper lane for turning.
- ▶ Gradually slow down and adjust your speed to avoid having to brake or downshift while you are turning.
- ▶ Check your rearview mirror and blind spots, then signal your intentions.
- ▶ Shift into the right gear before turning to avoid having to shift gears during the turn, if your vehicle has a manual transmission.
- ▶ Check to make sure you have enough space, considering the size of your vehicle and any obstacles.

**As you are turning:**

- ▶ Check the driving environment throughout the manoeuvre.
- ▶ Begin your turn as soon as your vehicle enters the intersection.
- ▶ Accelerate gently as you are coming out of the turn.

Whether you are turning right or left, this manoeuvre requires you to exercise a high level of skill and make continuous visual checks.

When turning at an intersection, you must take into account the fact that your rear wheels trace a shorter path than your front wheels. To compensate for this, you should steer the front of your vehicle so as to use all of the available space. Sometimes you may even have to encroach on the next lane, either left or right, with your front wheels in order to complete the manoeuvre (see illustrations), although this is prohibited by law in some situations. If you have to do this, make sure there is no risk of your rear wheels trespassing onto the sidewalk, onto the shoulder or into another lane. Keep the space between your vehicle and the side of the road as small as possible to prevent pedestrians or other vehicles from venturing into this space.

## Right turns

Signal your intentions and then make your turn as follows:

5. Keep your vehicle in the right lane and be on the lookout for other road users (vehicles, cyclists, motorcyclists, pedestrians, etc.) that might venture into the space between the side of the road and your vehicle.
6. After checking left, right and then left again to make sure that the way is clear, start making your turn holding the front end of your vehicle close to the dividing line on the left side of the lane you are entering. Even though it is prohibited by law to do so, road configuration and vehicle size sometimes leave you no other choice but to encroach slightly on the next lane. If you have to do this, make sure the way is clear and remain alert to vehicles that might appear unexpectedly.

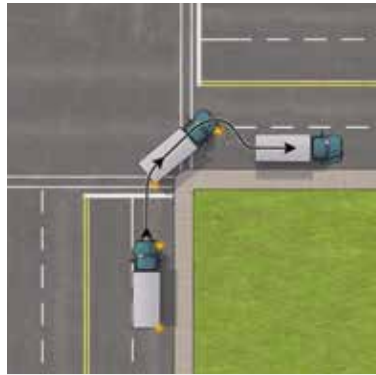

Turning right with a straight-body truck

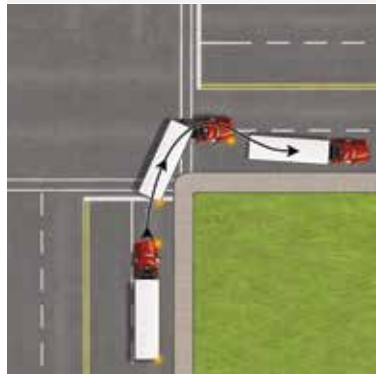

Turning right with a tractor semi-trailer



Turning right with a bus



7. Continue straight ahead, close to the dividing line, and make sure your rear wheels do not trespass onto the sidewalk or shoulder.
8. Steer your vehicle back to the centre of the lane.

Limit the space between your vehicle and the side of the road as much as possible, and be alert throughout the manoeuvre to prevent pedestrians or other vehicles from venturing into this space.

## Left turns

Signal your intentions and then make your turn as follows:

1. Steer your vehicle into the appropriate lane, edging over to the right-hand side of the lane, if necessary.
2. After checking left, right and then left again to make sure that the way is clear, proceed and steer your vehicle so that its front end is close to the dividing line of the other road and edge over to the right side of the lane you are entering. If you do not have enough space, it is sometimes necessary to encroach slightly on the other right-hand lane after making sure the way is clear. Be on the lookout for other road users (vehicles, cyclists, pedestrians, etc.) that might appear unexpectedly.

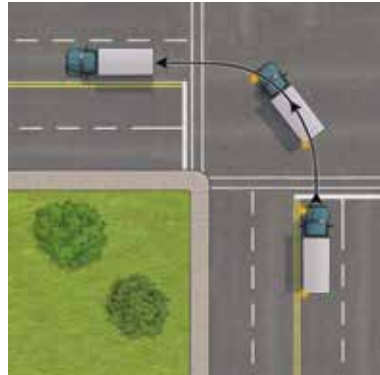

Turning left with a straight-body truck

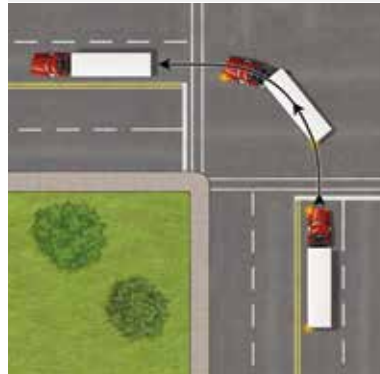

Turning left with a tractor semi-trailer

3. Continue straight ahead, close to the right-hand dividing line, until you have almost completed your turn, making sure that your rear wheels do not cross over the centre line.
4. Steer your vehicle back to the centre of the lane.

With certain configurations of heavy vehicles, you may have to encroach on the far right-hand lane to complete your left turn. By doing this, you can avoid having to make successive lane changes after turning. If you have to do this, however, you must be very careful, because if there is another vehicle in a parallel lane turning left at the same time as you or coming from the opposite direction and turning right, that other vehicle has the right of way.

If there are two lanes from which left-hand turns are permitted, you should make your turn from the outside or far right lane so as to avoid trespassing into the adjacent lane. Another advantage of doing this is that you can be sure there will be no other vehicle to your right (in which case, you might not be able to see it) attempting to turn left at the same time as you. But be very careful when performing this manoeuvre, since it may surprise any driver in the other left turn lane (to your left) who is also turning left.

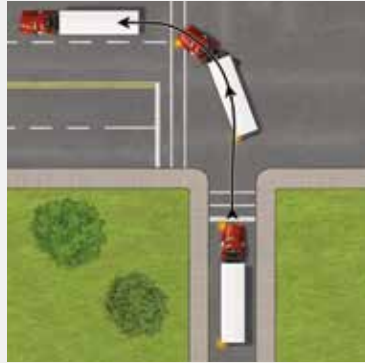

## BRAKING DISTANCE

Good drivers should be able to control their speed at all times. The faster you drive, the less time you have to react and the greater the braking distance. Road conditions can change very quickly when you are driving and the distance you travel in only one second can make the difference between stopping safely or having an accident.

## HOW TO BRING YOUR VEHICLE TO A STOP

Heavy vehicle drivers should use their gears not only when speeding up but also for slowing down. This way, engine compression helps you slow down your vehicle. Furthermore, if you should need to speed up again, you will already be in the right gear to do so.

To slow down or stop quickly, you should use your transmission (downshift) and brakes in combination. You can use your regular brakes or, where permitted, your supplemental brake system. Downshifting and braking at the same time puts less of a strain on your brakes. Once you have come to a stop, it is a good idea to shift to neutral if you are going to be stopped for a while.

Whether you drive a tractor-trailer, bus or straight-body truck, it is important to make sure you have enough space to come to a stop. This will keep your passengers safe and comfortable or prevent damage to cargo.

By following these recommendations, you can avoid having to make abrupt stops. When you brake abruptly with a heavy vehicle, the vehicle's weight produces a strong forward momentum that can cause you to lose control. Depending on road conditions, this can send the vehicle into a skid and cause an accident resulting in severe damage.

#### TO AVOID ABRUPT STOPS:

- ▶ Adjust vehicle speed to traffic conditions and maintain a safe distance between you and the vehicle up ahead (counting the seconds as described above).
- ▶ Look up ahead, to the sides and in the rearview mirrors so that you are always aware of traffic conditions.
- ▶ Anticipate where and when you will have to stop.

## Factors that influence braking distance

As a heavy vehicle driver, you must be aware of the various factors that can affect how you should drive your vehicle. For example, to slow down or come to a stop, you have to adjust your driving based on the following factors:

### Weight of the load

The load you are carrying has an impact on braking distance. Heavy vehicle brake systems are designed to be effective on vehicles loaded with a cargo up to the manufacturer's gross vehicle weight rating (GVWR). This means that if the weight of your load is doubled and you apply the same brake pressure, it will take you a greater distance to come to a stop.

## If you double the weight, you need double the braking power

If your gross vehicle weight is over the allowed limit, your vehicle is considered to be overloaded and greater braking power is required—often more than the brakes' normal capacity. Brake systems are not designed to handle this excess weight. In such a circumstance, braking distance might be increased even more if the brake drums and linings become overheated, causing a loss in braking efficiency.

## Vehicle speed

However, speed has a much greater impact on stopping distance than the weight of the load, taking into account the brake system's limits, of course. The faster you drive, the greater the distance it will take you to come to a stop. For example, if you double your speed, your stopping distance is quadrupled, assuming the same pressure is applied to the brakes. By slowing down just a few kilometres an hour, you can greatly reduce your stopping distance.

## Perception time, and human and machine reaction time

The estimated time lag between when the driver sees a danger and when the brakes begin to slow the vehicle is two seconds. You must factor in this delay in order to brake safely.

## Road conditions

In most cases, the driver has some control over factors such as load and speed, but road or pavement conditions are beyond your control and can reduce the traction you need to maintain control of your vehicle when braking. In such a situation, the only way you can be sure of coming to a stop within normal braking distance is by reducing your speed. Braking distance is at least doubled on icy pavement as compared to dry pavement. For example, at 60 km/h, it takes approximately 45 m (140 ft) to come to a complete stop on dry pavement and 80 m (260 ft) on icy pavement.

**So slow down—to below the posted speed limit—and avoid braking abruptly.**

# BACKING UP

## Things to check when backing up

Backing up causes various problems for drivers of heavy vehicles. It is usually impossible, using just your rearview mirrors, to see what is directly behind your vehicle, particularly when backing into a small space. Although it is preferable to back up as seldom as possible when driving a heavy vehicle, this is a manoeuvre that you will be required to perform fairly often—when approaching a loading dock, for example. Obey the following rules and you will be able to back up safely.

### Before backing up

Before you begin backing up, it is essential for you to take a moment to look at the layout of the surrounding area.

If necessary, get out of your vehicle to assess the situation: check the condition of the road surface, note the location of any stationary objects, and anticipate any potential pedestrian and vehicle traffic that might hinder your manoeuvre.

Check carefully for any obstacles overhead or to the sides of the vehicle that might get in your way.



## Back up slowly

Once you have finished checking the layout, begin backing up immediately, before there is any change to the situation as you just observed it.

Backing up slowly is the key to completing the manoeuvre safely and successfully. By taking it slow, you will find it easier to correct steering errors, estimate distances and stop the vehicle if need be. Steering errors should be corrected immediately.



## Visibility of the trailer or semi-trailer while backing up

After dark, when backing up in such a way that you obstruct the lane reserved for oncoming traffic, your trailer or semi-trailer could become harder to see for drivers coming from the opposite direction.

Here are three recommendations to increase your vehicle's visibility during this manoeuvre:

1. Use your hazard lights.
2. Do not turn on your headlights (high beams)—they could blind other drivers.
3. When possible, plan to arrive on the same side as the loading dock.

## Backing up toward the driver's side

You should back up by steering the rear of the vehicle toward the driver's side (to the left) if at all possible because this allows you to see a part of the area behind the vehicle. Look through the left side window and use the left rearview mirror if the angle between the tractor and the trailer allows you to do so. With a bus or a straight-body truck, you are in a better position to use the left rearview mirror, but you must regularly check the right rearview mirror and the side window to complete the manoeuvre safely. By using your rearview mirrors properly, you can see whether you are steering your vehicle in the right direction and be sure you can continue backing up safely.

## Have a helper guide you

It is always better to have a helper to guide you whenever you are backing up, especially when backing up toward the right. Choose someone reliable and make sure the person understands what to do and what signals to use. Your helper should keep an eye on the space available behind and on either side of your vehicle, and should also help you correct your vehicle's position where necessary.



**IMPORTANT:** Your helper must make sure that he or she is visible to you at all times.

As a rule, when you are backing up toward the left, your helper should stand behind your vehicle off to the left side; when you are backing up to the right, he or she should stand behind the vehicle off to the right side. This way, your helper can maintain visual contact with you.



## How to back up

Backing up a heavy vehicle toward the right or the left requires the driver to pick out a pair of visual reference points and then steer backward using these two points.



5

To perform this manoeuvre, you must maintain visual contact with these reference points as you line them up together. These two points are:

- ▶ the rear corner of your vehicle on the side toward which you are backing;
- ▶ the farthest rear edge of the loading dock or parking space toward which you are backing your vehicle.

To back up turning left or right with a bus or straight-body truck, you must turn the steering wheel toward the side to which you are steering the rear of the vehicle until both reference points are lined up side by side: toward the right if backing to the right and toward the left if backing to the left.

To back up turning either right or left with trailer hitched to a tractor, the manoeuvre is different. While maintaining visual contact with the two reference points, turn the steering wheel in the opposite direction from that toward which you want to steer the trailer.

## Backing up toward the right

1. First turn the steering wheel to the left so that the semi-trailer backs up toward the right, while aiming the semi-trailer so as to line up the two reference points.
2. Then turn the steering wheel to the right so that the tractor also backs up toward the right, and continue backing up until the two reference points are lined up side by side.

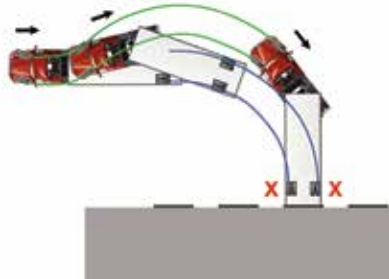

## Backing up toward the left

1. First turn the steering wheel to the right so that the semi-trailer backs up toward the left, while aiming the semi-trailer so as to line up the two reference points.
2. Then turn the steering wheel to the left so that your tractor also backs up toward the left, and continue backing up until the two reference points are lined up side by side.

## Backing up in a straight line

The same rules apply when you want to back your semi-trailer up in a straight line. If the trailer begins to veer off left or right, turn the steering wheel to steer the tractor in that direction so as to correct for it. In some cases, the trailer may veer so far out of line that you will have to correct the tractor-trailer alignment by stopping your vehicle, pulling forward, and then beginning to back up again.

# CHANGING LANES

# 5

1. Before you decide to change lanes, make sure that the manoeuvre is allowed and that it is safe to do so.
2. Check to see how heavy the traffic is and how fast the other vehicles are moving; you must also check your rearview mirrors and your blind spots to see if there are other vehicles, cyclists or pedestrians travelling beside you or about to overtake you.
3. Click on the turn signal light to indicate you are about to change lanes.
4. Check your rearview mirrors once more, then check your blind spots to make sure it is still possible for you to change lanes and to determine, among other things, whether the distance between your vehicle and other vehicles has changed in the meantime.

Once you have completed these steps, steer your vehicle slowly but steadily into the other lane. This will signal to other drivers that you are in the process of changing lanes and they will be able to adjust to your movements.

# PASSING

The things you need to check before passing another vehicle and the procedure for doing so are the same as for changing lanes. Basically, passing means changing lanes twice: first into the left lane, then back into the right lane. Do not forget to turn off your turn signal lights after each lane change.

Remember that you need a greater distance to pass because the heavy vehicle you are driving is considerably longer and heavier than an automobile.

Avoid using your horn when passing, unless absolutely necessary. Using your horn can startle other drivers, with unpredictable results. If you are driving at night and you need to pass, you can flick back and forth from high to low beams to signal your presence to the other driver. Before you make any move, be sure that the other road users understand what you are preparing to do: do not just assume that they have understood.

## Do not signal others to pass you

Some people mistakenly think they are being helpful by signalling to other road users when to pass. However, there may be people or vehicles that they are unable to see. Also, drivers who pass when someone else is signalling them to go ahead may be affected by a false sense of confidence and become less alert for unexpected moves by others. You should concentrate on signalling your own intentions instead of signalling to others what to do.

# DRIVING UPHILL

# 5

When driving up a hill, you must make sure you can remain in control of your vehicle and deal with unexpected hazards.

Your vehicle may already be travelling fast enough to go up a gentle grade, without requiring you to downshift if your vehicle is equipped with a manual transmission. You merely have to accelerate slightly to get enough power from the engine to keep your vehicle moving at a constant speed.

On a steeper grade, however, you have to use your transmission properly to obtain the best performance from your engine. This means that as you go up a grade, you must be able to judge the proper moment for downshifting to achieve maximum efficiency. Properly timing your gear changes is especially important when you are carrying a heavy load. Mastery of proper technique is essential.

If you need to start your vehicle on an uphill grade, it helps to use your service brake to keep your vehicle from coasting backwards. When you are ready to move forward, ease off the clutch until you feel the friction point, release the service brake pedal, then gradually push down on the accelerator.

# DRIVING DOWNHILL

## Check road signs and signals

Signs are usually posted to warn drivers of any exceptionally steep grade in the road up ahead. You should pay special attention to the percentage on the sign because the higher the percentage, the steeper the grade. If the grade extends for more than one kilometre, that fact is indicated on the sign.

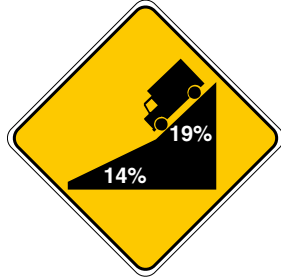

## Check your brakes before starting down a hill, no matter what kind of brake system you have

This recommendation is of the utmost importance no matter how steep the grade you are about to drive down. For example, the sign illustrated opposite indicates that the driver is approaching a grade of 150 m for every kilometre over a distance of at least 3 km. The sign above it indicates that the driver is approaching two different grades, one immediately following the other and each with a different grade percentage.



## Mandatory check

In some places, there are special signs requiring you to pull over at a specific spot and check your brakes. The sign shows the distance ahead before reaching the brake check area. When you arrive there, you will see the VÉRIFICATION<sup>1</sup> sign indicating that you must come to a full stop before the Stop sign.

If it has been a while since the last circle check, it would be wise to repeat the brake check procedure required for the circle check, as explained in Chapter 12.



<sup>1</sup> The VÉRIFICATION sign announcing a brake check area indicates the obligation for the drivers of vehicles or combinations of vehicles whose total loaded mass is at least 3,000 kg to check the condition of their brakes themselves, having stopped where required.

## Driving down a gentle grade

On a gentle grade, letting up slightly on the accelerator may be all you need to do to control your speed.

## Driving down a steep grade

Before driving down a steep grade, however, you must make sure your brakes are working properly by pushing down on the brake pedal. You must then slow down and adjust your speed so that you can drive down the hill at a safe speed. Once you have reached that speed, before starting down the grade, select the appropriate gear. **Avoid changing gears as you are going down the grade.** If the grade is very steep, we also suggest that you use engine compression and retarders (if your vehicle is equipped with them).

## Using your brakes when driving down a steep grade

If you apply your brakes repeatedly or over an extended period of time while driving down a long grade, they may overheat and fail to work properly when you need them. This is why it is so important, before you start down the hill, to shift into the right gear to maintain control of your vehicle all the way down.



Despite this, you may still need to use your brakes when going down a long grade. If so, here is how to apply the brakes:

1. Push down hard enough on the brake pedal to actually feel the vehicle slowing down. If your vehicle is equipped with air brakes, avoid pumping the brakes because this will quickly reduce the air pressure in the reservoirs.
2. Once you have reduced your speed to about 10 km/h below the speed considered “safe,” take your foot off the brakes.
3. When the vehicle has once again reached the speed you consider safe, repeat steps 1 and 2 so as to maintain control of your speed.

For example, let’s say that you are going down a hill where the safe speed is 50 km/h. Your speedometer shows 55 km/h. Since the safe speed is 50 km/h, you must use the brake pedal to reduce your speed to 40 km/h. Once you have reached that speed, take your foot off the brakes. When your speed has climbed back up to 50 km/h, reduce your speed once again to 40 km/h to keep your vehicle’s speed under control. Repeat this procedure as many times as you need until you have reached the bottom of the hill.

# SUPPLEMENTAL BRAKES

In certain situations, particularly when your vehicle is loaded, you can use your supplemental brakes to help you maintain the desired speed without overusing your service brakes. If your vehicle is equipped with a supplemental brake, you should make sure it is working properly before you start downhill. All you need to do is activate the switch and release the accelerator.

You should be aware that supplemental brakes are most fully effective when applied at the point when the engine is turning at maximum RPM for a given gear.

Once you reach the bottom of the hill, increase your speed and shift to the appropriate gear.

## Using your transmission and engine compression to slow down on a downhill grade

Before driving down a steep grade, you should shift into a gear that allows you to maintain control of your vehicle's speed. Manufacturers' manuals state that you get the greatest braking effect from the engine in first gear and that the general practice is to shift into first before starting down a steep grade.

You should stay in this gear all the way down. By using the lowest gear appropriate for the grade, engine compression helps slow the vehicle down and control its speed. Compression is effective whether your vehicle is equipped with standard or automated manual transmission.

## Automated manual transmission

Heavy vehicles equipped with manual transmission have become less popular in recent years with the growing popularity of automatic transmission (see Chapter 3). Automated manual transmission is also beginning to make an impact on the market. This type of transmission functions in the same way as manual transmission. It is synchronized by an electronic system that enables you to slow your vehicle down without danger, since the transmission downshifts or stays in gear only if there is no risk of mechanical failure.

You can also shift to a lower gear than the highest gear automatically selected. The resulting engine compression can be helpful when driving down a hill. Choosing a lower gear prevents the transmission from automatically shifting into a higher gear. The resulting braking effect can be helpful in some situations, but keep an eye on the engine to make sure it does not begin turning at too high a speed (RPM). This is particularly useful on a road with a steep grade: shifting into a lower gear prevents the transmission from making frequent or unplanned gear changes, for example, on slippery pavement or on an uphill or downhill grade.

## Pulling over to the side of the road

If you need to pull over to the side of the road, you should turn on your hazard lights. This is especially recommended at night, so that other drivers will not be fooled into thinking your vehicle is still moving and attempt to follow you.

In the event of a breakdown, in addition to hazard lights, you should use flares or red reflectors to show that your vehicle is stopped. If using flares, remember to replace them when they burn out so to maintain a continuous warning signal.

Use of flares is prohibited if your vehicle is carrying flammable, explosive or dangerous substances or materials such as fuel, paint thinners, propane gas or dynamite.

There are two procedures for positioning warning signals, depending on whether you are stopping on a secondary road or a highway.

## Pulling over on a secondary road

On a secondary road, warning signals should be placed as follows:

1. The first warning signal is placed on the ground approximately 3 m behind the stopped vehicle and in line with the left side of the vehicle.
2. A second warning signal is placed on the ground approximately 30 m behind the vehicle and in line with the first warning signal.
3. A third warning signal is placed approximately 30 m ahead of the vehicle and in line with the left side of the vehicle.

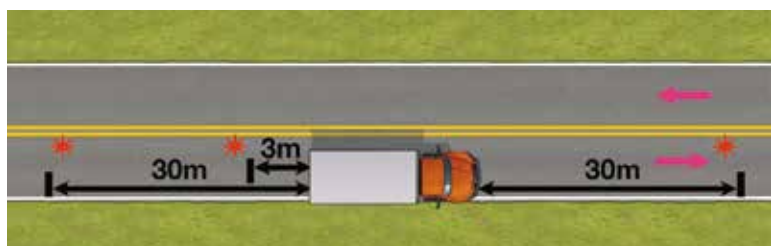

## Pulling over on a highway

## 5

On a highway, a one-way road, or any other public thoroughfare where there is no oncoming traffic, warning signals should be placed as follows:

1. The first warning signal is placed on the ground approximately 3 m behind the stopped vehicle and in line with the left side of the vehicle.
2. A second warning signal is placed on the ground approximately 30 m behind the vehicle and in line with the first warning signal.
3. A third warning signal is placed on the ground approximately 60 m behind the vehicle and in line with the other warning signals.

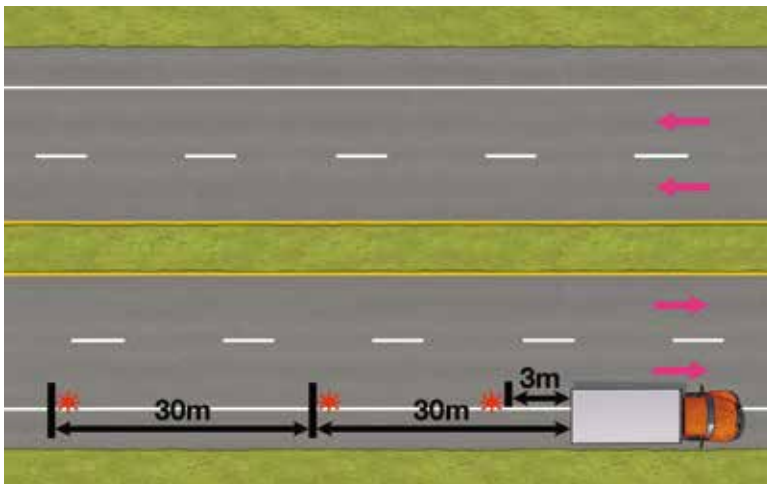

## Level crossings

Heavy vehicle drivers must be cautious when approaching a level crossing. Road signs marking the location of a train track may be wholly or partially obscured at certain times of the year due to snow, weeds or even tree branches.

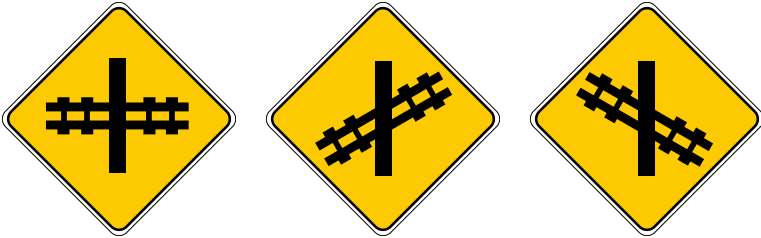

Heavy vehicle drivers must also be conscious of the risk of colliding with a train at level crossings. Because of their size and the cargo they carry, heavy vehicles usually take longer than other vehicles to cross train tracks. Avoid having to change gears when travelling through a level crossing. If you make an error changing gears or if your vehicle stalls, it could prove disastrous. The risk is greater still for buses, where the driver is also responsible for safety of the passengers. Bus drivers and drivers of vehicles carrying dangerous substances are subject to special rules at level crossings. See Chapters 7 and 8 for information on these rules.

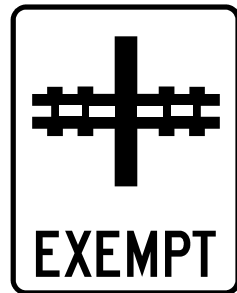

Truck drivers must take special precautions when they see a warning sign of the type illustrated opposite. It means that because of the configuration of the level crossing ahead, you must reduce your speed by more than 70% of the posted speed limit. For example, if the posted speed limit is 70 km/h, you must reduce your speed to no more than 20 km/h before crossing the railroad tracks.



# SELF-EVALUATION EXERCISES



## Theoretical Exercises

### True or false

---

1. Indicate whether the following statements are true or false.

	True	False
1. Looking far ahead of you is really essential only when driving on a highway.	<input type="checkbox"/>	<input type="checkbox"/>
2. You are driving a heavy vehicle 18 m long. To maintain a safe following distance, you need to count out an interval of 6 seconds between you and the vehicle you are following.	<input type="checkbox"/>	<input type="checkbox"/>
3. Before starting down a 10% grade, you should reduce your vehicle's speed by 10%.	<input type="checkbox"/>	<input type="checkbox"/>
4. You should avoid braking when going around a curve to avoid the risk of skidding.	<input type="checkbox"/>	<input type="checkbox"/>
5. To use air brakes effectively, you should press and release the brake pedal several times rapidly.	<input type="checkbox"/>	<input type="checkbox"/>

Answers at the end of the guide.



# **COPING WITH DANGEROUS SITUATIONS**

**6**

---

From time to time, you will be faced with dangerous driving situations. When this happens, the best course is to remain calm. These are the times when you will need to rely on your driving skills and knowledge to help you react quickly and effectively. This chapter provides advice to help you cope with certain problems or—better still—prevent them.

# WHAT SHOULD YOU DO WHEN YOU GET A FLAT TIRE?

While travelling, you may have a tire blowout or notice that one of your tires is leaking air. The impact of a flat tire differs depending on whether your vehicle is equipped with dual or single wheels and where the tire is located.

## Flat tire: rear tire on a dual-wheeled vehicle

A flat tire on a dual-wheeled semi-trailer may have very little impact on your driving, since the vehicle still maintains its stability. However, the extra weight on the other wheel may damage it. If you have a blowout on one of the tractor's rear tires, it may cause the rear end of the tractor to vibrate.

Often the best way to determine whether you have a flat tire, other than noise or vibration, is to pull over and check for yourself. If you have a flat, you must cease operating your vehicle until the tire is repaired or replaced.

## Flat tire: front tire, or rear tire on a single-wheeled vehicle (wide-tread)

A flat in one of the front tires, or in one of the rear tires on a single-wheeled vehicle, can often cause you to lose control of your vehicle. When one of your front tires goes flat, the vehicle tends to veer towards the side where the damaged tire is located. If the flat is a rear tire, the vehicle usually becomes unstable. You will have to adjust the way you drive to compensate for the imbalance to bring the vehicle to a safe stop.

To maintain control of your vehicle:

1. Grip the steering wheel firmly so that you can steer your vehicle out of the traffic lane.
2. Slowly ease off the accelerator and gradually apply the brakes to bring your vehicle to a stop in a safe location.

It is natural to want to stop your vehicle immediately when a flat occurs, but instead of slamming on the brakes, you must maintain speed and concentrate on easing off the road as you gradually reduce your speed.

# WHAT IS HYDROPLANING AND HOW SHOULD YOU REACT? 6

Hydroplaning occurs when vehicle tires lose traction, particularly when puddles form on the road surface due to rain. A thin layer of water then forms between the tire and the road surface, causing the tires to lose their grip on the road. Hydroplaning can be even worse if your tires are underinflated or the tread is worn.

## What should you do?

To maintain control of your vehicle:

1. Take your foot off the accelerator.
2. Avoid braking, since this could cause you to lose control of your vehicle. Once you have regained control of your vehicle, resume normal speed.

# WHAT CAUSES SKIDDING?

Most of the time, skidding is caused by travelling too fast on damaged, slippery or snow-covered road surfaces. When this happens, the tires lose their traction and tend to skid. This can happen if you brake too abruptly, if you take a curve too quickly, or if you are driving up or down a hill.

## Braking abruptly

Braking can sometimes cause your wheels to lock up and send your vehicle into a skid. When the wheels of a vehicle not equipped with an ABS brake system are locked, traction is reduced and tires skid, so that your vehicle requires a greater stopping distance. You must adjust your driving to maintain control of your vehicle.



## Driving up or down a hill

You may go into a skid when travelling up or down a hill if the force of acceleration is greater than the traction between your tires and the pavement. This is most likely to happen when the pavement is slippery or if you are travelling too fast for the condition of the road surface. If travelling up a hill, the wheels spin in place and the rear end of the vehicle veers to the side.



If travelling down a hill, the risk of skidding is greater still if the pavement is slippery or if you try to brake to slow down your vehicle. It is essential for you to apply the techniques for driving up and down hills explained above in Chapter 5 and in the section below.

## How to avoid skidding

It is very hard to regain control of a heavy vehicle once it goes into a skid. The best approach is to drive defensively and try to avoid skidding.

### WAYS TO AVOID SKIDDING

- ▶ Reduce your speed as dictated by road conditions and layout.
- ▶ Maintain a sufficient distance between your vehicle and other road users, especially when the pavement is slippery. This will help you avoid having to brake abruptly, which is one of the most frequent causes of skidding.
- ▶ Check your semi-trailer in the rearview mirrors every time you brake. Let up on your brakes if the semi-trailer is starting to skid.
- ▶ Do not use the hand brake to slow down your vehicle.

# HOW TO RECOVER FROM A SKID

In situations where defensive driving is not enough to avoid skidding, the first thing to do is determine the cause of the skid.

**If the skid is caused by overbraking:**

- ▶ Let up on the brake pedal so that your wheels start turning again and the tires can grip the pavement.

**If the skid is caused by rapid downshifting:**

- ▶ Press down on the clutch.

**IMPORTANT:** Use the brake pedal as needed. Once you have recovered control of your vehicle, shift into the appropriate gear.

**If the skid is caused by overaccelerating:**

- ▶ Slowly release the accelerator in order to regain control of your vehicle.

**IMPORTANT:** Change gears as needed to keep your wheels from spinning, while bearing in mind the effects of compression by the engine and the supplemental brakes.



## Maintain steering control

Whether a skid is caused by braking abruptly, accelerating quickly or a loss of traction in a curve, the rear end of the vehicle will veer to the left or to the right. To stop your vehicle from skidding completely out of control, you must turn your steering wheel in the same direction your vehicle is skidding.

If the rear end of the vehicle is skidding to the left:

1. Turn the steering wheel to the left to pull the vehicle back into a straight line.
2. When the vehicle is almost back in line, turn the steering wheel to the right until the front wheels are lined up straight.

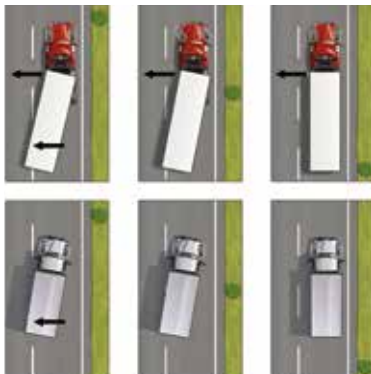

If the rear end of the vehicle is skidding to the right:

1. Turn the steering wheel to the right to pull the vehicle back into a straight line.
2. When the vehicle is almost back in line, turn the steering wheel to the left until the front wheels are lined up straight.

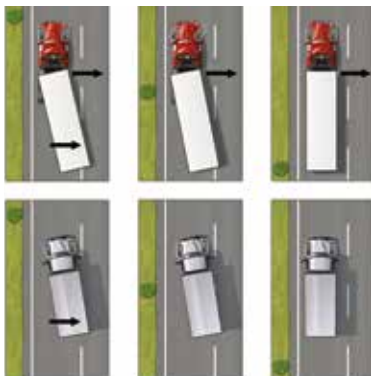

# WHAT CAUSES JACKKNIFING?



Jackknifing is caused when the forward thrust of the semi-trailer pushes the tractor over to the left or to the right. The tractor and semi-trailer are said to have jackknifed if they wind up positioned at an angle of less than 90°.

If you notice that you are losing traction, you must quickly let up on the accelerator or the brake pedal, as applicable, to avoid jackknifing.

# HOW TO MAKE AN EMERGENCY STOP

Any driver can be confronted by unexpected hazards. Whether you are driving a tractor-trailer, straight-body truck or bus, you must slow down as soon as you notice any of the following potential hazards:

- ▶ A vehicle up ahead is braking for no apparent reason.
- ▶ There are vehicles making frequent stops (delivery trucks, taxis, buses).
- ▶ There are vehicles parked by the side of the road.
- ▶ The road is slippery.
- ▶ Your field of vision is blocked.

But even if you drive proactively, situations can arise that force you to brake abruptly. When this happens, you must be able to maintain your vehicle in a straight line, stay on course and make a turn if you need to. Be extra cautious when braking with a loaded vehicle.

Today, most heavy vehicles are equipped with an anti-lock brake system (ABS) that prevents the wheels from locking if the brakes are applied abruptly. However, circumstances may require you to drive a vehicle not equipped with an ABS system. If so, you must be able to use the proper technique to make an emergency stop without causing the wheels to lock up, as explained below:

1. Press down on the brake pedal as soon as the situation requires.
2. Gradually increase pressure on the brake pedal, as far as you can without causing your wheels to lock up, until you bring your vehicle to a complete stop.

If you see that your wheels are locking up, let up on the brake pedal slightly to keep from losing control of your vehicle. Resume pressure on the brake as soon as the wheels start turning again, making sure that the wheels do not lock up.

# IF YOUR BRAKES SHOULD FAIL DESPITE ALL YOUR EFFORTS

You have to apply your brakes very often while driving. How well they perform depends on the condition they are in and how you use them. Your brakes may perform poorly or fail due to:

- ▶ a loss of air pressure or leakage of brake fluid;
- ▶ mechanical failure by the wheels;
- ▶ overheating;
- ▶ wear;
- ▶ improper adjustment.

You should also monitor the pressure gauge frequently to be sure you have enough air pressure to operate the brakes.

**Prevention** is the best way to minimize the risk of mechanical failure. See Chapter 12 for information about **circle checks**.

---

Drive proactively to minimize braking and use proper braking techniques—these are the best ways to avoid failure of your brake system.

---

## How to bring your vehicle to a stop

# 6

The technique to use for stopping your vehicle depends of the kind of brake system you have.

### Vehicle with hydraulic brakes

1. Pump the brake pedal (quick repeated strokes) to generate pressure in the brake lines so that you can stop your vehicle.
2. Downshift.
3. Apply the parking brake (which also serves as the emergency brake in most hydraulic systems) if you are unable to generate enough pressure in the lines. Try not to cause your wheels to lock up.
4. Look for a place where you can stop without endangering other road users.
5. Make sure that your vehicle is completely stationary once you have come to a stop.
6. Switch off the engine.

## Vehicle with air brakes

### IMPORTANT

If the low-pressure warning light comes on (usually along with a buzzer) or if the pressure gauge warns you of a drop in pressure, this means that there is not enough air pressure to work the service brakes properly. When this happens, even if your emergency brake takes over to bring you to a gradual stop, you must stop as quickly as you can because it will soon become impossible to use the service brakes.

1. Apply the brakes to slow the vehicle down gradually, but without pumping the brake pedal.
2. Downshift.
3. Look for a place where you can stop without endangering other road users.
4. Make sure that your vehicle is completely stationary once you have come to a stop.
5. Switch off the engine.

### If your brakes fail while driving down a hill

Brakes are designed to withstand a certain amount of heat, but if you apply them too often or for too long at a time, they can overheat.

Before starting down a steep grade, make sure that your brakes are in good condition. If you are not sure, pull over and check them.

If, despite all of these precautions, you realize that your brakes are not working properly, you will have to find a way of slowing down and stopping your vehicle quickly without losing control of it. Time is of the essence here because the greater your speed, the harder it will be to stop your vehicle.

If there is no runaway lane with an arrester bed, steer towards a spot where you can stop your vehicle safely. You must find an appropriate place to pull over as quickly as possible.

If there is a runaway lane with an arrester bed, use it. It will enable you to safely bring your vehicle to a complete stop.

Before starting down a hill, you can tell whether there is a runaway lane up ahead. First you will see a LIT D'ARRÊT sign indicating the distance until the runaway lane with its arrester bed, and then an S.O.S. PENTE RAIDE sign indicating you are arriving at the top of an especially steep grade. If your brakes fail, follow the instructions provided by these signs. They will guide you to the runaway lane.



# IF YOUR VEHICLE CATCHES FIRE

To avoid a fire, which could cause serious damage or injury, there are a number of preventive measures you should take before beginning a trip and at each stop along the way. See Chapter 12 for information on circle checks.

You should check temperature readings continuously and use your rearview mirrors to check for smoke coming from the rear of your vehicle.

## What to do in the event of an emergency

If a fire breaks out, the first thing to do is find a place at some distance from buildings and other vehicles where you can pull off the road. Switch off the engine and move away from your vehicle if there is a credible risk of explosion. Stop traffic and direct any people in the vicinity away from your vehicle.

Then call for assistance.

Once you have done all this, take the following steps, if it is possible for you to do so. The order in which you perform these tasks may vary depending on what type of fire you are dealing with and where it is located in the vehicle:

1. Unhitch your semi-trailer and move the tractor away from it.
2. Switch off the engine if you have not already done so.
3. Use a fire extinguisher, if possible.

If the fire you are attempting to extinguish is in the engine compartment, raise the hood. Most important of all, **do not use water** to put out a fire that is being fed by fuel.

Be careful using a fire extinguisher and keep your back to the wind.



# IF AN ANIMAL STRAYS ONTO THE ROAD

Road signs are used in wooded areas to warn that there might be wildlife in the vicinity. Wildlife can venture onto the road, interfere with traffic and sometimes cause serious accidents. Be on guard at all times, especially at night, because animals are attracted by headlights.



In a high-risk area, stay alert:

- ▶ Obey the speed limits.
- ▶ Be extra careful in areas of reduced visibility due to a bend in the road, a hill or heavy vegetation by the roadside.
- ▶ Be extra careful in the early morning, at dusk and in the evening, particularly during the months of May, June, October and November.

If an animal is on the road:

- ▶ Slow down and press your brakes several times to alert motorists behind you.
- ▶ Be alert in case there are other animals in the vicinity.
- ▶ Do not rely on gadgets such as deer whistles. They have not been proven effective.

# SELF-EVALUATION EXERCISES



## Theoretical Exercises

### True or false

---

1. Indicate whether the following statements are true or false.

	True	False
1. With hydroplaning, the way to maintain control of your vehicle is to apply the brakes.	<input type="checkbox"/>	<input type="checkbox"/>
2. If a blowout occurs in one of the dual wheels on a semi-trailer, the driver will feel the impact strongly.	<input type="checkbox"/>	<input type="checkbox"/>
3. If your vehicle begins to skid, you should turn your steering wheel in the same direction as the skid to avoid skidding completely out of control.	<input type="checkbox"/>	<input type="checkbox"/>
4. Hydraulic brakes are designed in such a way that overheating does not affect how well they perform.	<input type="checkbox"/>	<input type="checkbox"/>
5. Your emergency brakes take over when there is not enough compressed air in the reservoirs of the air brake system.	<input type="checkbox"/>	<input type="checkbox"/>

Answers at the end of the guide.

# TRANSPORTATION OF PASSENGERS

7

---

Bus drivers bear a number of responsibilities with respect to their passengers' safety. Before allowing passengers on board any bus you are driving, you must make sure that it complies with all safety standards that fall under your responsibility. You also have to obey certain rules when picking up and dropping off passengers and throughout the trip.

If you are a school bus driver, this chapter also contains information intended specifically for you.

# LAWS AND REGULATIONS 7

Drivers who carry passengers must be familiar with the applicable laws and regulations to perform their work properly. The principal bodies responsible for enforcing these laws and regulations are the Société de l'assurance automobile du Québec, the Ministère des Transports du Québec and the Commission des transports du Québec.

In addition to the *Highway Safety Code*, which applies to all drivers, professional drivers carrying passengers are subject to other laws and regulations governing this form of transportation, including the following:

▶ **Transport Act**

This law specifies the powers and functions of the Commission des transports. It also establishes requirements for school bus drivers, including the requirement to hold a certificate of competency, and determines which bodies may provide such training.

▶ **Bus Transport Regulation**

This regulation governs the issuing of permits for transporting passengers by bus.

▶ **Regulation respecting road vehicles used for the transportation of school children**

This regulation sets standards for the manufacturing, outfitting and use of school buses.

► **Regulation respecting the hours of driving and rest of heavy vehicle drivers**

All bus drivers other than those employed in urban transit are governed by this regulation. In addition to Québec regulations, they must also obey the regulations in force in other jurisdictions when travelling outside Québec.

► **Regulation respecting safety standards for road vehicles**

This regulation requires that a bus driver must perform a circle check within 24 hours before taking a bus out on the road, or must read the report of the previous circle check and sign it, provided the check was done within the preceding 24 hours. If the owner or operator designated a person other than the driver to do the circle check, the driver must read the report completed by the designated person and sign it. See Chapter 12 for more information regarding the enforcement of this regulation.

## NUMBER OF PASSENGERS

The *Highway Safety Code* determines the maximum number of passengers allowed on a bus.

For buses used to carry school children, the number of passengers allowed corresponds to the number of seating positions. When driving a school bus, you may not allow more than three school children on one seat. There must be sufficient space for each child so that he or she can be seated safely and without blocking the aisle.

For buses not used to carry school children, the following rules apply:

- ▶ For buses travelling outside an urban area (such as chartered), the maximum number of passengers allowed corresponds to the number of seating positions, plus one place for a standing passenger for each row of seats. For example, on a bus with 15 rows of seats, you may allow no more than 15 passengers standing in the aisle.
- ▶ For buses travelling in an urban area (such as mass transit buses), the Code sets no limit on the number of passengers allowed on board.

## RULES FOR THE ROAD

### Picking up and dropping off passengers

Before picking up or dropping off passengers, you must pull over and come to a full stop on the far right-hand side of the road or in a special area designated for that purpose. Once you have stopped, you may not open your door until you have made sure that it is safe to do so.



## While driving

You should drive smoothly to ensure that your passengers are as comfortable as they have a right to expect and to avoid collisions and injuries. This is especially important when starting, stopping and turning, or when the road is bumpy.

There are various traffic rules bus drivers must obey to protect the safety of their passengers and other road users. For example:

- ▶ You may not drive on after stopping if anyone is leaning against the outside of the bus (the bumper, for example).
- ▶ Before driving on, you must make sure that none of the passengers you have just dropped off is at risk of being struck by the bus or getting caught underneath it.
- ▶ On roads within city limits where the posted speed limit is under 70 km/h, a bus has the right of way when pulling back into the lane it was using before it stopped. Nevertheless, you must use good judgment at all times and make sure you can pull back into your lane without endangering other road users. This means that before pulling away from the curb, you must make sure the way is clear and click on your turn signal lights.
- ▶ At level crossings, you must slow down and make sure you can stop without endangering other road users. You must stop your vehicle at least 5 m from the crossing, and you may not proceed until there is enough room between you and any vehicle ahead of your bus for you to clear the crossing completely, regardless of any traffic lights. You are exempted from this obligation only if there is an EXEMPT sign posted.





- ▶ Even though buses are subject to mechanical inspection rules, you do not have to stop at inspection stations, unless the bus is hauling a trailer.
- ▶ When driving any vehicle with a total loaded mass of 3,000 kg or more, including a bus, you must pull over when you come to a brake check area designated by a VÉRIFICATION sign. You must come to a full stop at the stop sign and check the brakes yourself. As a complementary measure, we recommend that you also follow the brake inspection procedure outlined in Chapter 12.

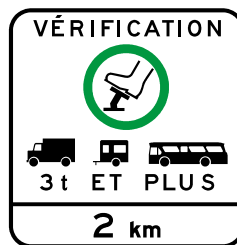
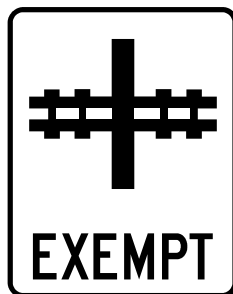

## Driving on the shoulder

It is permitted to drive on the shoulder of a highway or another controlled access road if all of the following conditions are met:

- ▶ The driver took the required training course;
- ▶ The signage authorizes travel on that highway or road;
- ▶ The speed of traffic on the highway is under 50 km/h.

# SCHOOL BUSES

The above rules apply to most types of buses, but there are additional rules that apply specifically to drivers of school buses. These rules are outlined below.

## Driver training

As a school bus driver, you play an essential part in safeguarding your young passengers. Your task is a demanding one: you must remain patient and vigilant at all times. Driving a school bus full of often boisterous children and making sure they are safe can be a challenge. This is why school bus drivers must receive training in the special skills their job requires.

A special school bus driver training course has been developed to meet this need. School bus and minibus drivers are required to have a certificate of competency issued by one of the two existing road transport training centres, in addition to a driver's licence of the appropriate class.

 To learn more, visit the website of the Société de l'assurance automobile du Québec ([saaq.gouv.qc.ca](http://saaq.gouv.qc.ca)).

To obtain this certificate, drivers have to pass a 15-hour training course (*Basic training program for school bus drivers*) dealing with the role and responsibilities of school bus drivers, rules relating to safety equipment, techniques for picking up and dropping off school children, and emergency response. They must also renew their certificate every 3 years after completing 6 hours of supplementary training.

Experienced drivers must be able to adjust to unforeseen circumstances. They must show tact and initiative in settling disputes and dealing with unruly youngsters. They also need to know something about the behaviour of the school children they carry.

Finally, drivers should be very familiar with the rules of the *Highway Safety Code* and with school board transportation policy.

## Picking up and dropping off school children

## 7

When picking up or dropping off children, school bus drivers must first slow down and move over to the right side of the lane or, where applicable, the parking area.



Then (unless you are driving a vehicle that carries wheelchair passengers exclusively), there are two phases involved in bringing the bus to a stop:

1. Switch on the alternately flashing yellow warning lights to alert other motorists or cyclists that the bus is about to stop. (School buses built before August 29, 2005 are not equipped with alternately flashing yellow warning lights and are exempt from this requirement, but the hazard lights must be switched on).
2. Switch on the flashing red lights and activate the mandatory stop sign. You may not pick up or drop off school children unless the flashing red lights are switched on.

You must also switch on your flashing lights and stop sign if you are parked behind another school bus whose flashing lights are on, even if you are not dropping off or picking up schoolchildren.

You may not use your flashing lights or stop sign in any other circumstances.

## While driving

You may not drive on after stopping until you are sure that all of your passengers are seated and the bus door is closed. In addition, you may never leave your school bus if there are passengers still on board unless absolutely necessary.

## Mandatory equipment

You are responsible for making sure that your school bus is equipped with the following:

- ▶ three reflective warning triangles;
- ▶ one dry-chemical fire extinguisher installed inside the bus near the front door and properly secured in a box within reach of the driver;
- ▶ one complete first-aid kit solidly installed within reach of the driver. The contents of the kit are prescribed by regulation.

If you are using a school bus to carry school children or passengers under 18 years of age, you must make sure your vehicle is equipped with an ÉCOLIERS sign at the front and the back. If you are using a school bus to carry passengers age 18 or older, you must remove or cover up these signs.

# SECURING BAGGAGE

# 7

It is prohibited to carry any item weighing over 50 kg and having a volume of more than 0.450 m<sup>3</sup> inside a motor coach.

The passengers' baggage must be distributed and secured in such a way that it cannot move around freely during the trip. If baggage comes loose, it may cause injury to passengers or distract the driver.

Motor coach drivers who carry packages and baggage in addition to passengers must stow these items in the compartments designed for that purpose.



# SELF-EVALUATION EXERCISES



## Theoretical Exercises

### True or false

---

1. Indicate whether the following statements are true or false.

	True	False
1. If you drive a school bus with 12 rows of seats, you can accept up to 12 standing passengers.	<input type="checkbox"/>	<input type="checkbox"/>
2. Drivers of buses with a total loaded mass of 3,000 kg or more must stop where a VÉRIFICATION sign calls for the brakes to be checked.	<input type="checkbox"/>	<input type="checkbox"/>
3. If you drive a bus, you must stop your vehicle at least 3 m from a level crossing.	<input type="checkbox"/>	<input type="checkbox"/>
4. It is prohibited to pick up or drop off school children with a school bus if the flashing red lights are not switched on.	<input type="checkbox"/>	<input type="checkbox"/>
5. If you have to stop your school bus behind another school bus that has its flashing lights on, you must switch your flashing lights on as well.	<input type="checkbox"/>	<input type="checkbox"/>

Answers at the end of the guide.

# TRUCKING

8

---

This chapter provides general information you need to work in the carrier industry, in particular information relating to:

- ▶ vehicle load and size limits;
- ▶ the principal cargo securement standards;
- ▶ the transportation of dangerous substances;
- ▶ environmental standards for heavy vehicles.

In addition to delivering the goods they are carrying to the right place, drivers must obey road safety rules and statutory requirements that govern this type of transportation.

Sometimes, depending on the type of transportation, you may be in charge of loading and unloading the goods you carry. In such cases, you must ensure that the weight of goods is distributed correctly and that the cargo is properly secured.

You must also adjust your manner of driving to the type of vehicle you are using and the type of cargo you are carrying. For example, driving a tank truck with liquid cargo that is mobile is quite different from carrying stationary cargo such as lumber. You must take into account the weight of the load you are carrying, the load's centre of gravity and the length of the load, which sometimes exceeds the length of the vehicle.

You must therefore adjust your driving as dictated by these factors. By exercising caution and employing the suggested techniques, you will develop the skills and habits of a real professional.



# LOAD RESTRICTIONS

# 8

## Protecting the road network

Every year, all sorts of vehicles carrying all sorts of loads use the road network. Since costs for repair and improvement of Québec roads can run into millions of dollars, the need for rules and regulations restricting vehicle loads is obvious.

Exceeding the load limits prescribed by regulations or by the manufacturer can also cause serious damage to key vehicle components, such as brakes, tires, suspension and coupling device. These components are designed to support a specific maximum load. Exceeding that limit will cause them to wear out prematurely.

## Vehicle load and size limits

The main purpose of the *Vehicle Load and Size Limits Regulation* is to ensure the safety of road users and protect infrastructures such as roadways and bridges. The Regulation sets standards limiting load size, load per axle group and total loaded mass of trucks travelling on public roads, based on the classes defined in the Regulation.

The methods for determining authorized heavy vehicle load and size limits are described below. For complete information, refer to the Regulation or consult the *Vehicle Load and Size Limits Guide* available from the Ministère des Transports du Québec.

## Load per axle

The maximum load authorized for an axle class is the lowest of the following three values:

- ▶ the total capacity of all tires in the same axle class.  
The manufacturer indicates this capacity on the sidewall of the tire;
- ▶ the front-axle capacity. The capacity is 5,500 kg for a front single axle (class B.1) and 11,000 kg for a front tandem axle (class B.2) or front multiple axle (class B.3).  
The front-axle capacity may be greater if so indicated by the vehicle manufacturer or by a vehicle modifier that has made alterations to a vehicle with authorization from the Société de l'assurance automobile du Québec;
- ▶ the load limit of the axle class, depending on the time of year (normal period or spring thaw).

## Total loaded mass

The authorized total loaded mass for a truck or a vehicle combination is the lower of the following two values:

- ▶ the sum of the maximum loads authorized for each axle class of a vehicle or vehicle combination, depending on the time of year (normal period or spring thaw);
- ▶ the total loaded mass limit for the class of vehicle or vehicle combination.

## Dimensions

In general, the authorized maximum dimensions for each category of vehicle, including the load, are as follows:

### Length

Truck

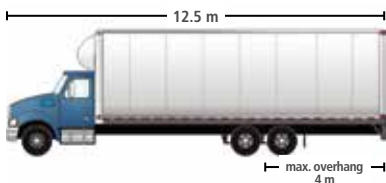

### Height



### Width



Bus

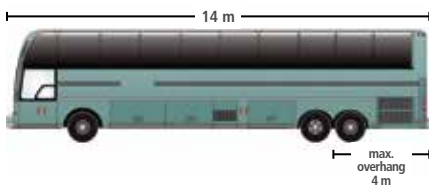

Truck and trailer

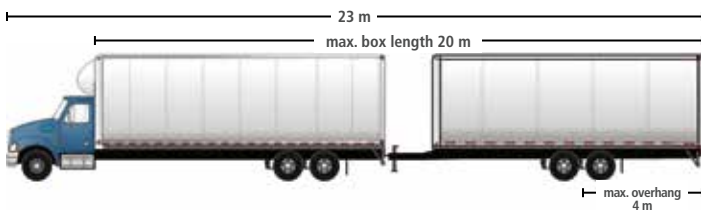

Tractor and semi-trailer\*

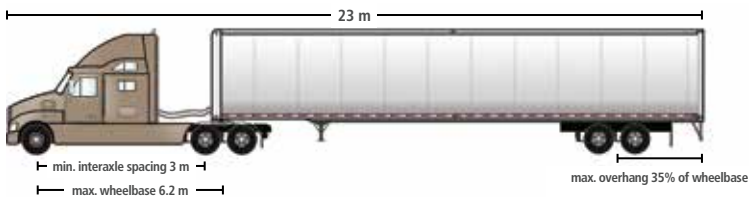

Type B double train

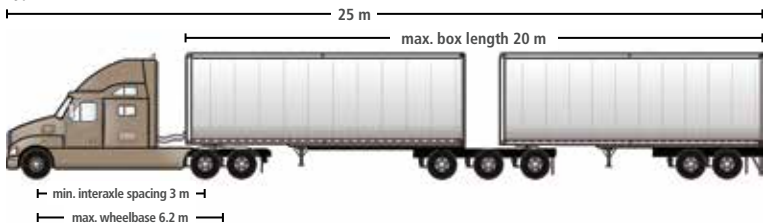

## Trailers and semi-trailers

Trailer with a dolly

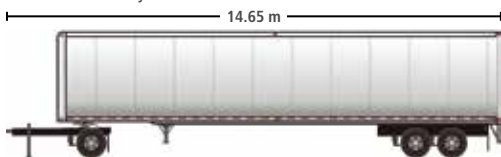

Trailer without a dolly

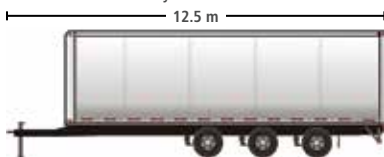

Semi-trailer

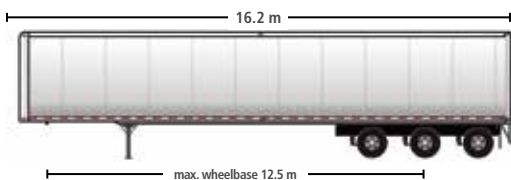

\* Maximum of 35% (including load) of the distance between the centre of the single, tandem or tripe axle and the centre of the kingpin.

# SPECIAL TRAVEL PERMITS 8

Some road transport vehicles are subject to specific regulations because their size or load exceeds the limits allowed under the *Vehicle Load and Size Limits Regulation*. These vehicles are considered outsized or overloaded and the owner or operator must obtain a special travel permit.

▶ **Class 1 to 7 special travel permit**

A permit issued under the *Regulation respecting special permits*, which prescribes the conditions a vehicle must meet if it is outsized or overloaded due to its characteristics or because its load is indivisible.

▶ **633 permit**

A permit issued in exceptional circumstances, essentially for the purpose of allowing travel by experimental vehicles. The 633 permit serves to harmonize Québec's standards with those of other jurisdictions.

This permit authorizes the operation of a vehicle combination that has become outsized by reason of one of the following situations:

- ▷ The semi-trailer(s) is or are equipped with at least one lift axle.
- ▷ The tractor/semi-trailer is carrying a fork lift at the rear.
- ▷ The tractor's wheelbase is greater than 6.2 m.
- ▷ The length of the type B double train is more than 25 m.
- ▷ The combination of vehicles is carrying automobiles.
- ▷ The tractor is equipped with three axles at the rear.

▶ **Special road train operating permit**

A permit issued under the *Special Road Train Operating Permits Regulation*. For more information on driving a road train, refer to Chapter 10.



For more information on special permits, visit the website of the Ministère des Transports du Québec ([www.transports.gouv.qc.ca](http://www.transports.gouv.qc.ca)).

# SAFEGUARDING BRIDGES AND OVERPASSES

It is very important to respect load limits for bridges and overpasses. Two types of road signs warn drivers of the load limit a bridge or overpass is able to support.

A restricted weight sign placed near a bridge or overpass indicates that buses or trucks<sup>2</sup> with a total loaded mass in excess of the maximum posted on the sign are not allowed to use the bridge or overpass.



A restricted weight sign that is accompanied by a tab may also be placed at an intersection preceding a bridge or overpass. It indicates the direction and the distance to the bridge or overpass. This type of warning allows the driver to choose an alternate route and avoid the weight restriction.



A restricted weight sign may also be located at the approach to a bridge or overpass with a UN VÉHICULE À LA FOIS tab. In addition to a weight limit, no more than one vehicle at a time may cross the bridge or overpass. This means that the structure cannot support more than one heavy vehicle at a time, even if the heavy vehicle's total loaded mass is under the posted limit.



<sup>2</sup> This sign also applies to tow trucks, tool vehicles and equipment transport vehicles.

A weight restricted to legal load limits sign means that a heavy vehicle cannot be driven across a bridge or overpass if its weight exceeds the legal limit prescribed by the *Vehicle Load and Size Limits Regulation*.



To be authorized to drive across a bridge or an overpass with a vehicle exceeding the posted weight limit or legal load limitation, the driver must hold a special travel permit issued specifically for that purpose. For additional information, contact the Ministère des Transports du Québec at 1 888 355-0511.

 For information about weight limits on bridges and overpasses, refer to the list on the website of the Ministère des Transports du Québec ([www.transports.gouv.qc.ca](http://www.transports.gouv.qc.ca)).

# RULES FOR SECURING CARGO

Under the *Highway Safety Code*, a vehicle's load must be:

- ▶ properly secured or covered so that it cannot shift around or be dislodged from the vehicle;
- ▶ placed so as not to obstruct the driver's view, interfere with the vehicle's stability or handling, or block its lights;
- ▶ secured in compliance with the requirements of the *Cargo Securement Standards Regulation*.

The *Cargo Securement Standards Regulation* of the Ministère des Transports du Québec integrates the provisions of National Safety Code Standard 10, Cargo Securement, which applies throughout North America. It establishes the minimum requirements for securement systems and their use based on the type of vehicle used and the type of cargo transported. The objective is to prevent the cargo from shifting or tipping and ensure the vehicle's stability on the road.\*

---

\*For more information on this subject, we suggest you read the *Cargo Securement Guide*, published by the Ministère des Transports du Québec ([www.transports.gouv.qc.ca](http://www.transports.gouv.qc.ca)).

---



# GENERAL RULES

The *Cargo Securement Standards Regulation* spells out the general standards that apply to all types of cargo for road vehicles with a gross vehicle weight rating (GVWR) of 4,500 kg or more. If they meet certain conditions, farm tractors and bulk cargo transported in sided vehicles are generally exempt. The Regulation also provides for certain standards specifically for bulk cargo such as earth, sand, gravel, salt, bituminous concrete, road demolition waste, snow and ice.

The general standards prescribe that cargo must be firmly secured or immobilized inside the vehicle transporting it. To ensure that the cargo remains immobilized during transportation, the tiedown system must meet performance criteria in order to counteract the forces (front, rear, lateral and vertical) applied to the cargo as a result of the driver's manoeuvres, road geometry, road surface conditions and wind.

The cargo may be secured or immobilized by structures of adequate strength, blocking systems, bracing, dunnage or dunnage bags, shoring bars, tiedowns, friction mats or a combination of these.

Their use must be appropriate to the dimensions, shape and resistance of the cargo and all of their components must be in proper working order, appropriate to their use and show no damage that could hamper their performance.

Drivers are required to check the cargo and the tiedown system and make the appropriate adjustments before setting out and at various moments thereafter. Note that drivers are not required to inspect the cargo if it is inaccessible or sealed in a vehicle and they have received instructions not to open the vehicle.

Cargo securement requires the use of a minimum number of tiedown devices. This number is generally established on the basis of the devices' resistance as well as the mass and length of the cargo to be immobilized. Their use must generally comply with the following rules:

- ▶ **Where an article is blocked or immobilized** by a front end structure, a bulkhead, another article of cargo that has been immobilized or another device to prevent it from shifting forward, it must be secured in the following manner, regardless of its mass:

#### Article no longer than 3.04 m

Use at least one tiedown.

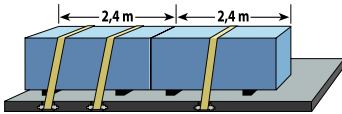
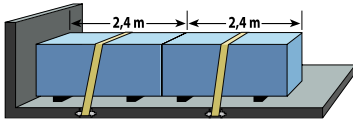

#### Article longer than 3.04 m

Use one tiedown for the first 3.04 m of length and an additional tiedown for each additional 3.04 m of length or fraction thereof.

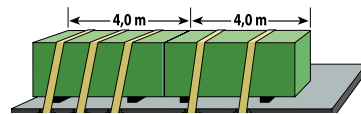
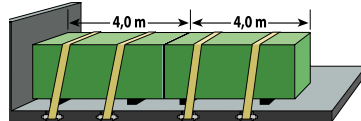

- ▶ **Where an article of cargo is not blocked or immobilized** by a front end structure, a blocking system or another article of cargo that has been properly secured, at least one tiedown device is required for an article with a mass of no more than 500 kg and a length of no more than 1.52 m. For an article of the same length but with a mass above 500 kg, at least two tiedown devices are required. However, regardless of mass:

### Article no longer than 3.04 m

Any article longer than 1.52 m and no longer than 3.04 m requires at least two tiedown devices.

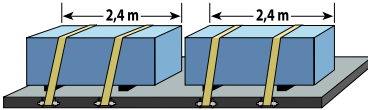

### Article longer than 3.04 m

Articles longer than 3.04 m require two tiedown devices for the first 3.04 m and one additional tiedown device for each additional length of 3.04 m or fraction thereof.

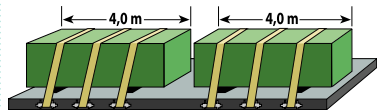

- ▶ All tiedowns (straps, chains, etc.) used in accordance with the *Cargo Securement Standards Regulation* must bear the manufacturer's certification with regard to its Working Load Limit (WLL). The WLL is the maximum load assigned by the manufacturer that can be applied to the tiedown device or system under normal use.



Strap certified by the manufacturer



Uncertified strap

- ▶ The sum of all tiedown WLLs used to secure an article or a group of articles on a vehicle is the total WLL. The total WLL of the tiedowns used in a tiedown system cannot be less than 50% of the cargo's total mass that is secured by this system. For example, for a cargo with a mass of 2,268 kg, the tiedown system must have a capacity of 1,134 kg or more.

If cargo is transported inside of a **closed vehicle**, it must be distributed so as to cover all of the space available inside the vehicle. Articles must be immobilized by direct contact with the walls of the vehicle or with other articles of cargo. If the type of goods being carried cannot be distributed to cover the entire space inside the vehicle, immobilization devices can be used, for example, blocking systems, bracings, dunnage or dunnage bags, shoring bars, tiedowns or a combination of these.



Sided vehicle

For goods that are transported on a flatbed vehicle, tiedowns must be used to properly secure all articles of cargo to the vehicle.

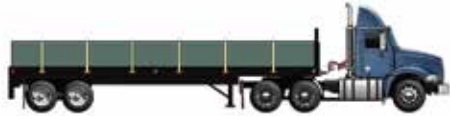

Flatbed vehicle

If the cargo or any article of cargo is in danger of shifting around during transport, it must be immobilized with chocks, wedges, cradles or other securement devices.

# SPECIAL RULES FOR THE SECUREMENT OF CERTAIN TYPES OF CARGO

To prevent articles from becoming dislodged, you must know how to properly secure cargo and comply with the special rules that apply to each type of load you are carrying. These rules were established to accommodate the specific type of articles contained in the load.

Given the wide variety of types of cargoes and cargo securement methods available, the following pages focus solely on certain general characteristics of the different types of cargoes for which special securement rules have been established.\*

---

\*For more information on the way to secure each type of cargo, refer to the Cargo Securement Standards Regulation or the website of the Ministère des Transports du Québec at [www.transports.gouv.qc.ca](http://www.transports.gouv.qc.ca).

---

## Logs



The term “log” refers to a felled and clean-boled tree trunk or section of tree trunk, whether or not it has been stripped of its bark. It also includes public utility poles, butt-treated poles and poles used as construction material in roundwood buildings. In the case of tree trunks, logs are both cylindrical and tapered. Properly securing a cargo of logs requires a combination of tiedowns and blocking systems such as posts and bunks.

## Dressed lumber



The transportation of bundles of dressed lumber involves special securement issues. Such bundles are usually stacked on top of one another and secured by tiedowns spanning the top of the bundles. Stacking bundles makes for a higher centre of gravity and also reduces the effectiveness of the tiedowns, since it is difficult to install tiedowns on stacked bundles with uniform tension over all the articles secured.

To account for these special conditions, the Regulation prescribes special securement standards for a cargo of dressed lumber bundles stacked more than one layer high.

## Metal coils



A metal coil is a heavy cylindrical object. Whether loaded vertically or horizontally, their special features require you to use effective immobilization devices and a minimum number of tiedowns for each coil.

## Paper rolls

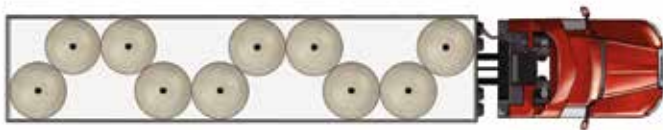

A paper roll is a heavy cylindrical object that is rather fragile due to the very nature of the product. Because of these characteristics, a cargo of paper rolls is usually transported inside a van or intermodal container, and the Regulation provides special rules to ensure that such loads are firmly immobilized or secured inside the vehicle.

Special securement standards are also prescribed for transport of paper rolls on flatbed vehicles where there are no sides to hold the cargo in place.

## Concrete pipes



A concrete pipe has a cylindrical shape and its outer texture has a high friction coefficient. Large-diameter pipes may be transported one per vehicle, but small-diameter pipes can be loaded several to a vehicle, braced against one another and stacked. However they are positioned, concrete pipes must be secured to prevent them from shifting or rolling around. The Regulation prescribes special securement standards for cargoes comprised of small- and large-diameter concrete pipes.

## Intermodal containers



An intermodal container is a metal box of standardized dimensions used to transport cargo. It is equipped with integrated locking devices so that it can be secured to a container chassis vehicle or flatbed vehicle. In view of their characteristics, the Regulation prescribes special securement standards for intermodal vehicles.



## Roll-on/roll-off containers (removable containers)



A roll-on/roll-off container is a specialized container that has integrated rollers enabling it to be loaded onto or unloaded from a tilt frame body by using a lifting device. This type of container is transported by vehicles specially adapted to secure the container at front and rear. The Regulation prescribes special securement standards for the types of containers transported on these types of adapted vehicles.

### Vehicles transported as cargo

#### Vehicle with an individual weight of 4,500 kg or less



A vehicle with an individual weight of 4,500 kg or less generally consists of moving mechanical parts that enable the vehicle to be driven. Some of these parts (tires, suspension, etc.) allow free vertical movements. Because of these characteristics, transport of such vehicles requires the use of special securement systems.

## Flattened or crushed vehicle with an individual weight of 4,500 kg or less



A flattened or crushed vehicle is a road vehicle that has been compressed mechanically to reduce its volume and facilitate its storage and transport. This process results in the crushing or dislocating of parts that are integral components of the vehicle. After being flattened or crushed, vehicles can then be stacked for transport. Components can become dislodged from the vehicles during transport when subjected to the external forces generated by a heavy vehicle in motion. In view of these characteristics, the Regulation prescribes special securement standards for the transport of such vehicles.

## Vehicle with an individual weight greater than 4,500 kg



A vehicle with an individual weight greater than 4,500 kg, just like a vehicle of lesser weight, is generally composed of moving parts that enable the vehicle to be driven. This category of vehicles also includes tracked machinery or equipment. Some of these mechanical parts (tires, suspension, etc.) allow free vertical movements. Because of these characteristics, transport of such vehicles requires the use of special securement systems.

## Boulders



A boulder is a large, irregularly shaped rock, naturally occurring or extracted from a quarry. The regulations concerning the securement of boulders concerns those with a mass above 5,000 kg or a volume above  $2\text{m}^3$ . Boulders with a mass above 100 kg and below 5,000 kg can also be secured in accordance with the same provisions.

Although its shape may be similar to that of other boulders, each boulder has its unique characteristics (shape, weight, etc.). In view of these characteristics, the Regulation contains special securement standards for the transport of boulders.

## Bulk cargo



The term “bulk” covers several classes of products (aggregates, liquids, gases, granular products, etc.) that are piled in for transport. Certain bulk cargoes are transported in a dump truck, a container or other type of receptacle whose upper part is totally or partially open. The Regulation prescribes special standards for covering bulk cargo carried in these types of receptacles.

# SECUREMENT INSPECTION

Under the Regulation, drivers must inspect the vehicle's cargo securement prior to departure and during the trip.

You must perform a visual inspection to ensure that the vehicle's tailgate, tailboard, doors, tarpaulins, spare tire, tire rack and other equipment used in operating the vehicle are secured. You must also ensure that the cargo:

- ▶ does not interfere with your ability to drive the vehicle safely;
- ▶ does not hinder a person from freely exiting your cab or driver's compartment.

## Inspection of cargo and the cargo securement system

You must also inspect the vehicle's cargo and the cargo securement system used to restrain the load. You must make any necessary adjustments:

- ▶ before driving the vehicle

and

- ▶ not more than 80 km from the point where the cargo was loaded onto the truck.

You must re-inspect the vehicle's cargo and the cargo securement system regularly. If necessary, you must also make any necessary adjustments, including adding more tiedowns. The cargo must be re-inspected when any of the following situations occurs:

- ▶ Your activities or duty status changes.
- ▶ The vehicle has been driven for 3 hours.
- ▶ The vehicle has travelled 240 km.

Under the Regulation, you are exempt from performing inspections of cargo and the cargo securement system only in the following situations:

- ▶ The cargo is sealed in a vehicle and the driver has been ordered not to open it to inspect the cargo.
- ▶ The vehicle is loaded in a manner that prevents access to the cargo or portions of the cargo.

## TIPS FOR PROPER LOAD DISTRIBUTION

Load distribution can affect your vehicle's stability and manoeuvrability. The weight of the load and the location of its centre of gravity can affect ease of handling. It is therefore essential to distribute the load so that its centre of gravity is as low as possible.

For easier vehicle handling and to ensure compliance with mandatory load limits, cargo should be loaded so that its weight is distributed as evenly as possible over each axle. Overloading the front axles, for example, can make steering difficult and damage the axles or tires.

Similarly, too much weight on the rear axles can reduce front wheel traction and make handling the vehicle harder.

### Load properly distributed



### Load not properly distributed



If there is not enough weight on the drive wheels, the vehicle can skid, especially on a slippery road surface. A load that is not properly distributed or secured is liable to shift around or be dislodged from the vehicle, which would displace the centre of gravity and jeopardize the stability of the vehicle and its load.

### LOADS OVERHANGING THE REAR OF THE VEHICLE

You must place a red flag or reflecting panel at the rear end of any load or equipment that overhangs the rear of the vehicle by more than one metre.

Also, if you are driving your vehicle with such a load at night, you must install a red light that can be seen from at least 150 metres to the rear and to the sides.

If the equipment or load cannot be arranged without overhanging the rear of the vehicle by more than two metres, you must obtain a special travel permit and comply with the special rules for this type of permit.

# RULES FOR TRANSPORTING DANGEROUS SUBSTANCES

## Regulations governing the transportation of dangerous substances

Anyone who handles and transports dangerous substances (or offers such substances for transportation) on Québec's public roads must comply with the *Transportation of Dangerous Substances Regulation* all the way from the manufacturing or distribution site to the delivery or unloading site. In some cases, the Regulation provides for exemptions, depending on the type or quantity of substances transported. It also includes, by reference, the standards prescribed by Transport Canada's *Transportation of Dangerous Goods Regulations*.

Since the *Transportation of Dangerous Substances Regulations* prescribes obligations and responsibilities for anyone who transports or handles dangerous substances (or offers such substances for transportation), this section lists the requirements that drivers must meet.

## Training drivers to transport dangerous substances

An employer must make sure that all persons who transport dangerous substances have training directly related to their duties and the tasks they will have to perform. Training must also be appropriate to the type of dangerous substances to be transported.



The employer is also responsible for issuing a training certificate to all employees who handle or transport dangerous substances. This certificate confirms that you have received training concerning dangerous substances. It specifies the areas in which you have been trained, the subjects covered by the training and the certificate's expiry date.

The certificate is valid for 36 months. Drivers must carry the certificate with them at all times when transporting dangerous substances. As a driver, you must carry with you the original or a copy of your training certificate, or else you must be with and under the direct supervision of a person carrying the original or a copy of his or her training certificate, every time you carry dangerous substance in your vehicle.

## Shipping document

Any person taking charge of a shipment of dangerous substances must make sure to obtain a copy of the shipping document, which contains the information required by the *Transportation of Dangerous Substances Regulation*. This copy must remain with the dangerous substances up to the point of delivery.

- ▶ If you are on board the vehicle, the shipping document must be stored in a protective jacket affixed to the driver's side door or must be within easy reach.
  - ▶ If you are not in the vehicle, the document can be placed in either one of the following locations:
    - ▷ in a protective jacket affixed to the driver's side door;
- OR
- ▷ on the driver's seat or in a location where it will be visible to anyone who climbs into the vehicle from the driver's side.

## Labelling dangerous substances

In general, dangerous substances must be labelled using the safety marks prescribed by the *Transportation of Dangerous Substances Regulation*.



Before taking possession of dangerous substances, you must make sure that:

- ▶ the dangerous substances have been classified;
- ▶ the shipper has affixed the appropriate safety marks on the containers (label, placard or sign);
- ▶ the shipper has provided placards to be displayed on the vehicle. These placards must be placed on each end and on each side of the vehicle.

## Class 1 – Explosives

### 1.1

Explosives with a mass explosion hazard (e.g. T.N.T.).



### 1.2

Explosives with a projection hazard, but without a mass explosion hazard (e.g. military shells).



### 1.3

Explosives with a fire hazard and either a minor blast hazard or projection hazard, or both, but not a mass explosion hazard (e.g. fireworks).



### 1.4

Explosives with no significant blast hazard outside their packing in the case of ignition or initiation during transport (e.g. safety fuses and firearm bullets).



Placards are not required for Class 1.4:

- ▶ if the quantity of Class 1.4 explosives is equal to or less than 1,000 kg;
- ▶ if the explosives are of Class 1.4S, regardless of quantity.

### 1.5

Very insensitive explosives with a mass explosion hazard (e.g. blasting agents).



### 1.6

Extremely insensitive detonating articles with no mass explosion hazard (e.g. articles containing very insensitive explosive material).



In Québec, any driver of a vehicle that is transporting explosives listed in the Regulation under the *Act respecting explosives* must obtain an authorization from the Sûreté du Québec.

## Class 2 – Gases

### 2.1

Flammable gases (e.g. propane).



### 2.2

Non-flammable non-toxic gases (e.g. nitrogen).



Placard or label for the following four oxidizing gases:

- ▶ compressed oxygen;
- ▶ liquid refrigerated oxygen;
- ▶ compressed oxidizing gas;
- ▶ liquefied oxidizing gas.



### 2.3

Toxic gases (e.g. carbon monoxide).



## Class 3 – Flammable liquids

Liquids with a flash point equal to or lower than 60.5°C (e.g. gasoline, ethanol, kerosene and diesel fuel).



## Class 4 – Flammable solids, self-igniting substances and substances that release flammable gases on contact with water

### 4.1

Flammable solids (e.g. safety matches).



### 4.2

Spontaneously combustible substances, (e.g. activated carbon).



### 4.3

Water-reactive substances (e.g. sodium).



## Class 5 – Oxidizing substances and organic peroxides

### 5.1

Oxidizing substances (e.g. ammonium nitrate).



### 5.2

Organic peroxides (e.g. benzoyl peroxide).



## Class 6 – Toxic substances and infectious substances

### 6.1

Toxic substances (e.g. arsenic and pesticides).



### 6.2

Infectious substances (e.g. Rabies virus).



## Class 7 – Radioactive substances

Radioactive substances identified in the Packaging and Transport of Nuclear Substances Regulations (e.g. uranium hexafluoride, nucleodensimeter).



Category I – white (label or placard)



Category II – yellow (label or placard)



Category III – yellow (label or placard)



Fissile materials category (label or placard)



## Class 8 – Corrosive substances

Corrosive substances (e.g. sulfuric acid).



## Class 9 – Miscellaneous products, substances or organisms

Miscellaneous products, substances or organisms (e.g. polychlorinated biphenyls (PCBs) and asbestos).

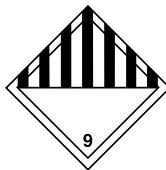

# SPECIAL RULES FOR TRANSPORTING DANGEROUS SUBSTANCES

This section outlines the general points you should be aware of if you drive a heavy vehicle carrying dangerous substances. For more information on each type of cargo, refer to the *Transportation of Dangerous Substances Guide* available from the Ministère des Transports du Québec.



## Cargo securement

All containers used to transport dangerous substances and all other objects must be secured or immobilized by means of structures of adequate strength, blocking systems, bracings, dunnage or dunnage bags, shoring bars, tiedowns or a combination of these.



No container of dangerous substances may be placed on or in front of a motor vehicle's front bumper.

## Cargo inspection by a peace officer

Under the *Highway Safety Code*, if a peace officer asks to inspect your cargo, you must obey the officer's instructions and, if so directed, pull over and stop your vehicle. You must also show the officer all the documents concerning the cargo.

If so requested by a peace officer, you must present the certificate showing that you have received the necessary training to transport dangerous substances.

## Dangerous substances prohibited on road trains

Under the *Transportation of Dangerous Substances Regulation*, the transportation of dangerous substances is prohibited in the following vehicles:

- ▶ a road train more than 25 m in length (a long combination vehicle or “LCV”) if the quantity of dangerous substances requires the display of safety mark placards (pursuant to Part 4 of the *Transportation of Dangerous Goods Regulations*);
- ▶ a double train tank truck, unless it is a type B double train 25-m long or shorter.

## Transportation of dangerous substances prohibited in certain tunnels

Under the *Transportation of Dangerous Substances Regulation*, in certain situations drivers are strictly prohibited from transporting dangerous substances in the signal-light-controlled approaches to the Melocheville tunnel and in the following tunnels:

- ▶ Louis-Hippolyte-La Fontaine (Montréal);
- ▶ Ville-Marie (Montréal);
- ▶ Viger (Montréal);
- ▶ Joseph-Samson (Québec).

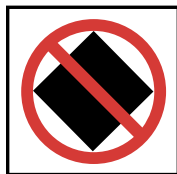

This prohibition applies in the following situations:

- ▶ The quantity of dangerous substances you are carrying requires that placards be displayed on the vehicle, unless the vehicle is carrying only Class 9 dangerous substances.
- ▶ You are carrying a Class 3 flammable liquid and the total capacity of all the containers exceeds 30 L.
- ▶ You are carrying Class 2.1, 2.3 (2.1), 2.2 (5.1) and 2.3 (5.1) gases in more than two cylinders or in a cylinder with a water capacity exceeding 46 L.
- ▶ You are carrying equipment that generates a naked flame or contains incandescent solid fuel.



Given that certain exemptions apply, we recommend you refer to the Transportation of Dangerous Substances Regulation to determine if one of these exemptions applies to your situation.

## Mandatory stopping at level crossings

If the quantity of dangerous substances transported requires that placards be displayed on your vehicle, you must stop at a level crossing. You can proceed through the level crossing once you have made sure that it is safe to cross.

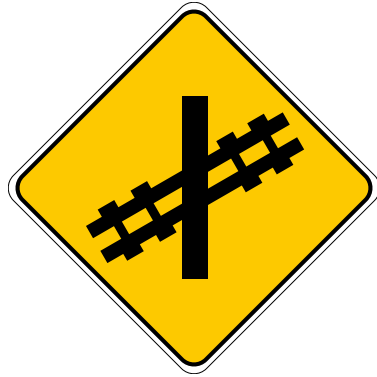

To warn other road users, you should display a sign at the rear of the vehicle such as:

CE VEHICULE S'ARRÊTE AUX PASSAGES À NIVEAU (this vehicle stops at level crossings)

or

ARRÊT AUX PASSAGES À NIVEAU (stops at level crossings)



You can drive through a level crossing without stopping only where road signs or traffic signals indicate that it is permitted to do so.

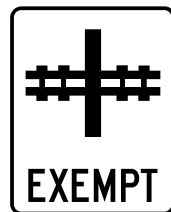

## Accidental spill of dangerous substances

8

If there is a loss, release or leak of dangerous substances, or if an accidental spill of dangerous substances occurs and the quantity discharged exceeds the limits specified in the Regulation, the individual in possession of those substances must immediately notify:

- ▶ the local police;
- ▶ his or her employer;
- ▶ the shipper of dangerous substances;
- ▶ the owner or lessee of the vehicle;
- ▶ CANUTEC, in the case of infectious substances or if the substances were discharged from a damaged gas cylinder (1-888-CAN-UTEC or \*666 on a cell phone).

To find out what quantities of discharged substances require you to immediately notify these authorities, refer to the *Transportation of Dangerous Substances Regulation*.

## Transporting liquefied petroleum gas cylinders

Anyone who transports cylinders of liquefied petroleum gas must comply with the following rules:

- ▶ Do not transport gas cylinders in a vehicle, unless the gas cylinder containment area has outside ventilation.
- ▶ Any gas cylinder placed on the outer rear section of the vehicle must be protected by extending the bumper beyond the cylinder using materials at least as strong as those of the bumper.
- ▶ Never transport a cylinder:
  - ▷ mounted on the vehicle's roof or on one of its doors;
  - ▷ mounted in front of a motor vehicle's front axle;
  - ▷ that extends beyond either side of the vehicle.

For more information about transporting dangerous substances, refer to the *Transportation of Dangerous Substances Guide*, available from the Ministère des Transports du Québec. The guide can be consulted online at [www.transports.gouv.qc.ca](http://www.transports.gouv.qc.ca), where you can find the most up-to-date information about transporting dangerous substances.

## Transportation to the United States

Carriers that transport dangerous substances to the United States must register each year with the U.S. Department of Transportation (USDOT) if the substances so transported meet any of the following criteria:

- ▶ They belong to Class 7 (regardless of their quantity).



- ▶ They consist of over 25 kg of Class 1.1, 1.2 or 1.3 explosives.



- ▶ They consist of over 1 L of products that are toxic when inhaled.



Drivers who transport these dangerous substances to the United States must carry with them a certificate from their employer showing that they have received appropriate training.

# SAFETY TIPS FOR TRANSPORTING CERTAIN CATEGORIES OF GOODS

## 8

### Livestock

Livestock transported by truck must be restrained or in cages to avoid any risk of the vehicle overturning.

### Dry bulk in tank trucks

Because tank trucks have a high centre of gravity, you should avoid sudden steering or braking movements when negotiating a curve or turning at an intersection.

## Liquids in tank trucks

Since transporting liquids or liquefied gases by tank truck requires special skills, here are a few explanations to acquaint you with how liquids move around inside a tank, as well as tips for safe driving.

### Different types of tanks



### Drive carefully

The movement of a liquid in a tank and the vehicle's high centre of gravity create special driving conditions. If a tank is only partly filled, you should avoid sudden steering or braking movements, since the liquid's movement can directly affect your control of the vehicle.



## How changes in temperature affect liquids

To comply with the maximum load restriction specified by the manufacturer on the certification plate, you must take into account the liquid's density and temperature when filling the tank. Some liquids expand when exposed to heat or cold and must be maintained at a controlled temperature.

Liquids such as sulfuric acid are denser than water and might cause your vehicle to exceed authorized weight limits. You must be aware of the properties of your cargo so that you can take the proper precautions. You should know how these liquids react to changes in temperature and be careful not to fill your tank completely. Never fill a tank to more than 70% of its capacity.

## Distribution of liquids in a tank

If a tank has several compartments, take special care to make sure the liquid is distributed evenly in each compartment. To load and unload your vehicle safely, you must make sure the weight is distributed evenly in the tank and avoid placing too much weight at the front or the rear.

## Displacement of liquids in a tank

Controlling a tank truck requires you to drive smoothly, especially when braking or negotiating a curve. When you brake, the liquid forms a wave that travels forward until it strikes the front of the tank, then rebounds toward the rear. When the wave strikes the front or rear end of the tank, it exerts thrust in that direction.

You should also be especially careful in a sharp curve, when exiting a highway and when turning at an intersection, especially if the tank is only part full.

To minimize displacement of liquids, some tank compartments have walls with holes in them, referred to as “baffles,” which stabilize the liquid, yet allow it to move throughout the tank. Side-to-side liquid displacement still occurs, however, and can be powerful enough to overturn the vehicle, especially in a curve or turn.

You must therefore reduce your speed well below the maximum speed limit, especially in slippery road conditions.

# REFLECTIVE STRIPS

Under the *Motor Vehicle Safety Act*, all trailers and semi-trailers 2.05 m wide or wider with a gross vehicle weight rating of 4,500 kg or more must have reflective strips. Only trailers designed exclusively for use as a dwelling or an office are exempt.

In some cases, a series of reflectors may be used instead of reflective strips. The centre of each reflector must be spaced no more than 100 mm from the centre of the adjacent reflectors.

School buses are not required to have reflective strips; however, if they do, the strips must be yellow.

Heavy vehicle owners and operators must comply with the following standards:

	Location of reflective strips	Height	Colour
1	Upper corners, facing the rear	At the top	White
2	Horizontal surface of rear bumper bar, over its entire width, facing the rear	No requirement	Red and white
3	At the rear across the trailer's entire width, facing the rear	As horizontal as possible and as near as possible between 375 mm and 1,525 mm from the ground	Red and white or, on the lower rear and the side of the trailer body, solid white, solid yellow, or yellow and white
4	On each side, facing outward, continuous or equally spaced over at least 50% of the vehicle length, beginning and ending at the far ends	As horizontal as possible and as near as possible between 375 mm and 1,525 mm from the ground	Red and white Yellow and white Solid white Solid yellow

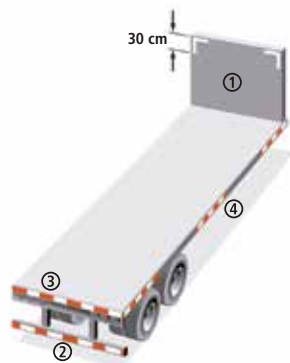
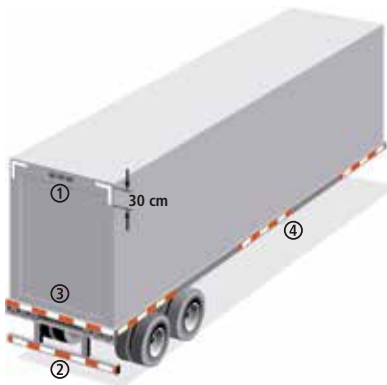

# REGULATION RESPECTING ENVIRONMENTAL STANDARDS FOR HEAVY VEHICLES

## 8

Since June 1, 2006, all heavy vehicle owners are required to take the necessary steps to ensure that their vehicles meet the environmental standards respecting control of heavy vehicle emissions and characteristics of pollution control devices and systems prescribed by the *Regulation respecting environmental standards for heavy vehicles*.

These standards are designed to:

- ▶ reduce the harmful emissions produced by this mode of transportation and, as a result, improve air quality and generate a positive effect on health;
- ▶ ensure that heavy vehicles are better maintained;
- ▶ enable owners to save on fuel.

These standards apply to the following types of vehicles travelling on public roads, regardless of the type of fuel used:

- ▶ road vehicles and combinations of road vehicles, within the meaning of the *Highway Safety Code*, with a gross vehicle weight rating (GVWR) of 4,500 kg or more, except for farm tractors within the meaning of section 2 of the *Regulation respecting the registration of road vehicles* and tool vehicles within the meaning of the *Highway Safety Code*;
- ▶ buses, minibuses and tow trucks within the meaning of the *Highway Safety Code*.

Heavy vehicles that are used in a competition, show or race on a track or field that is closed to all other automobile traffic **are exempt** from these standards.

## Emission control devices and systems

All heavy vehicles subject to the Regulation must be equipped with a properly functioning pollution control device or system that reduces the emission of hydrocarbons, carbon monoxide, nitrogen oxide or particles into the atmosphere.

These standards apply to all heavy vehicles that are operated, sold, leased or placed at the disposal of an individual for valuable consideration in the part of Québec covered by the Regulation, that is, all of Québec except for regions located north of the 55th parallel. These standards therefore apply to the majority of roads in the province's road network.

Heavy vehicle owners may not allow a pollution control device or system installed on any of their vehicles be removed or modified, except to replace it if it is defective.

A replacement pollution control device or system must be equivalent to the device or system used as a replacement unit by the vehicle manufacturer. The manufacturer's code must be indicated on the replacement device or system.

## Roadside emissions testing

# 8

The heavy vehicle environmental standards prescribed by the Regulation may be enforced by means of roadside emissions controlling. These controls are done by carrier enforcement officers on public roads.

Carrier enforcement officers are thus authorized to measure emissions generated by a heavy vehicle if visible exhaust fumes or the odour of the exhaust fumes gives reasonable cause to believe that the vehicle does not meet the requirements of the *Regulation respecting environmental standards for heavy vehicles*.

If the emission levels measured exceed authorized standards, the carrier enforcement officer issues an offence report.

The owner of a vehicle that does not comply with environmental standards will be served a statement of offence by the Ministère de la Justice and a notice by the Ministère du Développement durable, de l'Environnement et de la Lutte contre les changements climatiques requiring the owner to repair the vehicle or have it repaired. The owner must also obtain an attestation of compliance from an accredited repair establishment within 30 days of receiving a repair notice. If the vehicle is used after the 30-day period without the owner having obtained such an attestation, the owner is liable to a fine double the amount of the initial fine. The owner is prohibited from selling a non-compliant vehicle from the time the vehicle is intercepted by carrier enforcement officers until the time the attestation of compliance is issued.



For more information on the Programme d'inspection et d'entretien des véhicules automobiles lourds (PIEVAL or heavy vehicle inspection and maintenance program), visit [www.pieval.gouv.qc.ca](http://www.pieval.gouv.qc.ca).

# SELF-EVALUATION EXERCISES



## Theoretical Exercises

### True or false

---

1. Indicate whether the following statements are true or false.

	True	False
1. The same cargo securement methods can be used for any type of load.	<input type="checkbox"/>	<input type="checkbox"/>
2. If cargo has been properly secured, there is no need to check it during your trip.	<input type="checkbox"/>	<input type="checkbox"/>
3. When transporting dangerous substances, you or a person accompanying you are required to carry the original or a copy of the certificate attesting that one of you has received the necessary training.	<input type="checkbox"/>	<input type="checkbox"/>
4. If a tank truck carrying liquids is equipped with baffles, the movement of the liquid inside the tank cannot cause the vehicle to overturn.	<input type="checkbox"/>	<input type="checkbox"/>
5. A carrier enforcement officer can inspect a heavy vehicle that shows signs of excessive emissions and can issue an offence report.	<input type="checkbox"/>	<input type="checkbox"/>

Answers at the end of the guide.



# HITCHING, UNHITCHING AND DRIVING A DOUBLE ROAD TRAIN

9

---

This chapter presents the information you need to operate a double road train, which is a combination of vehicles consisting of two semi-trailers hitched to a fifth-wheel tractor. The matters discussed include:

- ▶ hitching and unhitching techniques;
- ▶ factors that affect how these types of vehicles should be driven;
- ▶ techniques for driving a double road train.

To drive these types of heavy vehicles, you must hold a Class 1 driver's licence with the appropriate endorsements (M, F, T) depending on the vehicle's characteristics.

Some double road trains exceed the maximum length of 25 m prescribed for such vehicles in the *Vehicle Load and Size Limits Regulation*. They are called longer combination vehicles (LCVs). To be authorized to operate on the road, LCVs must have certain characteristics and comply with specific conditions, which are explained in Chapter 10.

# HITCHING AND UNHITCHING A TRACTOR AND A SEMI-TRAILER

## Hitching a tractor and a semi-trailer both equipped with air suspension

It is very important for a heavy vehicle driver to master the correct technique for hitching a semi-trailer. Any error during the hitching process or using the wrong method can cause an accident or equipment failure.

You must be sure to follow the same steps and proceed in the same manner each time you hitch a semi-trailer. This saves time and ensures that you will be able to drive safely.

The following method explains how to correctly hitch a semi-trailer equipped with air suspension (i.e. one not equipped with a manual air release valve) to a fifth-wheel tractor equipped with the same type of suspension.

Pay close attention so that you perform the manoeuvres safely.

Steps to follow

## 1. Check the tractor's fifth wheel.

- ▶ Make sure the fifth wheel is well lubricated and that its mechanisms show no sign of damage.
- ▶ Make sure the fifth wheel is firmly anchored to the tractor chassis frame.
- ▶ Make sure the fifth wheel is in the correct position to be hitched:
  - ▷ fifth wheel tilted down towards the rear;
  - ▷ fifth wheel jaws completely open.
- ▶ In winter, remove any snow that has accumulated to make sure the fifth wheel locks correctly.



## 2. Position the tractor in front of the semi-trailer.

- ▶ Check the surroundings to make sure you are in a good location for hitching the semi-trailer safely.



- ▶ Line the tractor up in a straight line with the semi-trailer. Roll down the window to hear what is going on and look in the outside rearview mirrors to check both sides of the semi-trailer. Do not hitch the semi-trailer until the tractor is lined up with the semi-trailer.
- ▶ Back up slowly and make sure the axle fits under the semi-trailer.
- ▶ Put on the tractor's parking brake, shift into neutral, switch on the hazard lights and parking lights, and climb down from the tractor cab using three support points.
- ▶ Adjust the height of the semi-trailer:
  - ▷ if it is too high, lower the semi-trailer using the landing gear;
  - ▷ if it is too low, lower the tractor's suspension or raise the semi-trailer using the landing gear.
- ▶ The upper coupler plate of the semi-trailer should be slightly lower than the fifth wheel plate when it is at its pivot point. If the upper coupler plate is lower, the semi-trailer will be slightly raised when it is hitched, making it easier for the locking mechanism to engage.
- ▶ Check the condition of the kingpin and the upper coupler plate on the semi-trailer. If necessary, remove the latch on the kingpin.



### 3. Hitch the semi-trailer.

- ▶ Climb into the tractor and release the parking brake.
- ▶ Back the tractor up slowly under the semi-trailer, as you check the outside rearview mirrors, until the upper coupler kingpin is positioned inside the fifth wheel. This manoeuvre must be performed correctly to make sure that the locking mechanism is engaged and to prevent the kingpin from striking hard against the inside of the fifth wheel.
- ▶ Check that the fifth wheel is locked securely by trying to move the tractor forward. Stop as soon as you feel resistance.
- ▶ Put on the tractor's parking brake and shift into neutral.
- ▶ Before climbing down from the tractor, switch on the semi-trailer's hazard lights, parking lights and clearance lights.
- ▶ Climb down from the tractor using three support points.

## 4. Inspect coupling, and complete the procedure.

- ▶ Look under the semi-trailer at the rear of the tractor to:
  - ▷ check that the kingpin is fully inserted into the jaws, using a flashlight if necessary;
  - ▷ check that the fifth wheel locking mechanism is in the lock position. If it does not lock, ask a mechanic for help.
- ▶ Connect the indicator lights and brake hoses and make sure that they cannot be damaged by the vehicle's movements.
- ▶ Raise the landing gear and place the crank in the bracket.
- ▶ Turn on the semi-trailer's air suspension by hand if necessary.



## Unhitching a semi-trailer with air suspension

First make sure that you are in a good spot for unhitching the semi-trailer. Choose an area where the ground is firm enough and flat enough to support the weight of the semi-trailer.



Steps to follow

### 1. Park the tractor and semi-trailer in the correct position for unhitching

- ▶ Line the tractor up straight with the semi-trailer.
- ▶ Put on the tractor and semi-trailer parking brakes, shift into neutral and climb down from the tractor using three support points.
- ▶ Check the condition of the semi-trailer (lights, tires, etc.).
- ▶ Lower the landing gear until it is braced firmly against the ground.
- ▶ Unhook the brake hoses and indicator lights. Connect them to the dummy couplers behind the tractor cab.
- ▶ Pull the fifth wheel release lever or levers until they are in the “open” position.





## 2. Unhitch the tractor from the semi-trailer

- ▶ Climb back into the tractor, press down on the tractor's parking brake knob and select the right gear.
- ▶ Move the tractor forward approximately 15 cm to release the kingpin from the fifth wheel and bring the vehicle to a stop.
- ▶ Lower the tractor's air suspension and move forward slowly.
- ▶ Bring the tractor to a stop while the last axle is still under the semi-trailer. This precaution ensures that the semi-trailer will be supported if the landing gear fails or sinks into the ground.
- ▶ While still in the cab, check that the semi-trailer is immobilized before driving forward, or before climbing down from the tractor to check the landing gear if you are in doubt about its stability. If you climb down from the tractor, always use the proper safety procedure:
  - ▷ put on the tractor's parking brake, shift into neutral;
  - ▷ before climbing down from the tractor, switch on the semi-trailer's hazard lights, parking lights and clearance lights;
  - ▷ climb down from the tractor using three support points.
- ▶ Slowly move the tractor away from the semi-trailer and turn the tractor's suspension back on.



# HITCHING AND UNHITCHING A DOUBLE ROAD TRAIN

A second semi-trailer can be hitched to the first semi-trailer using the following equipment:

- ▶ an A converter dolly with one pintle eye, in the case of an A train;
- ▶ a sliding fifth wheel below the first semi-trailer or a stationary fifth wheel secured to the back of the semi-trailer, in the case of a B train;
- ▶ a tandem-axle B converter dolly with 2 pintle eyes, in the case of a C train.

This equipment can be used for hitching all double road trains.

## Hitching a B train

Steps to follow

- 1. Hitch the first semi-trailer to the tractor following the method described previously**
- 2. Position the tractor and the first semi-trailer already hitched together in front of the second semi-trailer**

- ▶ Line up the tractor and the first semi-trailer combination in a straight line with the second semi-trailer. Roll down the window to hear what is going on and look in the outside rearview mirrors to check both sides of the semi-trailer. Do not hitch the second semi-trailer until the tractor and the first semi-trailer combination is lined up with it.
- ▶ Back up slowly and make sure the axle fits under the second semi-trailer.
- ▶ Put on the tractor and the first semi-trailer parking brakes, shift into neutral and climb down from the tractor using three support points.



### 3. Inspect the second semi-trailer

- ▶ Check the condition of the kingpin and the upper coupler plate. If necessary, remove the latch on the kingpin.
- ▶ Adjust the height of the second semi-trailer:
  - ▷ if it is too high, lower it using the landing gear;
  - ▷ if it is too low, raise it using the landing gear.

### 4. Hitch the second semi-trailer

- ▶ Climb into the tractor and release the parking brake.
- ▶ Slowly back up the tractor and the first semi-trailer hitched together under the second semi-trailer, as you check the alignment in the rearview mirrors.



Continue backing up until the upper coupler kingpin is positioned inside the fifth wheel. This manoeuvre must be performed correctly to make sure that the locking mechanism is engaged and to prevent the kingpin from striking hard against the inside of the fifth wheel.

- ▶ Check that the fifth wheel is locked securely by trying to gently move the tractor and the first semi-trailer forward.
- ▶ Stop as soon as you feel resistance.
- ▶ Put on the tractor and the first semi-trailer parking brakes, shift into neutral and switch on the semi-trailer's hazard lights, parking lights and clearance lights.
- ▶ Climb down from the tractor using three support points.
- ▶ Look under the second semi-trailer at the rear of the trailer hitch to:
  - ▷ check that the kingpin is fully inserted into the jaws, using a flashlight if necessary;
  - ▷ check that the fifth wheel locking mechanism is in the lock position.

## 5. Inspect coupling, and complete the procedure

- ▶ Connect the indicator lights and brake hoses. Make sure that they cannot be damaged by the vehicle's movements.
- ▶ Open the brake line shut-off valves of the first semi-trailer.
- ▶ Raise the landing gear, place the crank in the bracket and, if necessary, arrange any additional brackets.
- ▶ Turn on the second semi-trailer's air suspension, if necessary.



## Hitching an A or C train

Steps to follow

- 1. Hitch the first semi-trailer to the tractor using the method described above.**
- 2. Position the tractor and the first semi-trailer combination to attach the dolly**

- ▶ Back up the tractor and the first semi-trailer combination in front of the dolly, so that the dolly's pintle eye is lined up straight with the first semi-trailer's pintle hook.
- ▶ Put on the tractor and first semi-trailer parking brakes, shift into neutral and switch on the appropriate hazard lights and parking lights.
- ▶ Climb down from the tractor using three support points.
- ▶ Check that the dolly's pintle eye and the first semi-trailer's pintle hook are lined up correctly.
- ▶ Climb back into the cab to back up the tractor and the first semi-trailer combination until the dolly's pintle eye is centred in the first semi-trailer's hook so that the dolly can be hitched.
- ▶ Climb back down from the tractor using three support points after completing standard procedures.
- ▶ Lower the dolly's drawbar and put the safety catch in place.



- ▶ Connect the dolly's brake hoses and indicator lights to the first semi-trailer and install the safety chains.
- ▶ Open the brake line shut-off valves from the first semi-trailer to the dolly.
- ▶ Check the general condition of the dolly.
- ▶ Climb into the tractor and release the parking brakes.
- ▶ Back up the tractor, first semi-trailer and dolly combination until approximately 30 cm in front of the second semi-trailer.
- ▶ Put on the tractor and semi-trailer parking brakes, shift into neutral, switch on the hazard lights and parking lights, and climb down from the tractor using three support points.



### 3. Inspect the second semi-trailer

- ▶ Look under the second semi-trailer and check that the dolly's fifth wheel and the kingpin are lined up.
- ▶ Check the condition of the kingpin and the upper coupler plate. If necessary, remove the latch on the kingpin.
- ▶ Adjust the height of the second semi-trailer:
  - ▷ if it is too high, lower it using the landing gear;
  - ▷ if it is too low, raise it using the landing gear.

## 4. Hitch the dolly to the second semi-trailer

- ▶ Make sure that the second semi-trailer's upper coupler is slightly lower than the dolly's fifth wheel plate when it is at its pivot point. If the second semi-trailer's upper coupler is lower, it will be slightly raised when it is hitched, making it easier for the locking mechanism to engage.
- ▶ Climb into the tractor and release the parking brake.
- ▶ Slowly back up the tractor, first semi-trailer and dolly combination under the second semi-trailer, as you check the outside rearview mirrors, until the upper coupler kingpin is positioned inside the fifth wheel. This manoeuvre must be performed correctly to make sure that the locking mechanism is engaged and to prevent the kingpin from striking hard against the inside of the fifth wheel.
- ▶ Test the locking mechanism by moving the vehicle combination forward until you feel resistance.





## 5. Inspect coupling, and complete the procedure

- ▶ Put on the tractor and the first semi-trailer parking brakes, shift into neutral, switch on the hazard lights and parking lights, and climb down from the tractor using three support points.
- ▶ Visually inspect the locking mechanism, using a flashlight, if necessary.
- ▶ Connect the brake hoses and indicator lights to the second semi-trailer.
- ▶ Open the dolly's brake line shut-off valves.

For double road trains that are 25 m long or shorter, some drivers prefer to hitch the dolly to the tractor first in order to position the dolly in front of the second semi-trailer. This procedure is described briefly below:

1. Hook the dolly to the tractor using the drawbar.
2. Line up, unhook and position the dolly approximately 30 cm in front of the second semi-trailer, making sure the axle fits under the second semi-trailer (do not hitch the dolly to the second semi-trailer at this point).
3. Hitch the first semi-trailer following the usual procedure.
4. Position the tractor and the first semi-trailer in front of the dolly.
5. Hook the dolly to the first semi-trailer already hitched to the tractor.
6. Back up the vehicle combination and hitch the dolly to the second semi-trailer, then check all the usual items. Do not forget to check the dolly, brake hoses, indicator lights and safety chains.

## Unhitching a double road train

To unhitch an A, B or C train, follow the procedure used for unhitching a single semi-trailer from a tractor.

When unhitching a B train, however, additional landing gear, if the vehicle is so equipped, must be placed under the second semi-trailer to prevent it from falling over.

Follow the steps explained below to unhitch an A or C train:

1. Park the double road train in a straight line in a location where there is enough space and on a firm level surface.
2. Close the air shut-offs from the dolly to the first semi-trailer.
3. Unhitch the second semi-trailer using the same method as for unhitching the first semi-trailer.
4. Unhook the dolly in a safe location for an A or C train. The dolly can be positioned a short way in front of the second semi-trailer or in any other suitable location.

**Caution:** Never unlock the heel of the tow hook when the dolly is still under the second semi-trailer, because the dolly's drawbar could fly up without warning. Since it is almost impossible to straighten out a drawbar, a dolly with a damaged drawbar will likely never be used for service again.

5. Unhitch the first semi-trailer from the tractor following the usual procedure.

Even though you do numerous checks all throughout the hitching process, you have to perform a circle check on the entire vehicle combination when everything is hitched up and ready to go. This is your opportunity to do a final check on the hitching system before heading out on the road.

# PHYSICAL FACTORS THAT AFFECT DRIVING

## 9

### Load distribution in the vehicle

In situations where you have to react quickly, you run the risk of losing control of the double road train you are driving if the load is not evenly distributed in the semi-trailers. You therefore need to pay special attention to how the cargo is distributed, even if you have no control over this.

To improve the stability of a double road train and to avoid overturning, the centre of gravity must be as low as possible.

In short, to avoid braking, traction and steering problems, the load in each semi-trailer must be distributed properly over the axle groups in compliance with the *Vehicle Load and Size Limits Regulation*.

It is also very important to position the semi-trailers in a double road train based on their weight. The longest and heaviest semi-trailer must be hitched to the tractor. If the semi-trailers are not positioned in this order, you could lose control of the second semi-trailer when you brake.

Bear in mind that increasing a vehicle's load tends to reduce its acceleration force. This means that a double road train will require more time to enter the stream of traffic or to resume speed after stopping. The extra load also forces you to reduce your speed even more in curves.

## Length of a double road train

Because of its length, a double road train does not perform as well as shorter vehicles when the driver is passing or is forced to make evasive manoeuvres to avoid colliding with other vehicles. Also, crosswinds tend to aggravate this problem, especially when you are negotiating a curve. You have to pay careful attention to these phenomena so that you can anticipate how your vehicle will react. This will enable you react in time and maintain control of your vehicle.

## Number of articulations

When driving a double road train, there are numerous factors that determine how much space you will need in order to safely execute various manoeuvres, particularly when turning. Among other things, you must consider:

- ▶ the number and position of axles;
- ▶ the length of the tractor and of each semi-trailer;
- ▶ the number of articulations.

The more articulations a vehicle combination has, the greater the risk of the second semi-trailer weaving back and forth. When this occurs, the second semi-trailer may deviate from the tractor's trajectory and cross over into the next lane. This can lead to accidents with other vehicles and even cause the double road train to overturn.

Since double road trains take up a lot of space on roads, the risks of colliding with roadside installations, parked vehicles or pedestrians are greater.

# DRIVING A DOUBLE ROAD TRAIN

Generally speaking, if you have mastered the driving techniques for tractor semi-trailers, you already have the skills you need to drive a double road train. When driving one of these vehicle combinations, however, you have to pay attention to the following:



- ▶ Each vehicle combination has its own special characteristics and its own way of reacting in different weather conditions. Getting a double road train to begin moving forward on slippery pavement may be difficult because with this type of vehicle combination, the wheels are more likely to begin spinning in place. A double road train is also more likely to go into a skid when travelling on a level road or up a grade, when the road is covered with snow, or even when the pavement is just wet.
- ▶ You must therefore be aware of how handling a double road train differs from handling other types of heavy vehicles.
- ▶ You need to be familiar with how a double road train handles because, sooner or later, you will find yourself facing an unexpected hazard. You will have to be able to react immediately and know what to do.
- ▶ The first rule to follow at all times is to drive safely and defensively. This will enable you to anticipate and avoid hazardous situations before they arise. Any delay in correcting a situation that threatens your safety can result in an accident.

### HOW TO DRIVE DEFENSIVELY

- ▶ Obey the speed limits, road signs and traffic signals.
- ▶ Pay constant attention to how your vehicle is reacting and to how your driving environment is changing.
- ▶ Perform your driving manoeuvres smoothly.
- ▶ Look far ahead so that you can anticipate any problems that might arise. This will help you to avoid having to brake frequently or change gears or directions abruptly to avoid a collision.
- ▶ Apply the brakes gradually to prevent your wheels from locking up and to minimize the risk of jackknifing. This type of accident occurs when the angle of lateral rotation between a fifth-wheel tractor and a semi-trailer exceeds 90°.
- ▶ Be courteous to other road users: this makes the road a safer place for you and for others.
- ▶ Plan your route so as to minimize the distance you will have to travel.
- ▶ Watch out for the warning signs of fatigue.
- ▶ Check your rearview mirrors regularly to make sure the second semi-trailer is not weaving from side to side. This will help prevent losing control of your vehicle.

## Driving in a straight line and risk of fishtailing

Various factors, such as bumpy roads, high winds or abrupt turns of the steering wheel, can cause a second semi-trailer to weave back and forth. This type of motion, referred to as “fishtailing,” is a typical problem for drivers of double road trains. When you change lanes, for example, the second semi-trailer may begin to swing widely from side to side. The fishtailing can gradually increase to the point where the second semi-trailer overturns.

It may be difficult for you to immediately detect when your semi-trailer is fishtailing, and this delay can reduce your available reaction time.

You can maintain control of your vehicle, however, by staying focused on what is happening on the road and by checking your rearview mirrors regularly.

## Braking

In theory, the braking capacity of a double road train is greater than that of a tractor semi-trailer. This increased braking capacity is due primarily to the greater number of wheels, which thereby enhances the effect of the brake system. In practice, however, the more axles and articulations a combination vehicle has, the harder it is to brake evenly, i.e. to stop the tractor and the semi-trailers at the same time and with the same braking power.



Since maximum braking efficiency is important throughout a trip, good drivers avoid braking abruptly or applying the brakes over an extended length of time. To do this, you must drive safely and defensively.

To avoid having to brake frequently, you should be constantly monitoring the movement of traffic and adjust your speed accordingly. You should also leave enough space between you and the vehicle in front of you.

By using the method explained below, you can determine the ideal interval in seconds between you and the vehicle ahead of you, no matter how light or heavy the traffic or what kind of road you are travelling on: city, country, etc. To do this, professional drivers usually divide the length (in metres) of their vehicle by three and count one second for every three metres. For example, if you are driving a 24 m double road train, you should maintain a space corresponding to an interval of 8 seconds between your vehicle and the one in front of you ( $24 / 3 = 8$ ).

#### HOW TO MAINTAIN A SAFE DISTANCE BETWEEN VEHICLES

- ▶ Choose a stationary object by the roadside, such as a road sign, as a point of reference.
- ▶ When the vehicle ahead of you reaches that point, start counting out the seconds like this: "one thousand and one," "one thousand and two" and so on until you reach "one thousand and eight" (assuming your vehicle is a 25-m double road train).
- ▶ If you reach the reference point before you get to "one thousand and eight," this means that you are following the vehicle ahead of you too closely.
- ▶ Start over again and try to maintain the proper distance between your own vehicle and the vehicle ahead of you.

If, despite these precautions, you are forced to brake abruptly, the most important thing is to avoid causing your wheels to lock up. To make sure this does not happen, your brake system must be in good working order and the weight of the load must be properly distributed over the axles.

It is important to remember the following points:

- ▶ If the front wheels of your tractor lock up, you cannot steer properly.
- ▶ If the back wheels of your tractor lock up, your vehicle could jackknife.
- ▶ If the wheels of the second semi-trailer lock up, it may begin fishtailing.



Each time you brake, you should check in your rearview mirrors to see how the semi-trailers react.

Be careful when using your retarders because they act only on your drive wheels. On slippery roads, some types of retarders can cause your drive wheels to lock up and cause your vehicle to jackknife.

Most tractors and semi-trailers are equipped with an anti-lock brake system (ABS), which ensures greater vehicle stability, better steering control and, in general, shorter braking distances. But you must remain alert and be ready to take control if an unexpected hazard arises.

## Negotiating a curve and turning at an intersection

When turning at an intersection or negotiating a curve, you must evaluate how much space your tractor and semi-trailers will need. You must take into account the fact that the rear axles of the second semi-trailer tend to cross over into the other lane as you are turning.

Just how far they cross over into the other lane depends on your vehicle's total length and the adjustment of the fifth wheel and the axle. It is easier to make turns with a B train because this type of vehicle combination usually has a shorter wheelbase. An A train, on the other hand, has three pivot axes, so its wheelbase is longer and it is harder to turn.

Basically, you have to coordinate speed and direction in order to steer your vehicle exactly where you want it to go when making a turn.

## Right turns

For the driver of a heavy vehicle, turning right is the hardest manoeuvre to execute due to the risk of colliding with vehicles travelling in the adjacent lane. Be extra cautious and clearly visualize the turn you are preparing to make. Then:

1. Keep your vehicle in the right lane and be on the lookout to prevent other road users (vehicles, cyclists, motorcyclists, pedestrians, etc.) from venturing into the space between the side of the road and your vehicle.
2. After looking left, right and then left again to make sure that the way is clear, start making your turn holding the front end of your vehicle close to the dividing line on the left side of the lane you want to enter. Even though it is prohibited by law to do so, road configuration and vehicle size sometimes leave you no other choice but to trespass slightly into the next lane. If you do this, make sure the way is clear and remain alert to vehicles that might appear unexpectedly.
3. Continue straight ahead, close to the dividing line, and make sure your rear wheels do not trespass onto the sidewalk or shoulder.
4. Steer your vehicle back to the centre of the lane.
5. Stay in the left lane after completing the turn if you expect to be making a left turn up ahead. If you are not planning to make a left turn, edge your vehicle over into the right lane, as shown in the illustration.

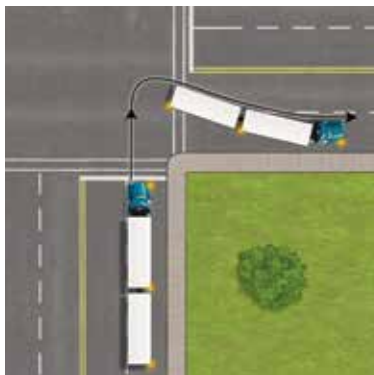

Limit the space between your vehicle and the side of the road as much as possible, and remain alert throughout the manoeuvre to prevent other road users from venturing into this space.

## Left turns

To make a left turn safely, in general you must:

1. Steer your vehicle into the left lane.
2. After looking left and right to make sure that the way is clear, steer your vehicle so that its front end is close to the dividing line of the other road and edge over to the right side of the lane you are entering. If you do not have enough space, it is sometimes necessary to trespass slightly into the other right-hand lane after making sure the way is clear.
3. Continue straight ahead, close to the right-hand dividing line, until you have almost completed your turn, making sure that your rear wheels do not cross over the centre line.
4. Steer your vehicle back to the centre of the lane.

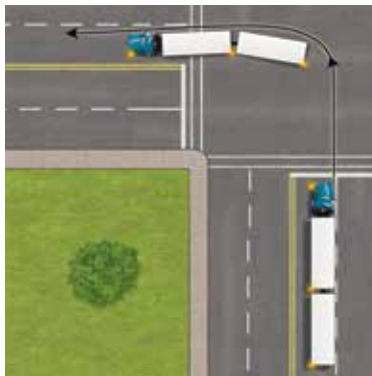

Due to the configuration of your double road train, you may have to trespass into the far right-hand lane to complete your left turn so as to avoid having to make successive lane changes, as explained in Chapter 5. If you do this, however, you must be very careful, because if there is another vehicle in a parallel lane turning left at the same time as you or coming from the opposite direction and turning right, the other vehicle has the right of way.

## Passing and avoiding obstacles

Your pup semi-trailer is at risk of overturning if you steer sharply to one side to avoid an obstacle.

You can take steps to prevent this from occurring if you choose the proper equipment and make certain adjustments. By using hard tires and by properly adjusting the suspension, axle placement and fifth wheel position, you can reduce the risk of overturning.

The way you drive is also important. You can reduce the risk of overturning by:

- ▶ scanning the road up ahead;
- ▶ reducing your speed;
- ▶ changing lanes as soon as you detect any unexpected hazard;
- ▶ avoiding turning the steering wheel any more than necessary: the more you turn the steering wheel, the greater the risk of overturning or jackknifing;
- ▶ avoiding turning the steering wheel sharply when manoeuvring around an obstacle.

## Being passed by another vehicle

The longer a vehicle is, the greater the time and distance required to overtake it. However, other road users preparing to pass a double road train are usually unaware of how long the vehicle is and how its size affects its braking time. As a result, they may misjudge the time needed to pass a double road train. And they may not realize the danger of pulling back over into the right lane too quickly after passing a double road train without allowing enough space between the two vehicles.

To make it easier for another road user to overtake your double road train and pass you, reduce your speed and stay in the right-hand lane, but do not edge over onto the shoulder. If the road is wet, stay out of any ruts in the pavement to avoid splashing water onto the vehicles passing you. Remain vigilant at all times.

## Passing another vehicle

Here are a few tips to make it easier to pass another vehicle safely:

- ▶ Pass another vehicle only where road signs allow it and obey the speed limits.
- ▶ Make sure that you are able to overtake the other vehicle with no danger and check to be sure there are no other vehicles trying to overtake you as you are preparing to pass.
- ▶ Make sure your vehicle has enough accelerating power for you to pass the other vehicle.
- ▶ After overtaking the other vehicle, allow enough space behind you before pulling back over into the right lane.

# SKIDDING, OVERTURNING AND JACKKNIFING

The most common accidents involving a road train or double road train are skidding, overturning and jackknifing.

These kinds of accidents usually occur when the vehicle's centre of gravity is too high or too low, or when the road is wet or covered with snow.

On dry pavement, skidding usually occurs when your vehicle's centre of gravity is very high. The danger of overturning is generally greatest in a curve or during high winds. Jackknifing, in most cases, is the result of braking abruptly on a wet or snow-covered road surface with a vehicle having a fairly low centre of gravity. The best way to prevent these types of accidents is to be alert for situations where they are likely to occur and reduce your speed.

## Potential skidding, overturning and jackknifing situations

- ▶ Skidding, overturning and jackknifing are usually due to driving too fast, momentary distractions, errors in handling the steering wheel, or braking abruptly.
- ▶ For example, if you are driving too fast and you miscalculate the amount of space you need to take a highway exit, you may hit the edge of the exit ramp or the guard rail, go into a skid or even cause your vehicle to overturn.
- ▶ When one wheel of a double road train skids onto the shoulder, this can be enough to send your vehicle into the ditch. To avoid this, stay well within your lane and make sure none of your wheels crosses over onto the shoulder.
- ▶ Too much or too little air in your tires can also cause an accident. An empty double road train with over-inflated tires can jackknife if you brake abruptly. This type of accident can occur during a hot summer day, for example, after you have been driving your vehicle a long time. Tires that are under-inflated (a “slow leak” tires completely deflated, etc.) can cause you to lose control of your vehicle.
- ▶ If your brakes are not properly adjusted, they can cause you to jackknife.

## Tips to prevent jackknifing

Jackknifing usually occurs when you reduce your speed while negotiating a curve or when turning. If you drive a road train or double road train, you have to take into account the numerous points of articulation of your vehicle combination and adjust your speed to road conditions. Wind, visibility and tire traction are factors you must always consider.

For example, when the angle of the jackknife is over 15°, it means you have reached the point of no return. At this point, it is almost impossible to regain control of your vehicle.

The best way to avoid skidding, overturning and jackknifing is simply to practise the basic techniques of defensive driving: **obey the speed limits and treat other road users courteously.**



# SELF-EVALUATION EXERCISES



## Theoretical Exercises

### True or false

1. Indicate whether the following statements are true or false.

	True	False
1. To hitch a semi-trailer, the upper coupler plate on the semi-trailer must be slightly lower than the fifth wheel plate at its pivot point.	<input type="checkbox"/>	<input type="checkbox"/>
2. To unhitch a semi-trailer, you must move the tractor forward slightly to release the upper coupler kingpin, stop the vehicle, lower the tractor's suspension and drive forward slowly.	<input type="checkbox"/>	<input type="checkbox"/>
3. The lightest semi-trailer is the one that should be hitched to the tractor.	<input type="checkbox"/>	<input type="checkbox"/>
4. On slippery roads, braking abruptly can cause jackknifing.	<input type="checkbox"/>	<input type="checkbox"/>
5. A right turn is the easiest manoeuvre to perform when driving a heavy vehicle.	<input type="checkbox"/>	<input type="checkbox"/>

Answers at the end of the guide.



# DRIVING A LONGER COMBINATION VEHICLE (LCV)

10

---

The loads and sizes of some road trains exceed the standards of the Ministère des Transports du Québec. In general, such road vehicle combinations, which may be type A, B or C, are over 25 m in length.

In this chapter, these vehicles are known as “longer combination vehicles” (LCVs). To operate an LCV, you must comply with the conditions of the *Special Road Train Operating Permits Regulation*. You must also hold a Class 1 driver’s licence bearing a T endorsement. To be eligible for the T endorsement, you must have sufficient experience driving a combination of road vehicles. You must have held a Class 1 driver’s licence for at least 5 years and have successfully completed special training.

This chapter details the information that LCV drivers must know, such as:

- ▶ the dimensions and features of LCVs covered by the *Special Road Train Operating Permits Regulation*;
- ▶ the roads on which LCV drivers are authorized to operate;
- ▶ the conditions LCV drivers must meet in order to operate such a vehicle.

LCVs can carry a larger volume of cargo than regular double road trains. Because of their larger capacity, LCVs can transport the same amount of goods at a lower rate of fuel consumption and at lower labour and maintenance costs. These savings are one of the reasons why LCVs are popular with heavy vehicle operators.

However, LCVs are harder to operate due to the length and dynamic behaviour of this type of vehicle combination. To safeguard road users, drivers must comply with the specific requirements of the *Special Road Train Operating Permits Regulation*. LCV drivers must have a thorough understanding of this Regulation, in addition to the rules of the *Highway Safety Code*.

# SPECIAL OPERATING PERMIT

Certain LCVs may exceed the total loaded mass and the length prescribed by the *Vehicle Load and Size Limits Regulation*. In such a case, the operator or owner must obtain a special operating permit. This permit is issued by the Ministère des Transports du Québec and can be obtained on its website ([www.transports.gouv.qc.ca](http://www.transports.gouv.qc.ca)).

When operating an LCV on the road network, you must carry the original permit papers and its appendices with you at all times.

## Special permit validity period

A special road train operating permit is valid for a maximum of twelve consecutive months.

# TYPES OF LCVs COVERED BY THE REGULATION

# 10

A special road train operating permit may be issued to authorize operation of the following types of LCVs:

A or C double road train

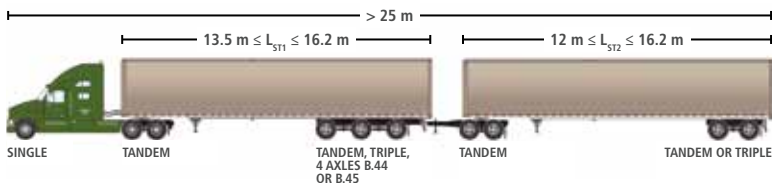

- ▶ an **A double road train** consisting of a tractor, a semi-trailer and a tandem-axle single drawbar dolly that converts the second semi-trailer into a trailer;
- ▶ a **C double road train** consisting of a tractor, a semi-trailer and a tandem-axle double drawbar dolly that converts the second semi-trailer into a trailer;

B double road train

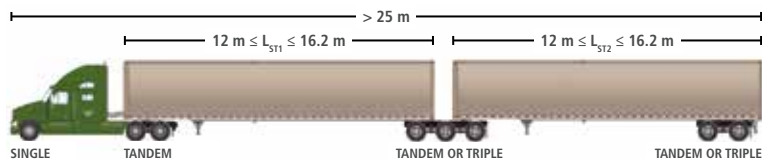

- ▶ a **B double road train** consisting of a tractor, a semi-trailer and a semi-trailer resting on a fifth wheel mounted at the rear of the first semi-trailer;

Other double road train

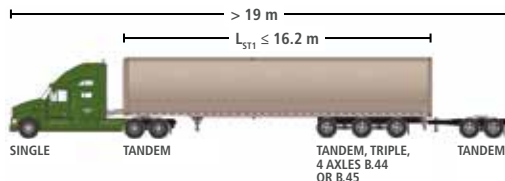

- ▶ a **double road train** consisting of a tractor, a semi-trailer and a tandem-axle dolly.

## Characteristics of LCVs

- ▶ **Total loaded mass:**

The maximum load limit is 67,500 kg.

However, for an LCV consisting of a tractor, semi-trailer and tandem-axle dolly (excluding the second semi-trailer), the total loaded mass must be within regulatory limits prescribed for the tractor and the semi-trailer, plus 2,000 kg.

To find out more, see the *Vehicle Load and Size Limits Regulation*.

- ▶ **Minimum horsepower of the tractor**

The tractor must have at least 1 HP per 180 kg of the LCV's total loaded mass. The tractor must also be equipped with an air compressor with a capacity of at least 425 L per minute to supply the brake system.

- ▶ **Length of first semi-trailer**

The maximum length of the first semi-trailer is 16.2 m, but the minimum length varies depending on the type of train. The minimum lengths is:

- ▷ 12 m for a B train;
- ▷ 13.5 m for an A or C double road train.



► **Length of second semi-trailer**

For all types of double trains, the maximum length of the second semi-trailer is 16.2 m and the minimum length is 12 m.

► **Driver monitoring system**

An LCV must be equipped with a device to track the driver's behaviour. This device must record any wide variations in speed and relevant data concerning date, time and speed

► **Signage**

A warning sign bearing the word "LONG" must be placed on the rear of the second semi-trailer. The sign must be 230 to 245 cm by 30 cm in size and comply with the manufacturing standards set forth in the *Special Road Train Operating Permits Regulation*. The sign must be rigid and must remain free of any object, substance or dirt.

Note that the warning sign is not required for an LCV made up of a tractor, semi-trailer and tandem axle dolly to which no semi-trailer is hitched.



► **Load**

The semi-trailer with the greatest total loaded mass must always be hitched to the tractor, except where the weight difference between the two semi-trailers is less than 10%.

► **Travel in a straight line**

Neither of the semi-trailers may swing more than 80 mm out of line with the tractor to either side when the LCV is travelling in a straight line.

► **Dolly**

If there is a dolly, it must be equipped with a pilot relay valve designed to boost the braking signal of the second semi-trailer. In the case of a C double train, the dolly must meet the requirements of section 903 of the *Motor Vehicle Safety Regulation* under the *Motor Vehicle Safety Act*.

The axles of an LCV must also have the following characteristics:

- The **tractor** must be equipped with a front single axle and a rear tandem axle, have an interaxle spacing of at least 3.5 m (as measured from the axis of rotation of the single axle to the axis of rotation of the first axle of the tandem axle) and a wheelbase of 6.2 m or less (as measured from the axis of rotation of the single axle to the centre of the tandem axle).
- The **first semi-trailer** of a B train must be equipped with a tandem axle or triple axle. The first semi-trailer of an A or C train must be equipped with a tandem axle, a triple axle or a four-axle group with a load limit of 32,000 kg (class B.44 or B.45 of the *Vehicle Load and Size Limits Regulation*).
- The **second semi-trailer** for all types of LCVs must be equipped with a tandem axle or triple axle.
- The **interaxle spacing** of the tandem axle or triple axle, as measured between the centre of the axis of rotation of each axle, must not exceed 1.85 m.

Despite the requirements listed in the second paragraph above, the first semi-trailer of an A or C train may be equipped with any combination of tandem or triple axles if it was manufactured before March 1, 1997. In such cases, the rules respecting interaxle spacing do not apply.

## ROADS WHERE LCVs ARE AUTHORIZED TO TRAVEL

LCVs are authorized to travel on only the following roads:

- ▶ divided lane highways, and highway entrance and exit ramps;
- ▶ road segments linking the entrance and exit ramps of a highway leading to opposite directions;
- ▶ roads to access a municipal industrial park, but only from a highway entrance and exit ramp for a distance of no more than 2 km;
- ▶ roads not referred to in the preceding point, but only from a highway entrance and exit ramp, for a distance of no more than 500 m, for purposes such as going to a restaurant;
- ▶ roads located within a municipal industrial park;
- ▶ Route 271, in the municipalities of Laurier-Station and Saint-Flavien, over a distance of 2 km southward from boulevard Laurier.

## ROADS WHERE LCVs ARE NOT AUTHORIZED TO TRAVEL

Even if you hold a special operating permit, you are not authorized to use exit 174 or 203 on highway 40 to enter or exit the highway.

# RESPONSIBILITIES OF SPECIAL PERMIT HOLDERS

The holder of a special permit must:

- ▶ when so requested by a carrier enforcement officer or any other peace officer and in compliance with the officer's instructions, provide the data stored or recorded by the driver monitoring system, which tracks the driver's behaviour;
- ▶ notify the Ministère des Transports du Québec of any accident or traffic jam caused by the LCV within two days of the incident;
- ▶ operate the tractor used in the LCV as an operator within the meaning of the *Act respecting owners, operators and drivers of heavy vehicles*;
- ▶ ensure that the driver of the LCV complies at all times with the driving restrictions imposed by the *Special Road Train Operating Permits Regulation* (regarding roads, hours and weather conditions).

## REQUIREMENTS

### Driver's licence

To operate the type of LCV covered by the Regulation, you must hold a Class 1 driver's licence with a T endorsement.

To obtain a T endorsement, you must:

- ▶ have held a Class 1 driver's licence for at least 5 years;
- ▶ have completed the mandatory training program for drivers of LCVs (longer than 25 m) in one of the two road transport training centres (Charlesbourg or Saint-Jérôme). For more information, contact those centres.

## Horsepower and speed

The toughest situations when driving an LCV often have to do with road conditions. Bumps, holes and ruts in the road can cause a rear semi-trailer to weave back and forth, with the risk of causing the vehicle to overturn.

To take into account the extra large size of LCVs, their stability and the layout of roads, the Regulation sets a specific speed limit for LCVs. To safeguard other road users, the Regulation also requires LCV drivers to maintain a certain distance from other vehicles. You must:

- ▶ travel at a maximum speed of 90 km/h;
- ▶ maintain a distance of at least 150 m from any road vehicle ahead of you, except where you have to pass. In general, this is an adequate distance to enable you to brake safely and come to a stop with no problem.

As a safety precaution, you should maintain an even greater distance between your own vehicle and other vehicles when weather or road conditions so require.

The best way to reduce hazards related to road conditions is to choose the right cruising speed. The faster you drive, the less time you have to observe the road. You also have less time to spot or anticipate hazards and make the necessary evasive manoeuvres.

To help you maintain a reasonable speed, especially when on an uphill grade or when gradually coming up to cruising speed, the *Special Road Train Operating Permits Regulation* requires a tractor to have a minimum 1 HP per 180 kg of total loaded mass, which represents 375 HP for a vehicle combination with a total loaded mass of 67,500 kg.

## Requirements respecting driving days and hours

LCV drivers are prohibited from:

- ▶ driving on December 26 or statutory holidays<sup>3</sup>;
- ▶ travelling on roads where LCVs are not authorized to operate;
- ▶ driving on highways from Monday to Friday:
  - ▷ from 6:30 a.m. to 9:00 a.m. and from 3:30 p.m. to 6:00 p.m. in the city of Québec,
  - ▷ from 5:30 a.m. to 9:30 a.m. and from 3:00 p.m. to 7:00 p.m. on the island of Montréal.

## Weather conditions

For safety reasons, LCV drivers must operate their vehicle only where:

- ▶ visibility is clear for a distance of 500 m or more;
- ▶ the roadway is free of snow and ice.

LCVs may be operated year round. However, during winter months (from December 1 to February 29), additional rules apply to both the holders of special road train operating permits and LCV drivers.

## Transportation of dangerous substances

The transportation of dangerous substances is prohibited in an LCV if the quantity of dangerous substances requires the display of safety mark placards.

<sup>3</sup> Statutory holidays are set out in section 61 of the *Interpretation Act*.

# SELF-EVALUATION EXERCISES



## Theoretical Exercises

### True or false

---

1. Indicate whether the following statements are true or false.

	True	False
1. Anyone who holds a Class 1 driver's licence can drive an LCV.	<input type="checkbox"/>	<input type="checkbox"/>
2. A special travel permit is required to drive an LCV.	<input type="checkbox"/>	<input type="checkbox"/>
3. The authorized maximum total loaded mass for an LCV is 67,500 kg.	<input type="checkbox"/>	<input type="checkbox"/>
4. The maximum speed the driver of an LCV is authorized to travel is 90 km/h.	<input type="checkbox"/>	<input type="checkbox"/>
5. LCVs can operate at any time, except during slippery road conditions.	<input type="checkbox"/>	<input type="checkbox"/>

Answers at the end of the guide.





# DRIVING AND OFF-DUTY TIME FOR HEAVY VEHICLE DRIVERS

11

---

**T**he rules concerning driving time, on-duty time and off-duty time help to limit the fatigue that heavy vehicle drivers may experience. Drivers who are tired pose a hazard to their own safety and that of other road users.

These standards are set forth in the *Regulation respecting the hours of driving and rest of heavy vehicle drivers*. The Regulation has two major goals:

- ▶ to enable heavy vehicle drivers to have a minimum number of hours of rest before taking to the road;
- ▶ to establish the maximum amount of driving time and on-duty time beyond which drivers are required to stop driving.

# FATIGUE

Regulatory control alone cannot eliminate the risk of accidents due to fatigue. A number of factors contribute to driver fatigue and may vary from one driver to another. Some of the main factors are:

- ▶ the time of day;
- ▶ the number of hours without sleep;
- ▶ working irregular schedules;
- ▶ the presence of a sleep disorder and an accumulated “sleep debt”;
- ▶ the driver’s state of health;
- ▶ the workload and work practices.

You must be alert to the first signs of fatigue (frequent yawning, blinking, involuntary lane changes, delays in braking, frequently speeding up and slowing down, etc.) and avoid taking the wheel when you are tired, or else pull over in a safe location to rest as soon as you notice the signs of fatigue.

# INDIVIDUALS COVERED

The following individuals are covered by the Regulation:

- ▶ heavy vehicle drivers;
- ▶ heavy vehicle operators;
- ▶ shippers, consignees or other persons covered by certain provisions of the Regulation that apply to heavy vehicle operators.

# VEHICLES COVERED

Drivers of the following vehicles are covered by the Regulation:

- ▶ **Road vehicles with a GVWR of 4,500 kg or more**, for example:
  - ▶ trucks (including road tractors);
  - ▶ trailers and semi-trailers;
  - ▶ equipment transport vehicles (e.g. well-drilling rigs, concrete pumps, compressors, cranes mounted on a truck chassis).
- ▶ **Road vehicle combinations including at least one vehicle with a GVWR of 4,500 kg or more.**
- ▶ **The following road vehicles, regardless of their GVWR:**
  - ▶ buses and minibuses (other than those used for urban transit);
  - ▶ tow trucks;
  - ▶ vehicles carrying dangerous substances that require the display of safety mark placards.

# EXEMPT VEHICLES

Drivers and operators of the following heavy vehicles are exempted from the regulatory requirements governing on-duty and off-duty time:

- ▶ A **heavy vehicle used for an entire day by an individual for personal purposes**, that is, for purposes other than commercial or professional, for example:
  - ▶ a vehicle with a GVWR of 4,500 kg or more (pickup truck, recreational vehicle) that is used solely for personal purposes;
  - ▶ a vehicle with a GVWR of 4,500 kg or more used for personal purposes for an entire day on Saturdays and Sundays (exempt on those days only).
- ▶ A **heavy vehicle** used during part of the day by an individual for personal purposes, that is, for purposes other than commercial or professional, is exempt for the **first 75 km travelled** in a day, where the following conditions have been met:
  - ▶ The vehicle has been unloaded and trailers have been unhitched.
  - ▶ The driver has recorded the odometer reading in the daily log at the beginning and at the end of the period during which the vehicle is used for personal purposes.
  - ▶ The driver is not the subject of an out-of-service order.

Thus, a driver whose home terminal is at the establishment uses a tractor to return home after a day of work; this driving time is considered to be off-duty for the first 75 km travelled. If the distance exceeds 75 km, the time to cover this additional distance will be deemed hours of driving.

- ▶ An **emergency vehicle** (e.g. ambulance, fire department road vehicle, response vehicle).
- ▶ A **heavy vehicle** that is used when it is required by an emergency service or in the event of a disaster.
- ▶ A **tool vehicle**, which is a road vehicle, other than a vehicle mounted on a truck chassis, manufactured to perform work, the work station of which is an integral part of the driver's cab (e.g. grader, road roller, fork lift, back loader).
- ▶ A **farm tractor** or **farm machine** within the meaning of the *Regulation respecting the registration of road vehicles*.
- ▶ A **farm trailer** within the meaning of the *Regulation respecting safety standards for road vehicles*, belonging to a farmer.
- ▶ A **bus** used for urban transit provided by a public transit corporation or under a contract with a public transit body, an intermunicipal commission or board, a municipality or group of municipalities.
- ▶ A **vehicle with a GVWR of less than 4,500 kg or road vehicle combination in which each vehicle has a GVWR of less than 4,500 kg**, if it is transporting dangerous substances not requiring the display of safety mark placards, except for minibuses and tow trucks.
- ▶ A **straight-body truck with two or three axles** used to transport the primary products of a farm, forest or fishery, if the operator of the truck is the producer of the products (e.g. a potato grower who makes deliveries). The exemption also applies to a vehicle that is used to return to an operator's place of business after making such a trip; in the latter case, the vehicle must be unloaded or be carrying only goods used in running the farm, forest or fishery operation.

The table below lists a few examples of farm, forest and fishery products and indicates whether the goods are defined as a primary product.

Types of goods	Defined as a primary product?	
	Yes	No
Farm		
▶ Live cattle	x	
▶ Sides of beef		x
▶ Eggs	x	
▶ Vegetables	x	
▶ Homogenized milk		x
▶ Flowers in flats	x	
Forestry		
▶ Trees with branches removed		x
▶ Trees cut into logs		x
▶ Trees sawed into lengths		x
▶ Shrubs for planting	x	
▶ Christmas trees	x	
Fishery		
▶ Cooked lobsters		x
▶ Cut and gutted fish		x
▶ Dead fish (whole raw)	x	
▶ Live fish	x	

### VERY IMPORTANT

Anyone who drives an exempt vehicle (except where the vehicle is being used for personal purposes) is required to count these hours as on-duty time when driving a heavy vehicle covered by the Regulation. For example, a bus driver who drives an urban transit vehicle must count the hours of on-duty time in determining whether he or she can participate in a chartered transport during the weekend.

# DEFINITIONS

To comply with the Regulation, you must be familiar with the following basic concepts:

## Adverse driving conditions

Adverse road or weather conditions that were not known to the driver or operator before the driver began driving or could not reasonably have been known to them.

## Cycle

Cycle 1 or cycle 2.

## Cycle 1

A cycle under which on-duty time is accumulated over a period of 7 days.

## Cycle 2

A cycle under which on-duty time is accumulated over a period of 14 days.

## Daily log

A document in which the driver writes all of the information about each duty status during the day. The log contains a graph grid covering a 24-hour period, along with certain mandatory information required by the Regulation.



## Day

A period of 24 hours that begins at the time designated by the operator and lasts for the duration of the driver's cycle. If no time has been specified, the period begins at midnight.

## Driver

An individual:

- ▶ who drives a heavy vehicle;
- ▶ whom an operator employs to drive a heavy vehicle;
- ▶ who has been hired to drive a heavy vehicle.

## Driving time (hours of driving)

The number of hours during which a driver is at the wheel of a heavy vehicle when the engine is running.

## Duty status

Duty status refers to one of the following periods:

- ▶ off-duty time (hours of rest), other than time spent in a sleeper berth;
- ▶ off-duty time (hours of rest) spent in a sleeper berth;
- ▶ on-duty time (hours of service), excluding hours of driving;
- ▶ driving time (hours of driving).

## Establishment

The location(s) designated by the operator as the place where daily logs, supporting documents and other records required under the Regulation are kept.

## Home terminal

The place where the driver ordinarily reports for work and any other temporary work location designated by the operator.

## Individual who supplies the services of a driver

This concept applies when an operator hires the services of a driver who is not directly employed by the operator, that is, the driver is supplied by a driver agency or another operator.

An owner-operator or broker who offers his or her own services as a driver for an operator is not considered a person who supplies the services of a driver. However, an owner-operator or broker who offers the services of drivers other than himself or herself is considered a person who supplies the services of a driver within the meaning of the *Highway Safety Code*.

## Off-duty time (hours of rest)

Any period of time other than a driver's on-duty time. Breaks, time taken for meals, holidays, vacation and time spent on a ferry are deemed to be hours of rest, provided:

- ▶ the driver has been completely relieved of all duties, responsibilities and obligations regarding the care and custody of the vehicle, its accessories and the passengers or load it may be carrying;
- ▶ throughout the downtime period in question, the driver must be free to partake in the activities of his or her choosing and be allowed to leave the location of the vehicle.

The operator is not required to issue a letter to a driver (also called a "release letter") authorizing the driver to enter time taken for meals or other breaks as off-duty time.

## Off-duty time (hours of rest) in the sleeper berth of a vehicle

The amount of time actually spent resting in the sleeper berth of a heavy vehicle.

## On-duty time (hours of service)

The period of on-duty time begins when the driver starts work and includes the time during which the driver is required to remain available at the work site. It ends when the driver stops work or is relieved of his or her duties by the operator. On-duty time includes the hours of driving and the time a driver spends performing the following activities:

- ▶ inspecting, servicing, repairing, conditioning or starting a heavy vehicle;
- ▶ writing reports;
- ▶ travelling in a heavy vehicle as a co-driver, except for time spent in the sleeper berth;
- ▶ participating in loading and unloading a heavy vehicle;
- ▶ inspecting and checking the load of a heavy vehicle;
- ▶ waiting for an assignment;
- ▶ waiting:
  - ▶ for a heavy vehicle to be serviced, loaded or unloaded,
  - ▶ for a heavy vehicle or its load to be inspected,
  - ▶ during an inspection of papers or verification of the driver;
- ▶ waiting at an en-route point because of an accident or other unforeseen occurrence;
- ▶ performing any other work at the request of the operator.

A driver who is waiting at the home terminal to begin a trip must consider this period as on-duty time. If the waiting period takes place at home, it is considered off-duty time, even if a driver is paid for this period.

## Radius of 160 km

A radius of 160 km in airline distance from the driver's home terminal. The radius is plotted using a map.

## Sleeper berth

An area of a heavy vehicle designed for use as a sleeping compartment that is located within the cab interior or immediately beside the cab and complies with the provisions of the Regulation (see Appendix 1).

## Work shift

The time between two periods of at least 8 consecutive hours of off-duty time.



# GENERAL RULES

When planning a schedule, a driver must comply with the requirements of the following reference periods:

## 14 days

Regardless of which cycle is followed, in order to be allowed to drive, a driver must have taken at least 24 consecutive hours of off-duty time during the 14 days preceding the current day.

January 2014						
SUN	MON	TUES	WED	THURS	FRI	SAT
		1 REST	2 ✓	3 ✓	4 ✓	5 ✓
6 ✓	7 ✓	8 ✓	9 ✓	10 ✓	11 ✓	12 ✓
13 ✓	14 ✓	15 ✓	16 REST	17 ✓	18 ✓	19 ✓
20 ✓	21 ✓	22 ✓	23 ✓	24 ✓	25 ✓	26 ✓
27 ✓	28 ✓	29 ✓	30 ✓	31 REST Today		

## Cycles

A driver follows cycle 1 or cycle 2.

**If the driver is following cycle 1:**

- ▶ **No driving is allowed** after the driver has accumulated **70 hours of on-duty time** over a period of **7 consecutive days**.

The following is an example over a period of 3 days:

SUN	MON	TUES	WED	THURS	FRI	SAT
0 h	1st 13 h	2nd 8 h	3rd 12 h	4th 10 h	5th 11 h	6th 0 h
7th ? h						

Accumulated  
Days 1-6:  
54 hours  
Remaining:  
70-54 =  
16 hours

SUN	MON	TUES	WED	THURS	FRI	SAT
0 h	13 h	1st 8 h	2nd 12 h	3rd 10 h	4th 11 h	5th 0 h
6th 3 h	7th ? h					

Accumulated  
Days 1-6:  
44 hours  
Remaining:  
70-44 =  
26 hours

SUN	MON	TUES	WED	THURS	FRI	SAT
0 h	13 h	8 h	1st 12 h	2nd 10 h	3rd 11 h	4th 0 h
5th 3 h	6th 10 h	7th ? h				

Accumulated  
Days 1-6:  
46 hours  
Remaining:  
70-46 =  
24 hours

If the driver is following cycle 2:

- ▶ **No driving is allowed** after the driver has accumulated:
  - ▶ **120 hours of on-duty time** over a period of **14 consecutive days**;
  - ▶ **70 hours of on-duty time** without having taken at least **24 consecutive hours of off-duty time**.

Here is an example:

SUN	MON	TUES	WED	THURS	FRI	SAT
0 h	1st 10 h	2nd 10 h	3rd 10 h	4th 10 h	5th 10 h	6th 10 h
7th 0 h	8th 8 h	9th 9 h	10th 8 h	11th 8 h	12th 8 h	13th 8 h
14th ?h						

**Condition 1 - No driving is allowed after a driver has accumulated 120 hours of on-duty time over a period of 14 consecutive days.**

Hours of on-duty time accumulated:

- ▶ 109 hours (days 1 to 13)

Hours of driving remaining:

- ▶  $120 - 109 = 11$  hours (day 14)

**Condition 2 - No driving after 70 hours of on-duty time without having taken 24 consecutive hours of off-duty time.**

Hours of on-duty time accumulated:

- ▶ 49 hours (days 8 to 13)

Hours of driving remaining:

- ▶  $70 - 49 = 21$  hours (day 14)

In order to meet both conditions, the driver must not drive **more than 11 hours** on the 14th day.

## Beginning a cycle or switching cycles

A driver **can terminate** the current cycle, **begin** a new cycle or **switch from one cycle to the other**, provided the driver takes the following amount of off-duty time:

- ▶ at least 36 consecutive hours of off-duty time if the driver is following cycle 1;
- ▶ at least 72 consecutive hours of off-duty time if the driver is following cycle 2.

After having taken this off-duty time, the driver begins a new cycle; the hours of on-duty time cycle are then reset to zero and begin to accumulate again.

## Work shift

A work shift is the time **between two periods of at least 8 consecutive hours of off-duty time**. A new work shift begins after a period of at least 8 consecutive hours of off-duty time. The hours of off-duty time cannot be taken on board the heavy vehicle while it is stopped, unless the driver spends them in the sleeper berth.

## Work shift requirements

From the time a work shift begins, the driver is **prohibited from driving after**:

- ▶ accumulating **13 hours of driving time**;
- ▶ accumulating **14 hours of on-duty time**;
- ▶ **16 hours** have elapsed.



Here is an example of a work shift that complies with the Regulation:

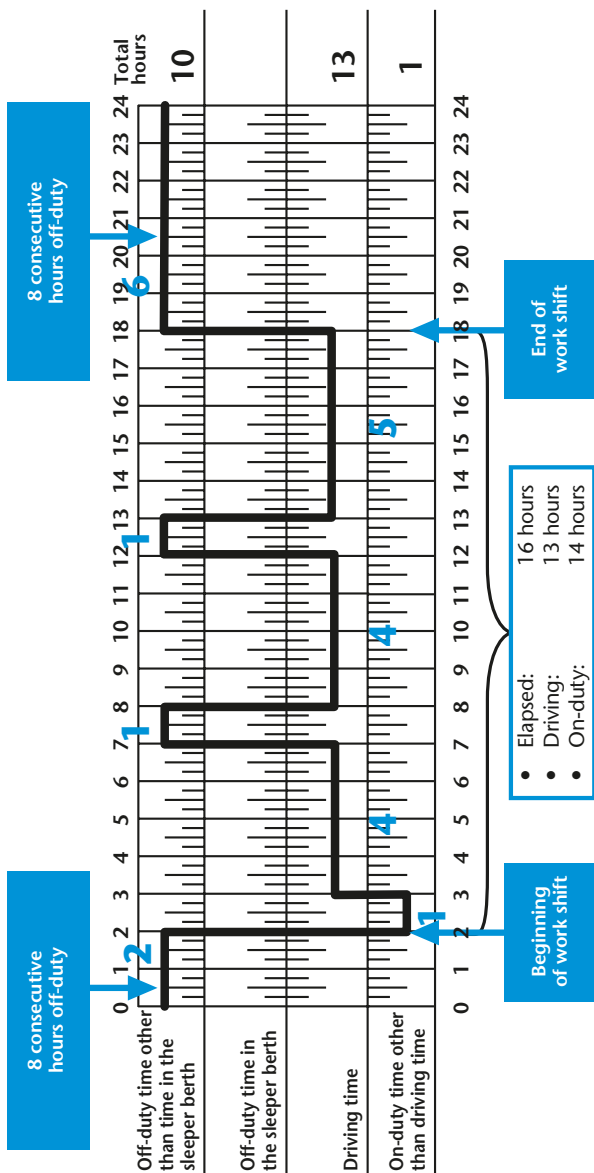

Here is an example of a work shift that **does not comply** with the Regulation:

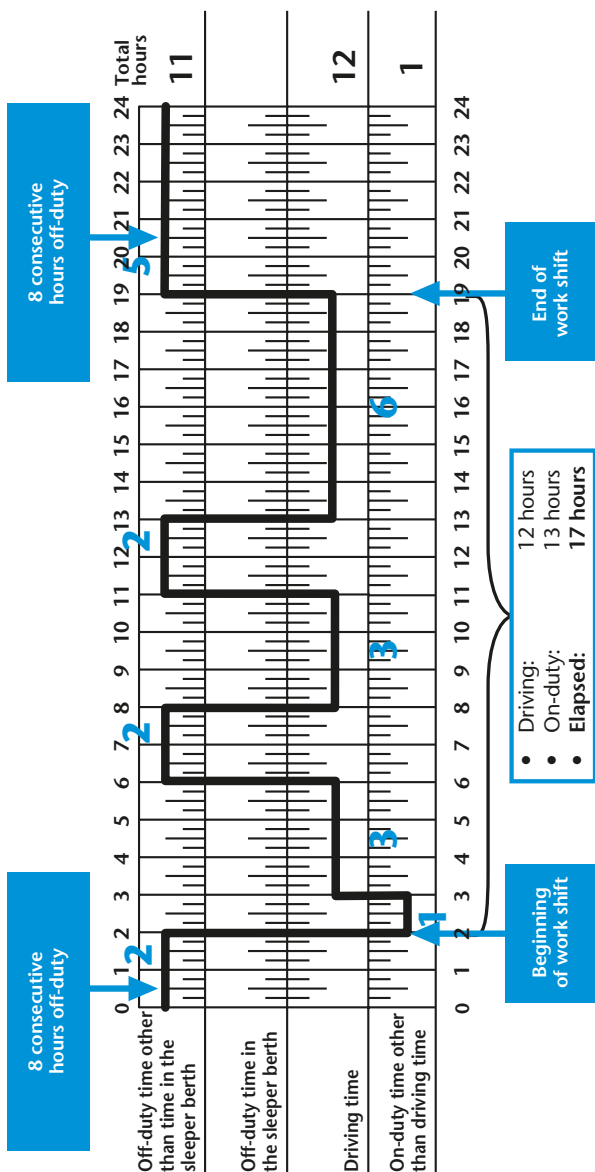

## Day

A day is a period of 24 hours that corresponds to a daily log. During a cycle, the day always begins at the same time. If the driver wishes to change the time the day begins, a new cycle must be started.

**The time the day begins may be different from the time the driver begins a work shift.** For example, the day may begin at midnight and the work shift may begin at 7:00 a.m.

## Daily requirements

The driver must take at least **10 hours of off-duty time** in a day. This time must include at least 2 hours of off-duty time that are not part of the period of **8 consecutive hours of off-duty time** required before beginning a work shift, and it may be split up into breaks of not less than 30 minutes.

During a day, a driver **must stop driving** after accumulating:

- ▶ **13 hours** of driving time; or
- ▶ **14 hours** of on-duty time.

Here is an example of a work shift that **complies** with the Regulation:

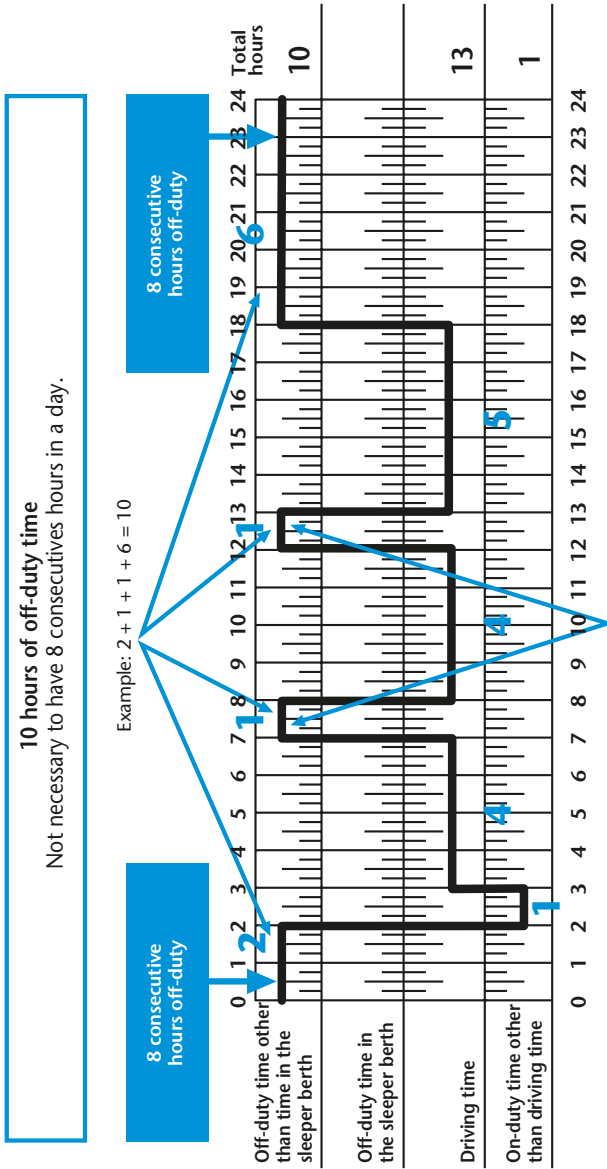

2 hours of off-duty time that are not part of the required period of 8 consecutive hours of off-duty time

Here is an example of a work shift that **does not comply** with the Regulation:

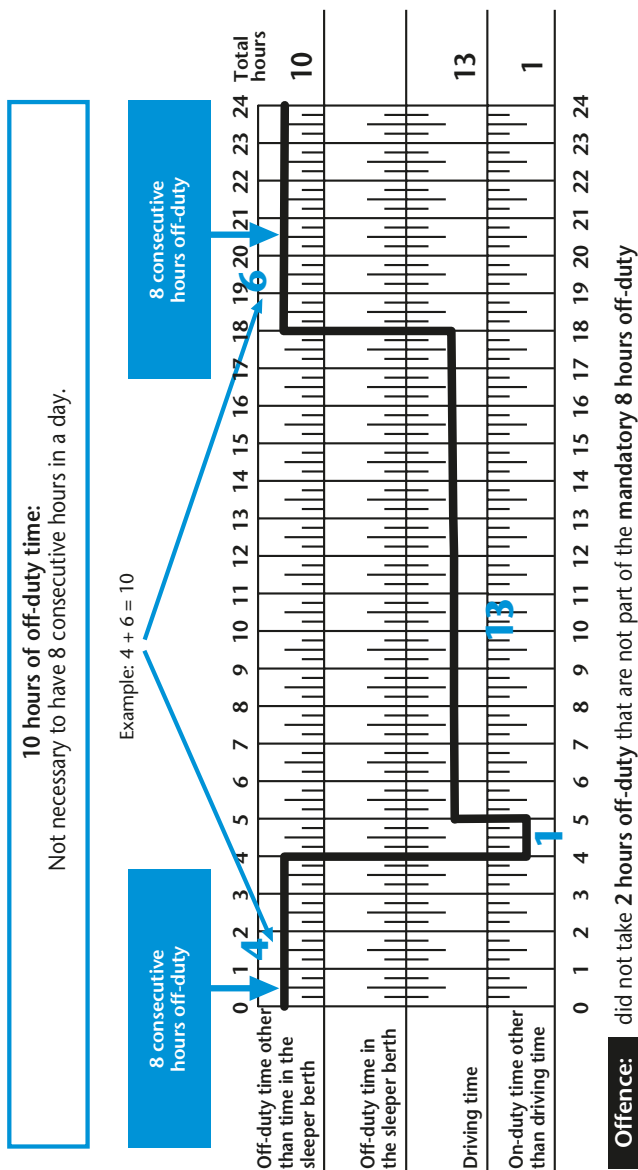

## “Work shift” and “day” combination

If a work shift overlaps two days, you must comply with the rules that apply to a day AND the rules that apply to a work shift.

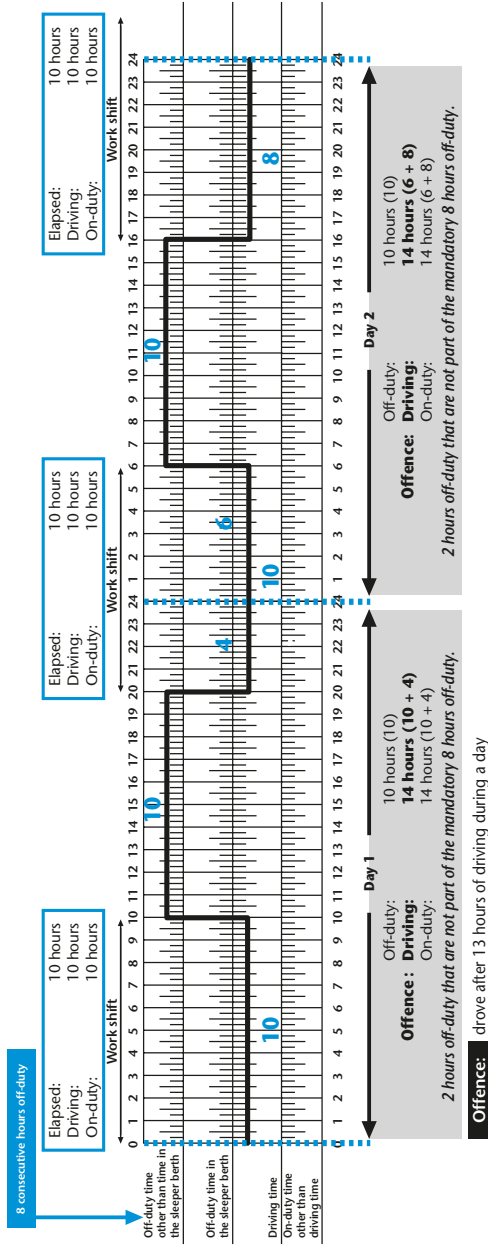

# SPECIAL SITUATIONS

## Deferral of daily off-duty time

A driver can extend driving time or on-duty time by no more than 2 hours in a day, provided the 2 hours of off-duty time are deferred to the following day and the following conditions are met:

- ▶ The driver does not split his or her daily hours of off-duty time in a sleeper berth.
- ▶ The hours of off-duty time deferred are not part of the mandatory 8 consecutive hours of off-duty time.
- ▶ The hours of off-duty time deferred are added to the 8 consecutive hours of off-duty time taken in the second day.
- ▶ The total hours of off-duty time taken during the 2 days are at least 20.
- ▶ The total hours of driving time accumulated during the 2 days are no more than 26.
- ▶ The driver states in the “Remarks” section of the daily log that he or she is deferring daily hours of off-duty time and indicates whether the deferral applies to day 1 or day 2 of the deferral period.

### VERY IMPORTANT:

A deferral of hours of off-duty time allows the number of hours of driving to be extended to a maximum of 15 or the number of hours of on-duty time to be extended to a maximum of 16 in a single day. However, the hours deferred cannot be used to extend the hours of driving and hours of on-duty time in a work shift.

11

Here is an example of deferral of daily hours of off-duty time that complies with the Regulation:

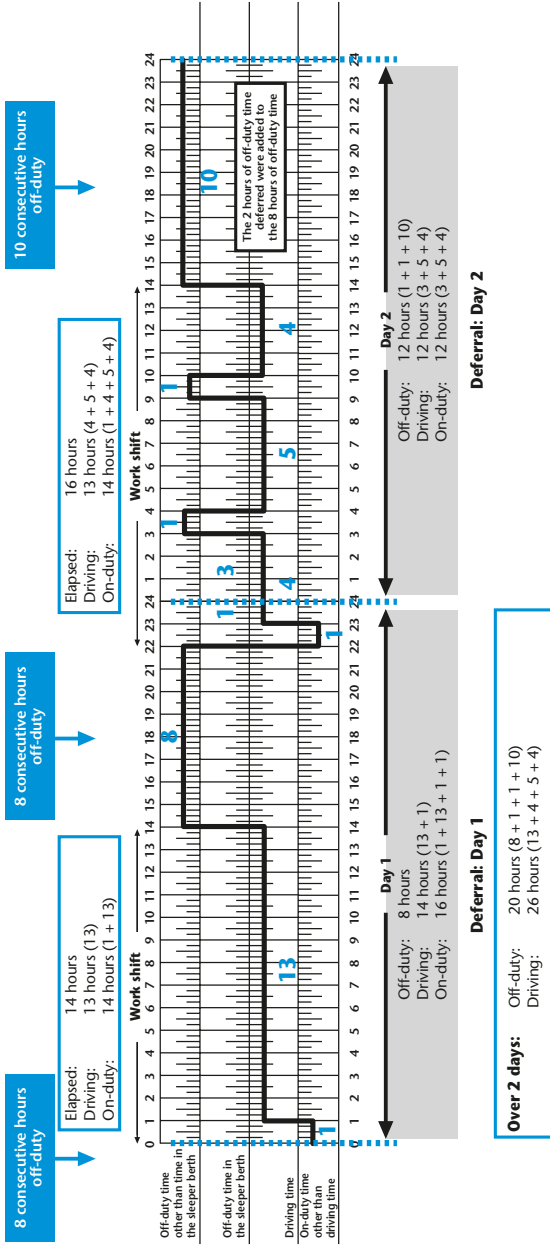



Here is an example of deferral of daily hours of off-duty time that **does not comply** with the Regulation:

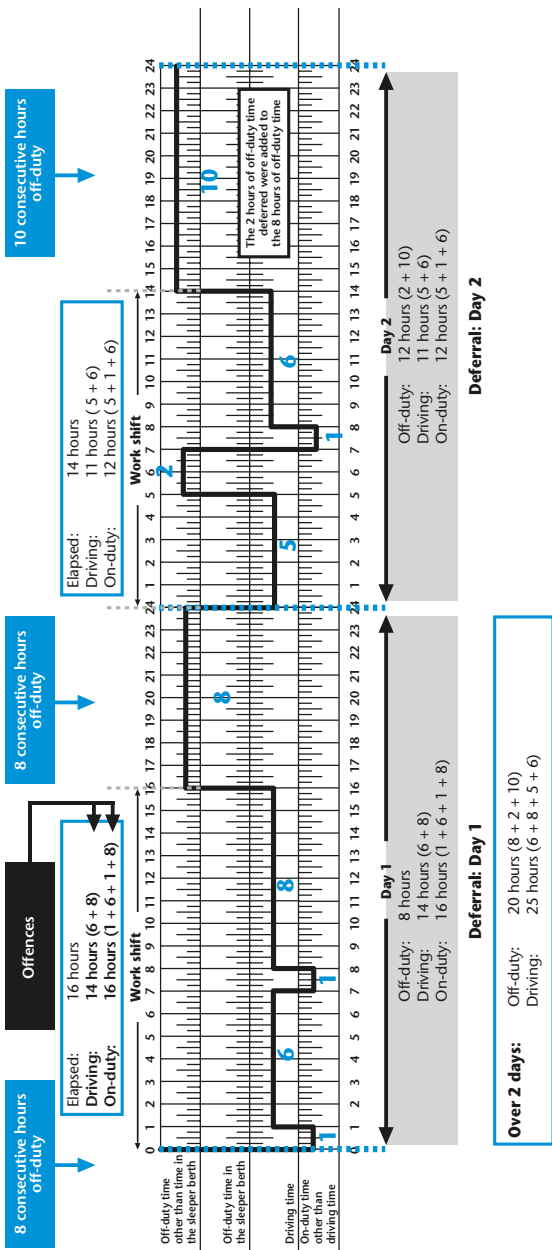

**Offences:** drove after 13 hours of driving since the beginning of the work shift  
drove after 14 hours of driving since the beginning of the work shift

# SPLITTING OF OFF-DUTY TIME IN A SLEEPER BERTH

A driver who is **travelling alone** can use the sleeper berth in a vehicle to split hours of off-duty time **into two periods**, provided the following conditions are met:

- ▶ The hours of off-duty time are not deferred to the following day.
- ▶ Each period of off-duty time is **at least 2 hours long**.
- ▶ The total of both periods is **at least 10 hours**.
- ▶ The hours of off-duty time are spent in the sleeper berth.
- ▶ The driver must take **at least 10 hours** of off-duty time and **stop driving** after accumulating **13 hours of driving or 14 hours of on-duty time** in one day.
- ▶ Before and after each period of off-duty time that is used for splitting, the driver **must stop driving** after accumulating:
  - ▶ **13 hours** of driving time, or
  - ▶ **14 hours** of on-duty time.
- ▶ The driver must **stop driving after 16 hours** have elapsed.



**Drivers travelling as a team** can use the sleeper berth of their vehicle to split hours of off-duty time **into two periods**, provided the following conditions are met:

- ▶ The hours of off-duty time are not deferred to the following day.
- ▶ Each period of off-duty time is at least **4 hours** long.
- ▶ The total of both periods of off-duty time is at least **8 hours**.
- ▶ The hours of off-duty time are spent in the sleeper berth.
- ▶ The driver takes an extra **2 hours of off-duty time** in addition to the **8 hours of split off-duty time**.
- ▶ The driver must take **at least 10 hours of off-duty time and stop driving** after accumulating **13 hours of driving or 14 hours of on-duty time** in one day.
- ▶ Before and after each period of off-duty time that is used for splitting, the driver **must stop driving** after accumulating:
  - ▶ **13 hours** of driving time, or
  - ▶ **14 hours** of on-duty time.
- ▶ The driver must **stop driving after 16 hours** have elapsed.

Here is an example of splitting off-duty hours in a sleeper berth that **does not comply** with the Regulation in the case of a team of drivers:

**Daily requirements:**

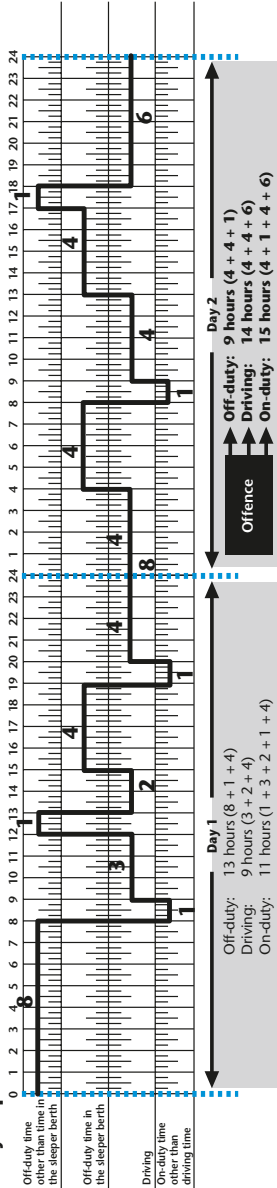

**Splitting of off-duty hours in the sleeper berth:**

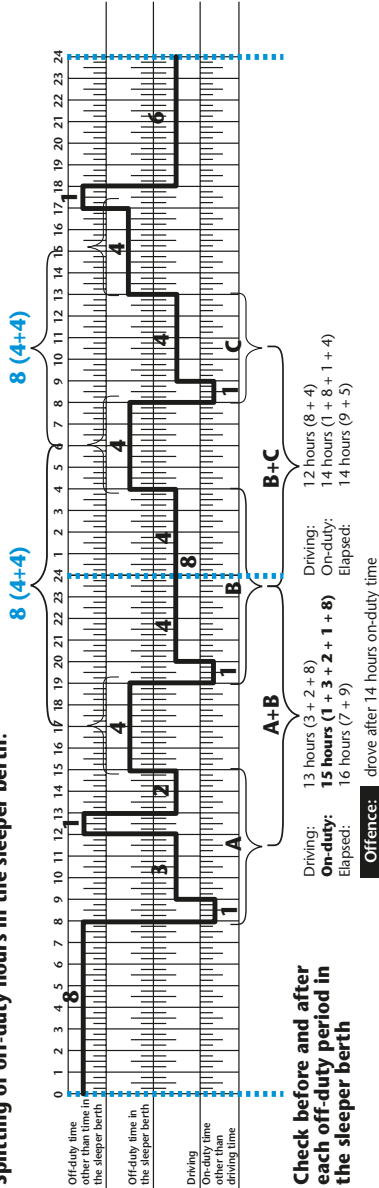

**Check before and after each off-duty period in the sleeper berth**

## Emergencies

In the event of an emergency, the driver may extend the hours of driving time and the hours of on-duty time in order for the occupants of the heavy vehicle to reach a safe destination, as well as to protect the safety of other road users or the security of the heavy vehicle and its load.

Such actions are permitted in exceptional circumstances where the driver must take immediate action. The situation is no longer deemed an emergency or a hazard once the driver has reached the nearest safe haven for the vehicle or for the passengers or goods being transported. There is no limit to the number of hours in this case.

## Adverse driving conditions

If, during a trip, the driver encounters adverse driving conditions that cause a delay, the hours of driving time and on-duty time may be extended by 2 hours provided:

- ▶ the driver has not taken an extra 2 hours of off-duty time in addition to the 8 consecutive hours of off-duty time;
- ▶ the trip could have been completed under **normal driving conditions**.

Adverse driving conditions are exceptional circumstances that could not have been predicted by or known to the driver or dispatcher at the time the trip began based on the information available at that time. Furthermore, such unforeseen circumstances must be related to road, weather or traffic conditions.

For example, a traffic jam due to an unforeseen circumstance, such as an accident that occurred after the driver's departure, falls within the definition of an unforeseen road or traffic condition. However, a traffic jam during rush hour or a mechanical failure is not an unforeseen road or traffic condition. Icy road conditions or a snowstorm is an unforeseen road or traffic condition, provided it was not known to the driver or dispatcher (or could not reasonably have been known to them) prior to the vehicle's departure.

## Towing

The driver of a tow truck may exceed the hours of driving time and hours of on-duty time and reduce the hours of off-duty time if so required in order to complete the towing of a vehicle stopped on a public road and return to the home terminal, provided the following conditions are met:

- ▶ The driver can reach the location of the breakdown or accident under normal road conditions in compliance with the hours prescribed by the Regulation.
- ▶ The driver does not travel more than 160 km from the towing location to the home terminal.

## Winter road maintenance

A driver is allowed to drive up to 15 hours per work shift where necessary to protect the public's safety, plow a public road due to snow accumulation, or spread abrasives or ice melting products. The driver can choose one of two options.

### Option 1

Defer 2 hours of off-duty time that are not part of the mandatory 8 consecutive hours and add them to the 8 consecutive hours of off-duty time taken at the end of the first, second or third shift. Two hours of off-duty time can be deferred for two consecutive work shifts.

In the example given below, the driver chose to drive for 15 hours over the course of two consecutive work shifts and to add the hours of off-duty time at the end of the third work shift.

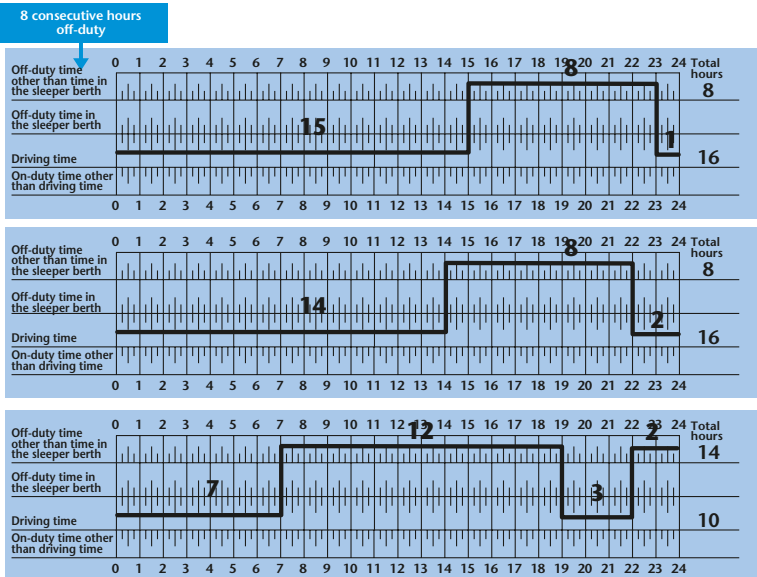

**Off-duty time** over 3 days: **30 hours** (8 + 8 + 12 + 2)  
**Driving** over 3 work shifts: **39 hours** (15 + 1 + 14 + 2 + 7)



## Option 2

**Defer 2 of the 8 consecutive hours of off-duty time** taken at the end of the work shift and **2 hours of off-duty time** not included in the mandatory 8 consecutive hours and **add them to the 8 consecutive hours of off-duty time** taken at the end of the second work shift. This time can be deferred for only one work shift.

Once the driver has chosen one option, the other option may not be used until after the end of the third work shift. Regardless of which option is chosen, the driver must comply with the following conditions:

- ▶ The driver must stop driving after accumulating 16 hours of on-duty time or after 16 hours have elapsed since the time the work shift began.
- ▶ The driver has taken at least 8 consecutive hours of off-duty time before beginning the first work shift.
- ▶ The driver does not split the daily hours of off-duty time in the sleeper berth.
- ▶ The driver takes a total of at least 30 hours of off-duty time during the **3-day** period encompassing the 3 work shifts.
- ▶ The total hours of driving during the **3 work shifts** does not exceed 39.
- ▶ The driver states in the daily log that he or she is deferring off-duty hours and indicates which option is chosen and whether the deferral applies to the first, second or third work shift.

In the example given below, the driver drove for 15 hours during a work shift and reduced the number of off-duty hours at the end of the first work shift to 6 consecutive hours. The driver must therefore add the number of off-duty hours not taken to the 8 consecutive hours of off-duty time taken at the end of the second work shift; the driver is therefore required to take 12 consecutive hours of off-duty time.

8 consecutive hours  
off-duty

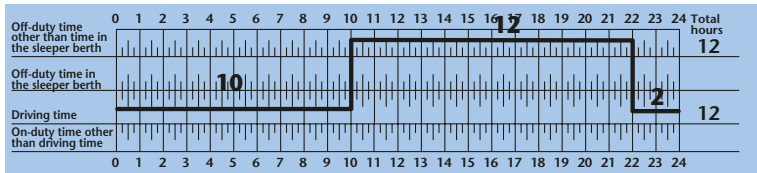
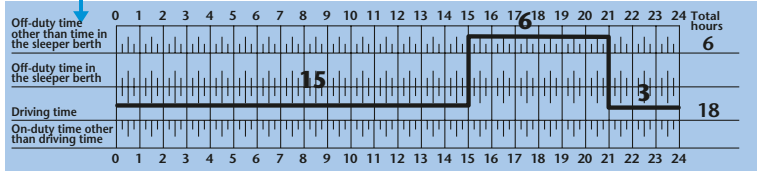

**Off-duty time** over 3 days: **30 hours** (6 + 12 + 12)  
**Driving over** 3 work shifts: **39 hours** (15 + 3 + 10 + 2 + 9)

## Ferries

A driver who travels on a ferry where the expected duration of the trip is longer than 5 hours is not required to take 8 consecutive hours of off-duty time, provided the following conditions are met:

- ▶ The driver takes a total of at least 8 hours of off-duty time in the sleeper berth while waiting to board, in a cabin on the ferry and in a location no more than 25 km from the disembarkation point.
- ▶ The driver records these hours in the daily log as off-duty hours in the sleeper berth.
- ▶ The driver keeps the receipt of payment for the ferry service and cabin fees.

# DAILY LOG

## Requirements

The driver must fill out a daily log indicating the time devoted to each duty status during the day and recording the time based on local time at the driver's home terminal.

**Note: Daily logs using the terms “hours of rest” and “hours of service” are also acceptable.**

Example of a daily log that **complies** with the Regulation:

Daily log	07 12 2008 Day Month Year	Start of work shift (if different than midnight)	195 648 Odometer reading Start of day	196 413 Odometer reading End of day	765 Miles/km driven	
<input checked="" type="checkbox"/> Cycle 1: 7 days <input type="checkbox"/> Cycle 2: 14 days	L-12345 Licence plate number of heavy vehicle		Registration certificate unit number			
XYZ Transport inc. Operator	1464, boul. de la Sécurité, Québec G1K 8J6 Operator's main business address		1464, boul. de la Sécurité, Québec G1K 8J6 Home terminal address			
<b>Duty status</b>						
Total hours						
Off-duty time other than time in the sleeper berth	0 1 2 3 4 5 6 7 8 9 10 11 12 13 14 15 16 17 18 19 20 21 22 23 24					10
Off-duty time in the sleeper berth	[Bar chart showing 4h, 4h, 5h, 5h blocks]					13
Driving time	[Bar chart showing driving periods]					1
On-duty time other than driving time	[Bar chart showing on-duty periods]					24
Remarks:	Québec, QC    Trois-Pistoles, QC    Cap-Chat, QC    Percé, QC					
	Jean Prudent Driver's name			Co-driver's name		
	Jean Prudent Driver's signature					

- Beginning of the day
- During the day
- At the end of the day

The starting time on the log is also the beginning of the day. Here is how to fill out a daily log:

### **Between the beginning of the day and the first period of driving, the driver enters the following information:**

(see the entries in black on the daily log shown on page 323)

- ▶ the date;
- ▶ the driver's name;
- ▶ the name of the co-driver(s) when working in a team;
- ▶ the time at which the day starts, if it is not at midnight;
- ▶ the cycle that the driver is following;
- ▶ the licence plate number of the motor vehicle or the unit number indicated on the vehicle registration certificate;
- ▶ the motor vehicle's odometer reading;
- ▶ a line on the grid showing the time devoted to each duty status between the beginning of the day and the time the driver begins driving;
- ▶ the operator's name and the address of the home terminal and the establishment of the operator who employs or has hired the driver;
- ▶ in the space reserved for remarks in the log:
  - ▶ the number of hours of off-duty and on-duty time accumulated for each day during which the driver was not required to fill out a log over the course of the 14 days that preceded the start of the work day,
  - ▶ the reasons for exceeding the permitted number of hours or for deferring off-duty hours, if applicable.

This example shows that the driver has drawn, in the "Off-duty time other than time in the sleeper berth" section, a line from midnight to 2:00 a.m. and then a line in the "On-duty time other than driving time" section from 2:00 a.m. to 3:00 a.m. In the "Remarks" section, the driver has indicated the place of departure as Québec.

## During the day, the driver must:

(see the entries in pale blue on the daily log shown on page 323)

- ▶ Fill out the log as follows:
  - ▶ use a solid line to indicate the hours devoted to each duty status during the day,
  - ▶ indicate the name of the municipality (or if that is not possible, the road and distance marker in kilometres or miles) and the province, territory or state where the change of duty status took place,
  - ▶ if necessary, indicate the reasons for exceeding the number of hours in the “Remarks” section.
- ▶ Enter:
  - ▶ the name and address of the home terminal and the establishment of any other operator who employs or hires the driver’s services,
  - ▶ the licence plate number or the unit number indicated on the vehicle registration certificate, along with the odometer reading of any other motor vehicle the driver has used.

The above example shows that the driver arrived in Trois-Pistoles at 7:00 a.m. and made a rest stop there until 8:00 a.m.

**IMPORTANT: A line must be drawn to indicate each time the driver makes a change in duty status.**

In the “Remarks” section, the driver must always indicate the place where each change of duty status occurs.

## At the end of the day, the driver must enter:

(see the entries in dark blue on the daily log shown on page 323)

- ▶ the total number of hours devoted to each duty status (rest, sleeper berth, driving, work);
- ▶ the distance travelled that day, after deducting the distance travelled for personal reasons using the vehicle;
- ▶ the odometer reading at the end of the day;
- ▶ his or her signature.

## Exemptions

A driver who meets all of the following conditions is not required to fill out a daily log:

- ▶ The driver operates the vehicle within a radius of 160 km of the home terminal.
- ▶ The driver returns to the home terminal each day to take at least 8 hours of off-duty time.
- ▶ The driver's vehicle is not covered by a permit for exemption from the hours of driving and off-duty time.
- ▶ The operator **meets one of the following requirements**:
  - ▶ The operator keeps up-to-date records that indicate, for each day, the time devoted to each duty status by the driver, the cycle the driver is following, the starting time and end time of each duty status, the total number of hours devoted to each duty status and, if applicable, the reasons for exceeding the permitted number of hours or for deferring off-duty hours.
  - ▶ The operator keeps a written record of the date and time a day begins (unless it begins at midnight), the cycle the driver is following, the starting time and end time of the driver's work shift, and the total number of the driver's hours of on-duty time during the day, provided all of the following conditions are met:

- ▶ The work shift **begins and ends the same day**.
- ▶ The work shift lasts **13 hours or less**.
- ▶ The length of the off-duty period before and after the work shift is **at least 11 consecutive hours**.

**IMPORTANT:** Even if you are a driver who has been exempted from filling out a daily log, you are still required to comply with the prescribed number of hours of driving, on-duty time and off-duty time.

## DETAILS OF THE DAILY LOG

### Trip with two drivers

Every heavy vehicle driver has a personal daily log. If there are two drivers for the same trip, each driver must therefore complete his or her own personal daily log and enter the name of the relief driver.

### Change of day

If the driver is driving at the time when one day changes to the next, he or she must record or memorize the odometer reading at that time and enter this information in the daily log at the next stop. The driver uses this information to calculate the distance travelled during the day just ended and to enter the odometer reading for the day just beginning in the new daily log.

### Multiple stops

Some trips require drivers to make multiple stops in a municipality within a short period of time in order to pick up or deliver goods. In such cases, recording the duty status on the grid can become complicated.





## Days off

Days off must be entered in the daily log. Various methods can be used to simplify the task of entering this information. The two methods outlined below are the most frequently used. Let us suppose that a driver takes 2 consecutive days off, October 4 and 5:

▶ **1st method:**

Using one copy of the daily log, the driver draws an unbroken line covering 24 hours in the “Off-duty time other than time in the sleeper berth” section. In the “Remarks” section, the driver writes “Off October 4 and 5” and then signs the daily log.

▶ **2nd method:**

Assuming the driver returns to work on October 6, he or she must fill out a log for that day. Before starting the work shift for October 6, the driver can write “Off October 4 and 5” in the “Remarks” section of the log.

## Drivers who occasionally travel beyond the 160 km radius

Drivers may occasionally be required to travel beyond the 160 km radius, in which case they must fill out a daily log for the day concerned. Any driver who was not otherwise subject to the requirement to keep a daily log immediately before that day must enter, in the “Remarks” section of the log for that day, the number of hours of off-duty and on-duty time accumulated for each day during the preceding 14 days the driver was not required to keep a log. Here is an example:

Daily log	07 12 2008 Day Month Year	195 648 Start of work shift (if different than midnight) Start of day	Odometer reading Start of day	Odometer reading End of day	Miles/km driven									
<input checked="" type="checkbox"/> Cycle 1: 7 days <input type="checkbox"/> Cycle 2: 14 days	L-12345 Licence plate number of heavy vehicle		Registration certificate unit number											
XYZ Transport inc. Operator	1464, boul. de la Sécurité, Québec G1K 8J6 Operator's main business address		1464, boul. de la Sécurité, Québec G1K 8J6 Home terminal address											
<b>Duty status</b>					<b>Total hours</b>									
0 1 2 3 4 5 6 7 8 9 10 11 12 13 14 15 16 17 18 19 20 21 22 23 24														
Off-duty time other than time in the sleeper berth	[Bar chart showing off-duty time]													
Off-duty time in the sleeper berth	[Bar chart showing off-duty time in sleeper berth]													
Driving time	[Bar chart showing driving time]													
On-duty time other than driving time	[Bar chart showing on-duty time other than driving time]													
Remarks:	Québec, QC      Montréal, QC      Québec, QC													
	Jean Prudent Driver's name		Co-driver's name											
	Driver's signature													
14 PRECEDING DAYS														
<b>Dates</b>	<b>1</b>	<b>2</b>	<b>3</b>	<b>4</b>	<b>5</b>	<b>6</b>	<b>7</b>	<b>8</b>	<b>9</b>	<b>10</b>	<b>11</b>	<b>12</b>	<b>13</b>	<b>14</b>
Total hours on-duty		10	10	10	10			10	10	10	10	10	10	10
Total hours off-duty	24	14	14	14	14	24	24	14	14	14	14	14	14	24

## Drivers who do not return to their home terminal

Drivers are required to fill out a daily log if they remain within the 160 km radius throughout the day and **do not return to their home terminal** to begin their 8 consecutive hours of off-duty time, even if the operator keeps a record.

### Example

A driver whose home terminal is in the city of Québec leaves Monday to go to work in Trois-Rivières until Friday (within the 160 km radius). When the driver arrives in Trois-Rivières, he goes to the local office, which will be his home terminal until Friday. He then makes deliveries within a 160 km radius of that local office. He goes there in the morning and returns there at the end of the work day. The operator keeps a record of the driver's hours.

### Logbook requirements

- ▶ **Monday and Friday:** The driver **must fill out a daily log**, because he does not return to the same home terminal at the end of the day.
- ▶ **Tuesday, Wednesday and Thursday:** The driver is **not required to fill out a daily log**, because he returns to the same home terminal, he remains within a 160 km radius, and the operator keeps a record.

# THE SUMMARY LOG: AN ESSENTIAL TOOL

Even though the driver is not required to use the log summary (log recap), it can be a useful tool. It enables the driver to calculate the number of hours of driving available at the beginning of the day, taking into account the hours of on-duty time accumulated in the preceding days. The number of preceding days on which the calculation is based depends on which cycle the driver is following and whether the number of hours of on-duty time has been reset to zero.

In the example given below, the driver initially follows cycle 1 (70 hours of on-duty time/7 days), then decides to switch to cycle 2 (120 hours of on-duty time/14 days).

Month	Total hours worked				
	Date	Hours worked	Cycle 1 last 6 days	Cycle 2 last 13 days	Hours available for the current day
April	25	12			
	26	12			
	27	0			
	28	12			
	29	12			
	30	7			
	May	1	12	55	
2		8	55		15
3		8	51		19
4		10	59		11
5		12	57		13
6		0	57		13
7		0			
8		11		0*	120
9		11		11	109
10		12		22	98
11		12		34	86
12		12		46	74
13		10		58	62
14		0**		68	52
15		12		68	52
16		12		80	40
17		12		92	28
18		12		104	16
19		4		116	4
20				120	0

\* On May 8, hours worked is reset to zero after the mandatory minimum of 36 off-duty hours to end cycle 1.

\*\* On May 14, cycle 2 was followed. 24 consecutive hours off-duty were taken to meet the second condition of cycle 2: a driver cannot drive after accumulating 70 hours of on-duty time without taking 24 consecutive hours of off-duty time.

## Meaning of the columns in the example

1. Column 1 indicates the day of the month, in the example, April and May.
2. Column 2 indicates the on-duty time (including hours of driving) for each day. The first 6 figures in column 2 indicate the on-duty time for the last six days of April.  

The remaining numbers in this column indicate the on-duty time for each day of May. (12 hours on May 1, 8 hours on May 2, etc., up to May 19, for which 4 hours of on-duty time are indicated.)
3. Column 3 is used when the driver is following **cycle 1**. It indicates the on-duty time for the **preceding 6 days**, unless the driver has begun a new cycle and less than 6 days have elapsed since the beginning of the new cycle. In the example, on May 1 the driver has accumulated a total of 55 hours of service in the preceding 6 days (from April 25 to April 30, inclusively).
4. Column 4 is used when the driver is following **cycle 2**. It indicates the on-duty time for the **preceding 13 days**, unless the driver has begun a new cycle and less than 13 days have elapsed since the beginning of the new cycle. In the example, the driver began **cycle 2** on May 8. On that date, the on-duty hours are reset to zero because the driver took at least 36 hours of off-duty time to **terminate cycle 1 and recommenced accumulating on-duty time**. At the beginning of the next day (May 9), the driver has accumulated 11 hours of on-duty time, the time worked on May 8.
5. Column 5 indicates the on-duty time available to the driver at the beginning of the current day to comply with the rules concerning the hours in a cycle.

In the example, the driver is initially following **cycle 1** and must therefore subtract the on-duty time accumulated in the last 6 days from 70 hours.

May 1: 70 hours – 55 hours (column 3) = 15 hours of on-duty time available in the cycle.

May 2: 70 hours – 51 hours (column 3) = 19 hours of on-duty time available in the cycle.

On May 6 and 7, the driver took at least 36 consecutive hours of off-duty time and can begin a new cycle 1 or switch to cycle 2 (in the example, the driver chooses to begin cycle 2). The accumulated on-duty time has been reset to zero: the driver recommences accumulating on-duty time from the first day of the new cycle.

May 8: 120 hours – 0 (column 4) = 120 hours of on-duty time available.

When following **cycle 2**, the driver cannot drive after accumulating 70 hours of on-duty time without having taken 24 consecutive hours of off-duty time. In this example, the driver took these off-duty hours on May 14.

# DOCUMENTS TO BE KEPT IN THE VEHICLE

Unless exempt, the driver must keep the following documents in the vehicle at all times:

- ▶ a copy of the daily logs for the 14 previous days;
- ▶ the daily log for the current day, completed up to the time of the last change of duty status;
- ▶ documents related to the trip, for example, gas receipts, bills of lading and delivery receipts.

# TRANSFER OF DOCUMENTS

The driver must submit the original copy of the completed daily log and supporting documents to the home terminal within 20 days.

A driver who is hired by more than one operator during the day must submit:

- ▶ the original copy of the daily log to the home terminal of the first operator for whom the driver worked and a copy of the same log to the home terminal of every other operator;
- ▶ the original copy of the supporting documents to the home terminal of the operator concerned.

All of these documents must be kept on file at the operator's establishment. The operator has 30 days from the date of receiving the documents to file them there.

# OUT-OF-SERVICE DECLARATION

A peace officer who issues an out-of-service declaration to a driver must notify the driver and the operator in writing of the reason the declaration was issued and the period it remains in effect. An out-of-service declaration may be issued for the following time periods and in the following circumstances:

## For the number of hours necessary to correct a failure of compliance

- ▶ The driver fails to comply with one of the requirements governing off-duty hours or with the conditions of the permit for exemption from hours of driving and off-duty time.

## For 10 hours

- ▶ The driver's ability to drive is impaired to the point where it is dangerous for him or her to drive.

OR

- ▶ The driver has driven more than 13 hours or has accumulated more than 14 hours of on-duty time in one day.

## For 72 hours

- ▶ The driver refuses or cannot produce, for a peace officer or an inspector, the daily logs, supporting documents or any other record the driver is required to have on hand.
- ▶ There is evidence showing that the driver has filled out more than one daily log, has entered inaccurate information in the log or has falsified information.



- ▶ The driver has defaced or mutilated a daily log or supporting document to the point where a peace officer cannot determine if the driver is in compliance with the requirements governing the hours of driving and off-duty time or with the conditions of the driver's permit for exemption from hours of driving and off-duty time.

## For more than 72 hours

- ▶ The out-of-service declaration applies until the driver corrects the daily log, where necessary, and submits it so that the peace officer can determine if the driver is in compliance with the requirements of the Regulation.

# A DRIVER'S RECORD

The operator and the individual who supplies the services of a driver must maintain and keep a file containing the following information and documents:

- ▶ a copy of the driver's licence;
- ▶ where the driver's licence has been suspended, modified or revoked, a statement signed by the driver giving notice of that fact;
- ▶ the date the driver was hired;
- ▶ a copy of the service contract entered into between the individual who supplies the services of a driver and the operator;
- ▶ the daily logs and the information that must be entered in the records;
- ▶ a copy of the permit for exemption from hours of driving and off-duty time;
- ▶ any supporting documents.

An operator who hires the services of a driver must maintain and conserve, for each driver, a copy of the service contract entered into between the individual who supplies the services of a driver and the operator, the daily logs, the information entered in records and any supporting documents.

Documents	Persons required to keep the document	Period the document must be kept*
A copy of the driver's licence	<ul style="list-style-type: none"> <li>▶ The operator, only for drivers employed by the operator</li> <li>▶ The individual who supplies the services of a driver</li> </ul>	At least 12 months after the date the driver is no longer working for the operator
The statement signed by the driver giving notice of the fact that his/her licence has been suspended, modified or revoked	<ul style="list-style-type: none"> <li>▶ The operator, only for drivers employed by the operator</li> <li>▶ The individual who supplies the services of a driver</li> </ul>	At least 12 months after the expiry date of the licence suspension or the date of the licence modification or revocation
The date the driver was hired	<ul style="list-style-type: none"> <li>▶ The operator, only for drivers employed by the operator</li> <li>▶ The individual who supplies the services of a driver</li> </ul>	At least 12 months after the date the driver ceased working for the operator
A copy of the service contract entered into between the individual who supplies the services of a driver and the operator	<ul style="list-style-type: none"> <li>▶ The operator, for drivers whose services are hired by the operator</li> <li>▶ The individual who supplies the services of a driver</li> </ul>	At least 12 months after the date the driver ceased working for the operator
The daily logs and the information that must be entered in the records	<ul style="list-style-type: none"> <li>▶ The operator, for all drivers who work for the operator</li> <li>▶ The individual who supplies the services of a driver</li> </ul>	At least 6 months after the date indicated in the daily log or record

A copy of the permit for exemption from hours of driving and off-duty time	▶ The operator, only for drivers employed by the operator	At least 6 months after the expiry date of the permit
Supporting documents (gas receipts, bills of lading, delivery receipts, etc.)	▶ The operator, for all drivers who work for the operator	At least 6 months after the date indicated on the supporting document

\* Other programs may require documents to be kept for a longer period (e.g. the International Registration Plan (IRP)).

## APPENDIX 1 – SLEEPER BERTH

A sleeper berth must meet the following requirements:

- ▶ It is designed for use as sleeping accommodations.
- ▶ It is located within the cab interior or immediately beside the cab and is firmly secured to the cab.
- ▶ It is not mounted on or inside a semi-trailer or trailer.
- ▶ If it is mounted in the cargo space, it is securely compartmentalized from the remainder of the cargo space.
- ▶ Where the vehicle is a bus:
  - ▶ It is located in the passenger compartment.
  - ▶ It is fitted with a bed at least 1.9 m long, 60 cm wide and 60 cm high.
  - ▶ It is separated from the passenger area by a solid material barrier that is fitted with a door that can be locked.
  - ▶ It ensures the privacy of the occupant.
  - ▶ It is equipped with a device that can be used to block out most of the light that enters the compartment.

- ▶ Where the vehicle is a heavy vehicle other than a bus, it is fitted with a rectangular bed that is at least:
  - ▶ 1.9 m long,
  - ▶ 60 cm wide,
  - ▶ 60 cm high.
- ▶ Its design allows an individual to enter and exit easily.
- ▶ There is a direct and easy way to move from the sleeper berth to the driver's seat or position.
- ▶ It is protected against leaks and overheating from the vehicle's exhaust system.
- ▶ It is equipped to provide adequate heating, cooling and ventilation.
- ▶ It is sealed adequately to protect from dust and rain.
- ▶ It contains a mattress at least 10 cm thick, as well as blankets and sheets or a sleeping bag.
- ▶ If the driver is travelling as part of a team, the bed must be equipped with a device that prevents the occupant from being ejected when the heavy vehicle brakes.

# APPENDIX 2 – LIST OF REQUIREMENTS, OFFENCES AND FINES

Drivers and operators must comply with the following legal obligations:	Sections of the HSC*	Sections and fines
<p>No driver may drive:</p> <ul style="list-style-type: none"> <li>▶ if doing so jeopardizes or is likely to jeopardize the safety or health of the public, the driver or the employees of the operator;</li> <li>▶ if the driver is the subject of an out-of-service declaration.</li> </ul>	519.8.1	519.44: \$350 to \$1,050 fine 519.34: \$700 to \$2,100 fine
A driver must comply with the standards governing cycles and hours of rest, driving and service.	519.9	519.44: \$350 to \$1,050 fine
<p>A driver must fill out only one daily log each day.</p> <p>A driver must fill out a daily log in accordance with required procedures and provide complete information about hours of rest and hours of service for the day, as well as any other required information.</p> <p>No driver may enter inaccurate information in a daily log or falsify, deface or mutilate a daily log or supporting documents.</p> <p>No driver may drive without having the required documents on hand.</p> <p>A driver must submit the daily log and supporting documents to the operator and any other individual who hires the driver.</p> <p>A driver must surrender these documents for inspection when so requested by a peace officer or inspector.</p>	519.10	519.44: \$350 to \$1,050 fine

<p>A driver must comply with any request made by a carrier enforcement officer during a roadside inspection or on-site inspection.</p> <p>No driver may in any way hinder peace officers in the performance of their duties, in particular by misleading them through concealment or false declarations, refusing to provide them with any information or document they are empowered to require or examine, or concealing or destroying any document or property relevant to an inspection.</p>	<p>519.70 519.71 and 638.1</p>	<p>519.77 and 638.1: \$700 to \$2,100 fine</p>
<p>A driver must maintain daily logs and records for a period of 6 months.</p>	<p>519.20</p>	<p>519.52: \$700 to \$2,100 fine</p>
<p>No operator may request, require or allow a driver to drive:</p> <ul style="list-style-type: none"> <li>▶ if the driver is the subject of an out-of-service declaration;</li> <li>▶ if the driver is in violation of the standards governing cycles, hours of rest, driving and service, and the daily log.</li> </ul>	<p>519.21.1</p>	<p>519.44: \$700 to \$2,100 fine</p>
<p>The operator must monitor the driver to ensure that he/she complies with all driver obligations.</p>	<p>519.21.2</p>	<p>519.44: \$700 to \$2,100 fine</p>
<p>The operator must require each driver to maintain a daily log recording all of the driver's hours of rest and hours of service for that day.</p>	<p>519.21.3</p>	<p>519.44: \$700 to \$2,100 fine</p>
<p>The operator must file and safeguard the daily logs and documents in a designated location and, when so requested by a peace officer or inspector and at the place indicated by the peace officer or inspector, surrender for inspection the daily logs, supporting documents and other documents required.</p>	<p>519.25</p>	<p>519.44: \$700 to \$2,100 fine</p>
<p>The operator must obtain the daily logs from the individual who supplies a driver's services.</p>	<p>519.26</p>	<p>519.44: \$700 to \$2,100 fine</p>

The operator or the driver must comply with any request made by a carrier enforcement officer during a roadside inspection or on-site inspection.

519.67.1  
and 519.70  
519.73

519.77: \$700 to  
\$2,100 fine

No operator or driver may hinder the work of peace officers or inspectors, mislead them through concealment or false declarations, refuse to provide them with information or documents that they are empowered to require or examine, or conceal or destroy any document or property relevant to an inspection.

\* HSC: *Highway Safety Code.*

## TRUE OR FALSE

	TRUE	FALSE
1. A work shift is the time between two periods of at least 8 consecutive hours of off-duty time.	<input type="checkbox"/>	<input type="checkbox"/>
2. A driver who is waiting at the home terminal for a trip to begin must consider this time as on-duty hours.	<input type="checkbox"/>	<input type="checkbox"/>
3. To be allowed to drive, a driver must have taken at least 24 consecutive hours of off-duty time during the 14 days preceding the current day.	<input type="checkbox"/>	<input type="checkbox"/>

Answers at the end of the guide.





# CIRCLE CHECK OF A VEHICLE

12

---

Mechanical factors are an issue in over 10% of accidents involving heavy vehicles and represent a loss of productivity for the goods and passenger transportation industry. However, most defects can be detected during an adequate sight and sound inspection of the vehicle before setting out.

For this reason, certain vehicles must undergo a summary inspection in order to maintain their authorization for road use. The driver or the person designated by the operator is responsible for carrying out this verification, which is called the *circle check*.

The purpose of the circle check is to ensure:

- ▶ that the vehicle's main components are in good working order;
- ▶ that the owner and the operator of the vehicle are informed of the necessary repairs;
- ▶ that a vehicle that has major defects is not used on the road.

An effective circle check may have direct repercussions on all users of the road network.

The three main goals of this chapters are to:

- ▶ **inform drivers** of vehicles subject to a circle check of their obligations regarding the inspection of the vehicle they are driving;
- ▶ **prepare drivers to carry out** a complete and effective **circle check**;
- ▶ **to make drivers aware of the preventive role they play** with respect to road safety when they carry out consistent and thorough inspections of the vehicle they are driving.

# WHAT IS THE CIRCLE CHECK?

The **circle check** is a **sight and sound inspection** of certain accessible components of a vehicle. Performing a circle check enables you to:

- ▶ detect defects at an early stage;
- ▶ quickly inform the operator and owner, who will take the necessary steps to ensure that the defects detected are repaired;
- ▶ avoid operating a vehicle when its condition might cause an accident or result in a breakdown.

An effective and thorough circle check increases the safety of drivers, passengers and all other road users.

## IS IT MANDATORY?

The circle check is **mandatory** for all vehicles subject to this inspection. Therefore, a driver cannot drive a vehicle and an operator cannot let a vehicle be driven if the circle check has not been carried out within the regulatory time frame. Note that a circle check report must be filled out for each circle check that is carried out.

# VEHICLES SUBJECT TO THE CIRCLE CHECK

The following vehicles are **required to undergo** a circle check:

- ▶ **road vehicles with a gross vehicle weight rating (GVWR) of 4,500 kg or more** (e.g. road tractor, straight-body truck, concrete mixer, tank truck, semi-trailer, van, pick-up truck, well drill, concrete pump, crane mounted on truck chassis, ambulance, fire department vehicle, etc.);
- ▶ **combinations of road vehicles<sup>4</sup> where at least one of the vehicles has a GVWR of 4,500 kg or more** (e.g. pick-up truck and trailer, tractor and semi-trailer, tractor and trailer);
- ▶ **buses, minibuses and tow trucks, regardless of their gross vehicle weight rating** (e.g. bus, minibus, minibus used for paratransit, school bus, city bus, tow truck);
- ▶ **road vehicles with a GVWR of less than 4,500 kg transporting dangerous substances** requiring the display of safety marks.

<sup>4</sup> In the case of a combination of road vehicles, if one vehicle has a GVWR of 4,500 kg or more, all the vehicles in the combination must be inspected.

# EXEMPT VEHICLES

The following vehicles are **exempt** from the circle check:

- ▶ **tool vehicles** (e.g. grader, wheel loader, back hoe);
- ▶ heavy vehicles used when required by an emergency service or in the event of a disaster;
- ▶ **farm tractors or farm machinery** (e.g. combine-harvester);
- ▶ **farm trailers** (e.g. a hay trailer owned by a farmer and used for agricultural purposes);
- ▶ **heavy vehicles used by a natural person** (an individual) for personal, non-commercial or non-professional purposes (e.g. truck used to move one's own belongings, motor home);
- ▶ **straight-body trucks with two or three axles**, used in any of the following circumstances:
  - ▷ to transport unprocessed farm, forest or fishery products, provided that the driver or operator of the truck is also the producer;
  - ▷ during the return trip, if the truck is empty or carries products used for the farm's, forest's or fishery's main production.

# WHO SHOULD PERFORM THE CIRCLE CHECK?

The **driver** must perform the circle check of the vehicle that he or she is driving. A **person designated by the operator** may also perform the check. In the latter case, the operator becomes accountable for the inspection.

The person designated by the operator may also be the vehicle's driver. In this case, the circle check report must indicate that the driver who performed the check did so as the person designated by the operator.

If the circle check is performed by a person designated by the operator, the driver may accept or refuse it:

- ▶ If he or she **accepts**: The driver makes sure that the circle check is valid (carried out within the previous 24 hours) and co-signs the report to acknowledge it. The driver is then not held accountable for the circle check, but he or she is still required to keep the report up to date and to report any defects detected during the trip.
- ▶ If he or she **refuses**: The driver must perform a new circle check and fill out a new report.

The driver behind the wheel must always make sure to update the circle check report and record any defects observed during the trip.

# VEHICLE USED BY MORE THAN ONE DRIVER

## Successive drivers (one driving after the other)

### Other vehicles subject to the circle check

When the vehicle is used successively by several drivers within a 24-hour period, each driver must perform a circle check before getting behind the wheel. However, if the operator has designated a person to perform the check, each subsequent driver is free to accept it, by co-signing it, or refuse it. A driver who refuses the check must perform a new circle check and fill out another report.

If one of the drivers regains control of a vehicle for which he or she has already carried out a circle check within the previous 24 hours, he or she is not required to fill out a new circle check report. However, the initial report must:

- ▶ be on board the vehicle;
- ▶ accurately reflect the condition of the vehicle at the time the driver regains control of it.

If another driver has operated the vehicle in the meantime, it is preferable to perform a new circle check or review the report made by the other driver and update one's own report if defects were detected.

### For buses, minibuses, tow trucks and emergency vehicles (other than fire department vehicles)

In these special cases, even if the circle check is performed by a driver who is not a person designated by the operator, successive drivers can accept the circle check report and co-sign it. In such a case, the driver co-signing the report assumes responsibility for it and must then keep it updated. If the driver refuses it, he or she must perform a new circle check.

There are special conditions that apply to the validity periods of circle check reports for these types of vehicles. They are explained in the following sections.

### **Team drivers (alternating driving)**

When the vehicle is used by a team, the following method is recommended if the operator has not designated one of the drivers to carry out the circle check:

- ▶ the first driver carries out the circle check and fills out the circle check report;
- ▶ the relief driver, when preparing to take the wheel, carries out another circle check and fills out a new report.

Both these reports remain valid for a period of 24 hours.

If the operator designates one of the two drivers to carry out the circle check, the other driver can, when preparing to take the wheel, review the report and:

- ▶ co-sign the report, if he or she accepts it;
- ▶ carry out a new circle check and fill out a new report, if he or she refuses it.

### **Motor coaches: a special case**

In the case of a motor coach being driven by a team, the relief driver, when preparing to take the wheel, may co-sign the first driver's circle check report if he or she accepts it, even if the preceding driver was not designated by the operator. In such a case, the driver is accountable for the circle check carried out by the preceding driver. In addition, he or she... must keep the circle check report up to date and report any defects detected during the trip.



## WHO SHOULD REPORT DEFECTS DETECTED DURING THE TRIP?

### Drivers:

- ▶ are in the **best position to detect symptoms** of unusual behaviour in their vehicle;
- ▶ **are always responsible for reporting the defects noted during a trip**, even if the circle check was performed by a person designated by the operator. Drivers must therefore be very vigilant;
- ▶ must always **be able to carry out an inspection** of their vehicle and **recognize the defects** normally detected during a circle check.

## WHEN SHOULD THE CIRCLE CHECK BE PERFORMED?

Generally, drivers must make sure that an inspection was performed within the 24 hours prior to driving a vehicle. Otherwise, a new inspection must be carried out. Furthermore, if the circle check was not carried out by a person designated by the operator, the driver must perform a new inspection even if fewer than 24 hours have elapsed.

Drivers must also plan their activities in order to be able to perform a new circle check **before 24 hours have elapsed**, except in the case of certain vehicles to which different time limits apply.

## Special cases

Although a circle check must generally be performed before 24 hours have elapsed, some vehicles may be subject to particular rules:

- A. heavy vehicles subject to road tests following repairs;
- B. fire department vehicles;
- C. buses, minibuses and emergency vehicles (except fire department vehicles);
- D. Buses or minibuses used for urban transit and operated by a public transit authority.

### A. Heavy vehicles subject to road tests following repairs

A circle check **is not required** if all of the following conditions are met:

- ▶ the road test is done within a **15 km radius** from the place where the vehicle was repaired;
- ▶ the vehicle **is not transporting any goods** (other than permanent equipment);
- ▶ the vehicle **is not transporting any passengers** (other than those involved in the road test);
- ▶ the report of the most recent circle check performed on the vehicle or the work order is on board the vehicle.

### B. Fire department vehicles

A circle check must have been performed during the 24 hours preceding an outing or upon the vehicle's return to the station. When a vehicle remains in the station, an inspection must be conducted **at least once every 7 days**.

### C. Buses, minibuses and emergency vehicles (except fire department vehicles)

For those vehicles only, and if they remain parked after the circle check has been completed, Saturdays, Sundays and statutory holidays do not count in the 24-hour validity period of the circle check.

### D. Buses or minibuses used for urban transit and operated by a public transit authority

The circle check remains valid for either of the following periods, whichever elapses first:

- ▶ 48 hours, on the condition that the **vehicle remains parked and indoors during this period**;<sup>5</sup>
- ▶ 24 hours, starting from **when it is put into operation**.

This special case applies only if the following conditions are respected:

- ▶ the circle check is carried out by a person designated by the operator;
- ▶ the vehicle is a bus or a minibus used for urban transit and operated by a public transit authority.

<sup>5</sup> Saturdays, Sundays and statutory holidays do not count in the 48-hour period that elapses as of the moment the circle check was carried out when the vehicle remains parked and indoors during this period. This rule only applies if the circle checks are carried out by a person designated by the operator for this purpose for buses or minibuses used for urban transit and operated by a public transit authority.

# RESPONSIBILITY FOR THE CONDITION OF THE VEHICLE

All persons involved in the operation of a vehicle have obligations regarding its general condition:

▶ **Owners**

Must maintain their vehicles in good mechanical condition and have the reported defects repaired.

▶ **Operators**

Must, among other things, make sure that the driver or the designated person conducts the circle check in compliance with regulatory requirements.

▶ **Drivers**

Must perform the circle check in compliance with regulatory requirements, except if they accept the inspection performed by the person designated by the operator (or the inspection performed by the preceding driver, in certain specific cases). They must also report any defects detected during a trip.

# MECHANICAL DEFECTS

# 12

All persons involved have a duty to intervene when a vehicle's mechanical condition presents anomalies. Anomalies that represent an immediate or short-term risk to road safety are considered major or minor defects.

## Minor defect

A minor defect does **not pose an immediate risk** to the safety of the driver and the other road users, but could deteriorate quickly in certain cases. A vehicle with a minor defect **cannot be operated if repairs are not performed within 48 hours**.



## Major defect

A major defect poses an **immediate risk to safety**. Accordingly, it is **prohibited to operate or to allow operation** of a vehicle with a major defect.



## Lists of defects

The list of defects is a checklist that enumerates the components to inspect and the defects that can be detected on a vehicle. It is useful for quickly determining whether a defect detected is minor or major.

There are three different lists of defects. Each is adapted to the features of the type of vehicle inspected:

▶ **List 1 – Heavy vehicles**

For all heavy vehicles, except those covered by lists 2 and 3.

▶ **List 2 – Buses**

For buses (excluding motor coaches), minibuses and trailers hauled by a bus, a minibus or a motor coach.

▶ **List 3 – Motor coaches**

For motor coaches.<sup>6</sup>

The three lists of mechanical defects can be found in the appendices.

<sup>6</sup> When the motor coach is not subject to a preventative maintenance program (PMP) recognized by the SAAQ, the driver must make sure to have the report of the inspection specific to motor coaches and List 3 on board the vehicle. The owner is required to fill out this report every 12,000 km or every 30 days, whichever comes first, and place the report in every motor coach under his or her responsibility.

# OBLIGATION REGARDING THE LIST OF DEFECTS

# 12

The contents of the list of defects is prescribed and its presence on board the vehicle is mandatory.

## Operators:

- ▶ must place, in each heavy vehicle under his or her responsibility, the applicable list of defects in the format prescribed under the *Regulation respecting safety standards for road vehicles* (the text, order of presentation and numbering cannot be modified). However, elements may be added to the “Specific inspections required by the operator” section;
- ▶ must make sure the driver keeps the list on board the vehicle.

## Drivers:

- ▶ must ensure that the list of defects that applies to the vehicle is and remains on board the vehicle under their responsibility. They must also hand over the list to any peace officer who so requests.

# COMPONENTS TO INSPECT

The lists of defects list the components that must be inspected during the circle check. List 1 is used to inspect heavy vehicles and has 19 components. Lists 2 and 3, used for buses and motor coaches, have a 20th section that concerns components that apply to vehicles used to carry passengers.

The circle check concerns the following components:

- |                              |                                |
|------------------------------|--------------------------------|
| 1. Coupling devices          | 11. Glass and mirrors          |
| 2. Frame and cargo body      | 12. Wheels, hubs and fasteners |
| 3. Heater/defroster          | 13. Seat                       |
| 4. Driver controls           | 14. Suspension                 |
| 5. Steering                  | 15. Fuel system                |
| 6. Windshield wiper/washer   | 16. Exhaust system             |
| 7. Emergency material        | 17. Electric brake system      |
| 8. Headlights and lights     | 18. Hydraulic brake system     |
| 9. Tires                     | 19. Pneumatic brake system     |
| 10. Doors and other openings | 20. Passenger transport        |

Note that all vehicles are not necessarily equipped with all the components indicated in the list of defects (hydraulic brakes or coupling mechanism, for example). In this case, these parts do not have to be verified. Furthermore, some parts may be missing from a vehicle although they should be present. Their absence constitutes a defect that must be reported.

Moreover, **the minor defects detected and covered by the list must be entered in the circle check report and reported** to the operator before the next circle check or within 24 hours, whichever comes first. You should also report any other anomaly, even if it is not covered by the list of defects.



# THE INSPECTION REPORT

# 12

The circle check report differs from the list of defects. The inspection report **must be filled out during each circle check**. It allows the driver or the person designated by the operator to inform the operator or owner of the vehicle of the **results of the inspection** and, if applicable, the defects detected. This report also records the time at which the inspection was performed and its validity period.

## Is it mandatory?

The person who performs the circle check must fill out the report and make sure to record the defects that were detected. The driver must also add any defect that is noted during the trip.

The circle check report is also used to report certain observations or anomalies that are not listed on the list of defects. This is why the report must be kept meticulously up-to-date.

It is also mandatory to keep the completed and valid circle check report and the list of defects on board the vehicle. If the report is not on board, the driver must obtain it or perform the inspection again. Furthermore, for each circle check, a single report must be filled out. It is suggested that it be kept with the list of defects.

## What should it include?

Regulations do not require that the circle check report be presented in a specific format. However, it must include the following information:

- ▶ the vehicle's licence plate number or the unit number found on the registration certificate;
- ▶ the operator's name;
- ▶ the date and time at which the circle check was performed;
- ▶ the municipality or location on the road where the circle check was performed;
- ▶ defects noted during the circle check or the trip;
- ▶ if no defect was noted, this must be indicated as well;
- ▶ the name of the person who performed the circle check (printed legibly);
- ▶ a declaration, signed by the driver or the person designated to perform the inspection, attesting that the vehicle has been inspected according to applicable requirements;
- ▶ if the driver did not perform the inspection, his or her signature to attest that he or she has reviewed the inspection and accepted it;
- ▶ the kilometrage indicated by the odometer if the vehicle is equipped with one.

## Example of an inspection report

Here is an example of a circle check report that includes the mandatory elements:

<b>Defects</b>	No defects were noted during the circle check: <input type="checkbox"/>	
<b>Person Who Performed the Inspection</b>		
Last name: _____	First name: _____	(please print)
Person designated by the operator to perform the circle check: Yes <input type="checkbox"/> No <input type="checkbox"/>		
I personally inspected the vehicle and confirm that it was inspected according to the applicable requirements.		
Signature: _____		
<b>Driver's Declaration (where the driver did not perform the circle check)</b>		
<b>Buses, Minibuses, Tow Trucks or Emergency Vehicles</b>	<b>All Other Heavy Vehicles</b>	
The driver can decide to review the existing report that was completed by the person designated by the operator or by the previous driver, and co-sign below.	The driver can decide to review the existing report that was completed by the person designated by the operator and co-sign below.	
<b>The driver can always decide to perform a complete inspection of the vehicle himself/herself and fill out a new circle check report.</b>		
I have reviewed the circle check report.		
Driver's signature: _____		
Driver's signature: _____		
Driver's signature: _____		

### CIRCLE CHECK REPORT

#### Operator

Name: \_\_\_\_\_

#### Vehicle

Licence plate number:\* \_\_\_\_\_

Kilometrage: \_\_\_\_\_

#### Circle Check

Date: \_\_\_\_\_

Time: \_\_\_\_\_

Municipality or location: \_\_\_\_\_

\*or the unit number, if it appears on the registration certificate

## When should a defect be reported?

### Minor defect

A minor defect must be recorded in the circle check report and be notified to the operator at the first occurrence of the following two possibilities:

- ▶ **before the next circle check;**
- ▶ **in the 24 hours following the writing of the report.**

It is recommended to report the defect as soon as possible to avoid delays in repairs. If the operator is not the owner of the vehicle, he or she must inform the owner to ensure follow-up. Quick intervention may allow the defect to be repaired even before the vehicle sets out on the road, thereby ensuring it is operated safely.

### Major defect

A major defect must be **immediately recorded in the circle check report** and be **reported without delay** to the operator. A major defect constitutes a **prohibition from operation**, meaning that the vehicle with a major defect may not be driven or put into operation.

## When should the inspection report be handed in?

The driver must submit the **original copy of the circle check report** to the operator within **20 days of its writing**. This obligation applies even when a copy has already been submitted to the operator (to report a defect, for example).

## Circle Check Report in Electronic Format

Although regulatory provisions clearly specify the elements that must be included in a circle check report, nothing specifies the format in which it must be produced. The use of an electronic document is thus permitted, but it must meet the requirements set forth in the Act to establish a legal framework for information technology.

To know more, refer to Appendix 6 of the *Circle Check Guide*.

## Driving in Canada and the United States

Rules in effect in Québec with respect to circle checks are based on National Safety Code Standard 13. Québec carriers who operate in another Canadian province or territory therefore benefit from harmonized regulations.

Despite regulatory reciprocity in many North American jurisdictions, there may be differences with respect to minor and major defects from one place to another. This is why drivers who operate outside Québec must consult the operator regarding the specific regulations in the jurisdiction where they must operate, as the owner is responsible for knowing these regulations.

Drivers must always comply with the regulations that apply in the jurisdiction in which they are travelling. Of course, ignorance of the regulations does not relieve drivers of this obligation.

# DRIVERS AND THE CIRCLE CHECK

Subjecting a vehicle to regular preventive maintenance is the best way to anticipate the degradation of mechanical elements and limit hazards due to their bad condition. Although proper vehicle maintenance is mainly the responsibility of the owner and the operator and not a requirement of the circle check, good drivers should be careful to ask about the date of the vehicle's most recent preventive maintenance.

Regular preventive maintenance does not prevent a vehicle from experiencing a sudden breakdown, whatever its cause. Drivers should remember that even if the operator designates another person to perform the circle check, they remain responsible for reporting defects noted during a trip and for conducting a new inspection if needed.

This is why drivers must have at least some knowledge of the components of the vehicle they are driving, be careful to give particular attention to their condition and be able to detect certain defects.

# TABLE OF COMPONENTS TO INSPECT AND DEFECTS TO BE DETECTED

As part of the circle check, drivers must inspect the components listed in the table below. Although the regulatory requirements only call for a sight and sound check, it is sometimes useful to physically touch various components to ensure their solidity, for example.

This table is meant to help you determine whether defects noted with regards to the components inspected are minor or major. The column on the left lists the components (parts) covered and the inspections to perform during the mandatory circle check. The centre column specifies where and how to check and suggests ways to make the inspections more effective. The column on the right lists the minor and major defects that drivers must be able to detect. Pay attention to the complementary notes!

In case of doubt regarding the nature of a defect, do not hesitate to consult a mechanic authorized to perform mechanical inspections or the operator. This is a matter of your own safety and the safety of others. Any defect detected during the circle check must be entered in the circle check report.

## Be vigilant and exercise caution!



For more information on the circle check and the various defects, consult the *Circle Check Guide*, available on the website of the Société de l'assurance automobile du Québec.

The following icons are used in the table below:



Minor defects



Major defects



Offences under the *Highway Safety Code* that are not considered a defect within the meaning of the *Regulation respecting safety standards for road vehicles*.

For purposes of inspecting the air brakes and air suspension systems, here are the units of measurement for conversion, which may be useful for different models of vehicles:

- ▶ 1kPa = 0.14503 psi
- ▶ 1psi (lb/in<sup>2</sup>) = 6.895 kPa
- ▶ 100 kPa = 1 bar
- ▶ 1kcm<sup>2</sup> = 14.22 psi (lb/in<sup>2</sup>)

In the International System of Units (SI), pressure is expressed in kilopascals (kPa). Pressure in kilopascals is calculated by multiplying pounds per square inch by 6.895. A pressure conversion table is provided in the appendices.



## 1 - COUPLING DEVICES

Parts covered and purpose of the inspection

Where and how to check

Categories of observable defects

### Fifth wheel (fixed or sliding) coupling device

Device found on semi-trailer tractors, dollies and some pickup trucks

**Important:** Non-load-bearing sections (in red) are not covered by the circle check.

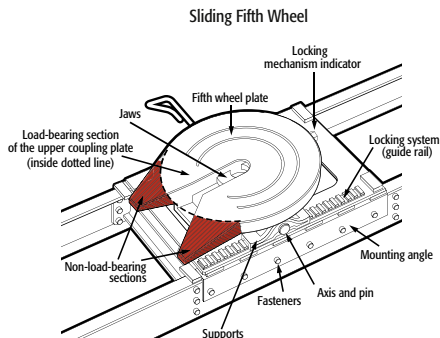

Covers the fixed or sliding fifth wheel

#### Parts covered

- ▶ Fifth wheel fasteners (nuts and bolts)

Check the mounting angles to make sure all parts that fasten the fifth wheel to the vehicle frame are present and securely attached.



#### On both sides of the road vehicle, facing the fifth wheel

- ▶ Inspect the mounting angle and check for the presence and condition of the nuts and bolts that fasten the fifth wheel to the vehicle frame.

**Important:** The percentages covered by the defects are for each of the fifth wheel mounting angles.

**Note:** A fifth wheel fastener that is missing, cracked, misshapen or not securely mounted poses a danger to hitching solidity.

**Be vigilant!**



**1.B**  
When the vehicle is hitched, there is some movement between a fifth wheel fastener (mounting angle) and the vehicle chassis frame.



**1.C**  
When the vehicle is hitched, more than 20% of the parts fastening the fifth wheel to the vehicle frame are missing, broken or loose on an anchorage.







**1.1**  
When the vehicle is hitched, 20% or less of the parts fastening the fifth wheel to the tractor frame are missing, broken or loose on an anchorage.



**1.1**  
When the vehicle is unhitched, one or more parts fastening the fifth wheel is/are missing, broken or loose.

## 1 - COUPLING DEVICES

Parts covered and purpose of the inspection	Where and how to check	Categories of observable defects
<p>Covers the sliding fifth wheel</p> <p><b>Parts covered</b></p> <ul style="list-style-type: none"> <li>▶ The sliding fifth wheel locking pins</li> </ul> <p>Check for the presence and condition of the sliding fifth wheel locking pins.</p> 	<p><b>On both sides of the road vehicle, facing the sliding fifth wheel</b></p> <ul style="list-style-type: none"> <li>▶ Check for the presence of the locking pins.</li> <li>▶ Make sure the pins* are in locked position.</li> </ul> <p>*The fifth wheel is generally locked by two pins (one on each side), and sometimes more. It is important to check all pins.</p> <p><b>Important:</b> The percentage covered by the defect concerns the sum of all pins.</p>	<p> <b>1.D</b></p> <p><b>When the vehicle is hitched, 25% or more of the locking pins of a sliding fifth wheel are missing or inoperative.</b></p>
<p>Covers the fixed or sliding fifth wheel</p> <p><b>Parts covered</b></p> <ul style="list-style-type: none"> <li>▶ Components of the fifth wheel (lower coupling plate, mounting angles, jaws, support, etc.)</li> </ul> <p>Check the condition of the of the fifth wheel components.</p>	<p><b>On both sides of the road vehicle, facing the fifth wheel</b></p> <ul style="list-style-type: none"> <li>▶ Inspect the visible parts of the fifth wheel components.</li> </ul> 	<p> <b>1.F</b></p> <p><b>When the vehicle is hitched, a component of the fifth wheel is cracked, misshapen or deteriorated* to the point that there is a risk of breakage or separation from the combination of vehicles.</b></p> <p>*For example, broken or worn.</p>

## 1 - COUPLING DEVICES

## Parts covered and purpose of the inspection

Covers the semi-trailer's coupling device

## Parts covered

- ▶ The upper coupling plate and kingpin

Check the condition of the upper coupling plate and kingpin.

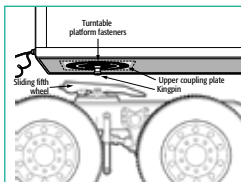

## Where and how to check

## On both sides of the semi-trailer, facing the fifth wheel

- ▶ Inspect the visible parts of the upper coupling plate and kingpin underneath the semi-trailer.



**Note:** It is difficult to see a deformation of the plate or kingpin when the vehicles are hitched. Moreover, if the vehicle is to be unhitched during the trip, you can use this opportunity to check these points.

## Categories of observable defects



## 1.A

The coupling plate or kingpin is so misshapen that it adversely affects hitching, or is cracked or improperly secured.



## 1.F

**When the vehicle is hitched**, the coupling plate or kingpin is deteriorated\* to the point that there is a risk of breakage or separation from the combination of vehicles.

\*For example, broken or worn.

## 1 - COUPLING DEVICES

## Parts covered and purpose of the inspection

Covers the fixed or sliding fifth wheel

## Parts covered

- ▶ The fifth wheel jaws and the jaws locking mechanism indicator

Check the fifth wheel jaws and the position of its locking mechanism indicator.

## Where and how to check

## Behind the vehicle, facing the fifth wheel

- ▶ Inspect the fifth wheel jaws to make sure they are properly closed.





**Note:** It is difficult to see whether the jaws are closed without sliding under the semi-trailer. If you must do so, please proceed safely. Notify someone around you beforehand and take all necessary measures to prevent any movement of the vehicle during this inspection. Make sure the engine is turned off and that the vehicle is stationary.

## Categories of observable defects



- 1.E**  
When the vehicle is hitched, the jaws are not completely closed behind the kingpin.

1 - COUPLING DEVICES		
Parts covered and purpose of the inspection	Where and how to check	Categories of observable defects
	<p><b>On the side of the road vehicle, facing the fifth wheel</b></p> <p>► Inspect the locking mechanism indicator (bolt) located in front of the fifth wheel. If there is no indicator, check the position of the locking handle(s).</p>  <p><b>Note:</b> The fifth wheel may be equipped with two locking handles (usually on the same side). It is important to check whether they are all completely pushed in to make sure the device is completely locked.</p>	<p> <b>1.F</b> When the vehicle is hitched, the jaw locking mechanism is not engaged.</p>

## 1 - COUPLING DEVICES

Parts covered and purpose of the inspection

Where and how to check

Categories of observable defects

All other coupling devices other than a fifth wheel (e.g. hook and ring)

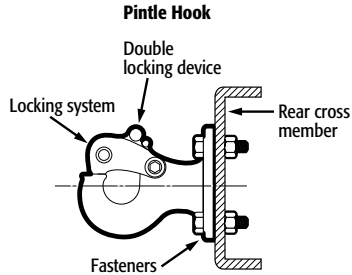
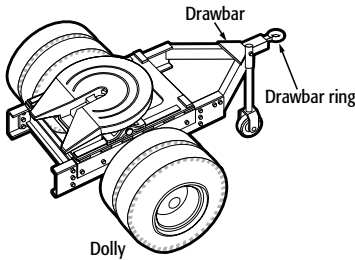

**Important:** Trailers equipped with a drawbar generally include a ring to which a hook can be connected.

Covers all coupling devices other than a fifth wheel

**Parts covered**

► Coupling device fasteners (e.g. nuts and bolts)

Check for the presence and solidity of the parts that attach the coupling device to the vehicle.



**On both sides of the combination of vehicles, between the tractor vehicle and the trailer**

- Inspect the parts that attach the coupling device to the tractor vehicle (e.g. the nuts and bolts that attach the hook to the vehicle pulling the trailer).
- Inspect the parts that attach the coupling device on the vehicle being pulled (e.g. the nuts and bolts that attach the ring to the drawbar).



**1.C**  
When the vehicles are hitched, more than 20% of the fasteners that attach the coupling device to the vehicle are missing, broken or loose.



**1.1**  
When the vehicles are hitched, 20% or less of the fasteners that attach the coupling device to the vehicle are missing, broken or loose.



**1.1**  
When the vehicles are unhitched, one or more of the fasteners are missing, broken or loose.

## 1 - COUPLING DEVICES

## Parts covered and purpose of the inspection

Covers all coupling devices other than a fifth wheel

**Parts covered**

- Components of the coupling device (drawbar ring, pintle hook, etc.)

Check the condition of the components of the coupling device.

**Important:** A converter dolly uses two types of coupling devices: a fifth wheel device (1) and a pintle hook/drawbar ring device (2). Both must be checked.



## Where and how to check

**On both sides of the combination of vehicles, facing the coupling device**

- Inspect the coupling device on the tractor vehicle (pintle hook, pintle hook locking mechanism, etc.) and the vehicle being pulled (ring, drawbar, etc.).



**Note:** It is important that the pintle hook locking mechanism be in proper working order to avoid the risk of the combination of vehicles separating.



## Categories of observable defects



1.F  
When the vehicles are hitched, a component of the coupling device is missing, improperly secured, cracked, misshapen or deteriorated\* to the point that there is a risk of breakage or separation of the combination of vehicles.

\*For example, broken or worn.

## 1 - COUPLING DEVICES

Parts covered and purpose of the inspection	Where and how to check	Categories of observable defects
<p>Covers all coupling devices other than a fifth wheel</p> <p><b>Parts covered</b></p> <ul style="list-style-type: none"> <li>▶ Safety fasteners and their coupling components (steel cables, chains, hooks, rings to which the chains must be attached, etc.)</li> </ul> <p>Check for the presence and condition of the safety fasteners or coupling components.</p> <p><b>Important:</b> Safety fasteners and their coupling components are mandatory when the trailer is not equipped with emergency brakes that enable the trailer to be stopped in the event of separation.</p>	<p><b>Between the tractor vehicle and the trailer</b></p> <ul style="list-style-type: none"> <li>▶ Inspect the safety fasteners and coupling components.</li> </ul> 	<p> <b>1.2</b> A safety fastener or a coupling component is missing, deteriorated* or improperly attached.</p> <p>*For example, broken or worn.</p>



## 2 - FRAME AND CARGO BODY

Parts covered and purpose of the inspection

Where and how to check

Categories of observable defects

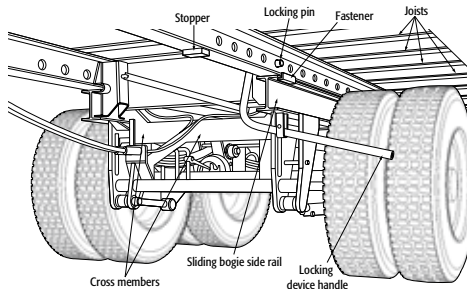

### Parts covered

► Side rails and cross members  
Check the solidity and condition of the side rails and cross members (also known as "joists").

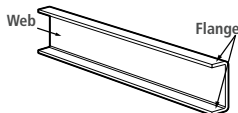
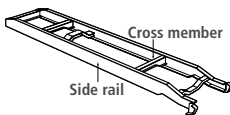
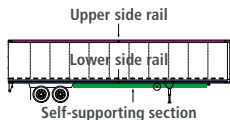

### Around the vehicle

► Inspect the visible sections of the side rails and cross members (cracks, breaks, etc.)

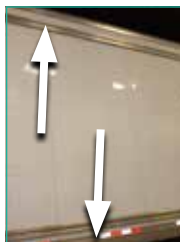

**Important:** A scratch is not a crack. If you are unsure how serious a crack is, consult the person in charge of mechanical inspection.



**2.A**  
A side rail is in danger of breaking.



**2.B**  
A side rail or cross member sags and makes a moving part\* come into contact with the body.

\*For example, tires, wheels, steering or suspension components.



**2.1**  
The side rail web is cracked.





**2.1**  
The side rail flange is cracked.



**2.1**  
A cross member is cracked or broken.



## 2 - FRAME AND CARGO BODY



Parts covered and purpose of the inspection	Where and how to check	Categories of observable defects
<p><b>Parts covered</b></p> <ul style="list-style-type: none"> <li>▶ The locking pins that secure a sliding bogie under the semi-trailer</li> </ul> <p>Check for the presence and the position of locking pins of the sliding bogie under the semi-trailer.</p>	<p><b>Outside the vehicle, on both sides of the semi-trailer's rear wheels</b></p> <ul style="list-style-type: none"> <li>▶ Inspect the sliding bogie and make sure the locking pins are present and in the locked position.</li> </ul> 	<p> <b>2.C</b> More than 25% of the locking pins are missing or not in the locked position.</p>
<p><b>Parts covered</b></p> <ul style="list-style-type: none"> <li>▶ Fixed components of the body (hood, body panels, fenders, bumpers, etc.)</li> </ul> <p>Check whether the fixed components of the body are present and securely mounted.</p>	<p><b>Around the vehicle</b></p> <ul style="list-style-type: none"> <li>▶ Inspect the fixed components of the body such as the body panels, fenders and bumpers.</li> </ul>	<p> <b>2.2</b> A fixed component of the body is missing or improperly mounted.</p>

## 2 - FRAME AND CARGO BODY



Parts covered and purpose of the inspection	Where and how to check	Categories of observable defects
<b>Additional check for buses (including motor coaches).</b>		
<p><b>Parts covered</b></p> <ul style="list-style-type: none"> <li>▶ The outside doors of the luggage compartments and auxiliary compartments</li> </ul> <p>Check for the presence and solidity of the outside doors of the luggage compartments and auxiliary compartments.</p>	<p><b>Around the vehicle</b></p> <ul style="list-style-type: none"> <li>▶ Inspect the doors of the luggage compartments and auxiliary compartments (such as the battery compartment).</li> </ul> 	<p><b>2.3</b></p> <p><b>An outside door of a luggage compartment or auxiliary compartment is inadequate* or improperly mounted to the road vehicle.</b></p> <p>*An outside door of a luggage compartment or auxiliary compartment is inadequate when it does not close or is not in proper working order.</p>



## 3 - HEATER/DEFROSTER

Parts covered and purpose of the inspection	Where and how to check	Categories of observable defects
<p><b>Part covered</b></p> <p>► The windshield blower</p> <p>Check the working order of the windshield blower.</p> <p><b>Important:</b> Only the components provided by the manufacturer are covered by this inspection. Auxiliary systems are not concerned.</p>	<p><b>In the cab</b></p> <ol style="list-style-type: none"> <li>1. Switch on the blower and direct the air flow toward the windshield.</li> <li>2. Check whether the air blows onto the windshield.</li> </ol>  <p><b>Note:</b> The defect does not cover the temperature of the air flow. However, in winter, it is important to make sure the air temperature is warm enough to defrost the windshield so as to ensure the best visibility for safe driving.</p> <p>Furthermore, under section 265 of the <i>Highway Safety Code</i>, the windshield must be free of any material* that may reduce visibility for the driver.</p> <p>*In this context, fog is considered to be a material.</p>	<p><b>3.1</b></p> <p> The windshield blower is not working.</p>





4 - DRIVER CONTROLS		
Parts covered and purpose of the inspection	Where and how to check	Categories of observable defects
<p><b>Part covered</b></p> <p>► The accelerator</p> <p>Check the working order of the accelerator.</p> 	<p><b>In the driver's compartment</b></p> <ol style="list-style-type: none"> <li>1. When the vehicle is stationary (parking brake engaged), the engine is running and the transmission is in neutral, press on the accelerator (but not to maximum rpm).</li> <li>2. Release the accelerator.</li> <li>3. Make sure the engine returns to idle by watching the tachometer.*</li> </ol> <p>*In the absence of a tachometer, listen to the sound of the engine.</p>	<p> <b>4.A</b> The engine does not return to idle after the accelerator is released.</p> <p> <b>4.1</b> The engine does not accelerate or does not return to idle in a normal manner when the accelerator is released.</p>

## 4 - DRIVER CONTROLS

Parts covered and purpose of the inspection	Where and how to check	Categories of observable defects
<p>Covers vehicles with a manual (standard) transmission</p> <p><b>Part covered</b></p> <p>► The clutch control</p> <p>Check the working order of the clutch.</p> 	<p><b>In the driver's compartment</b></p> <ol style="list-style-type: none"> <li>1. Make sure the parking brake is engaged.</li> <li>2. Make sure the transmission is in neutral.</li> <li>3. Press on the clutch pedal and start the engine.</li> <li>4. Put the gearshift lever into a gear.</li> <li>5. Release the parking brake.</li> <li>6. Let the vehicle move forward by delicately and completely releasing the clutch pedal.*</li> <li>7. Press the clutch pedal once again and apply the brakes to stop the vehicle.</li> <li>8. Shift the transmission into neutral and apply the parking brake.</li> </ol> <p>*Note that any gear slip that cannot be compensated for by an adjustment represents wear that can hamper its proper working order.</p>	<p><b>4.1</b></p> <p> The clutch mechanism is not in proper working order.</p>





4 - DRIVER CONTROLS		
Parts covered and purpose of the inspection	Where and how to check	Categories of observable defects
<p><b>Part covered</b></p> <ul style="list-style-type: none"> <li>▶ The horn</li> </ul> <p>Check the working order of the horn.</p> <p><b>Note:</b> The mandatory inspection only covers the working order of the horn.</p> <p>The circle check does not concern any defects concerning the physical aspect or mounting of the horns (e.g. trumpets mounted on some vehicles). However, any anomaly that would cast doubt about the solidity of the parts should be reported for verification.</p>	<p><b>In the driver's compartment</b></p> <ul style="list-style-type: none"> <li>▶ Activate the horn.</li> </ul>  <p><b>Note:</b> If the vehicle is equipped with two horns, you are required to check at least one of them.</p>	<p> <b>4.2</b> The horn is not working.</p>

## 5 - STEERING



Parts covered and purpose of the inspection	Where and how to check	Categories of observable defects
<p><b>Part covered</b></p> <ul style="list-style-type: none"> <li>▶ The power steering pump reservoir</li> </ul> <p>Check the power steering fluid level.</p> 	<p><b>In the engine compartment</b></p> <ul style="list-style-type: none"> <li>▶ Check the fluid level in the power steering pump reservoir.*</li> </ul> <p><b>Note:</b> The power steering fluid level is checked by viewing the gauge or marks on the reservoir.</p> <p>*If you have to open the power steering reservoir because you cannot check the fluid level from the exterior, certain precautions are recommended:</p> <ol style="list-style-type: none"> <li>1. Clean all around the opening of the reservoir to avoid introducing any contaminants into the fluid;</li> <li>2. Put the seal back into its proper position, if it was removed.</li> <li>3. Close the cover tightly.</li> </ol>	<p><b>5.2</b></p> <p> The fluid level in the reservoir is lower than the minimum level or higher than the maximum level prescribed by the manufacturer.</p>
<p><b>Part covered</b></p> <ul style="list-style-type: none"> <li>▶ The power steering pump belt</li> </ul> <p>Check the condition of the power steering belt.</p> <p>Important: Most heavy vehicles are no longer equipped with a belt-driven power steering pump.</p>	<p><b>In the engine compartment</b></p> <ul style="list-style-type: none"> <li>▶ Inspect the power steering pump belt if it is accessible.</li> </ul> 	<p><b>5.3</b></p> <p> The power steering pump belt is cut.</p> <p><b>Note:</b> If the belt is cut to the point that the working order of the power steering is hampered, the defect becomes a major defect (see the following point - power steering).</p>



## 5 - STEERING

Parts covered and purpose of the inspection	Where and how to check	Categories of observable defects
<p><b>Part covered</b></p> <ul style="list-style-type: none"> <li>▶ The power steering</li> </ul> <p>Check the working order of the power steering.</p>	<p><b>In the driver's compartment, while the engine is running</b></p> <ul style="list-style-type: none"> <li>▶ Check the power steering by turning the steering wheel from side to side so as to move the wheels.</li> </ul>  <p>Note: For certain types of vehicles, it may be necessary for the vehicle to move forward slightly to check the power steering.</p>	<p> <b>5.B</b> The power steering is not working.*</p> <p>*A steering wheel that is difficult to turn (mostly when the vehicle is stopped) may be a sign that the power steering is not working.</p>
<p><b>Part covered</b></p> <ul style="list-style-type: none"> <li>▶ The steering column</li> </ul> <p>Check the solidity of the steering column.</p>	<p><b>In the driver's compartment</b></p> <ul style="list-style-type: none"> <li>▶ Try to move the steering wheel in all directions.</li> </ul> 	<p> <b>5.A</b> The steering column moves in relation to its normal position and there is a danger of separation.</p> <p> <b>5.1</b> The steering column moves in relation to its normal position.</p>

## 5 - STEERING

Parts covered and purpose of the inspection	Where and how to check	Categories of observable defects
<p><b>Part covered</b></p> <ul style="list-style-type: none"> <li>▶ The steering wheel</li> </ul> <p>Check the adjustment and solidity of the steering wheel.</p>	<p><b>In the driver's compartment</b></p> <ul style="list-style-type: none"> <li>▶ Try to move the steering wheel in all directions.</li> <li>▶ If the steering wheel's position is adjustable, make sure it remains locked in the selected position.</li> </ul>	<p> <b>5.A</b> The steering wheel moves in relation to its normal position because it is improperly mounted on the steering column, and there is a danger of separation.</p> <p> <b>5.1</b> The adjustable steering wheel does not remain locked in the selected position.</p>

## 6 - WINDSHIELD WIPER/WASHER

Parts covered and purpose of the inspection

Where and how to check

Categories of observable defects

**Important: The requirements concerning the windshield wipers and washer must be considered at all times, and not only in bad weather.**

**Parts covered**

► The windshield wipers  
Check for the presence, condition and working order of the windshield wipers.



**In the driver's compartment**

1. Check for the presence of windshield wipers.
2. Switch on the wipers.
3. Check the effectiveness of the wiper blades.

**Note:** Effective wiper blades should sweep the windshield so as to remove any dirt or obstructive material and ensure sufficient visibility for safe driving.



**6.A  
The wiper on the driver's side:**

- is missing;
- is not working;
- does not sweep the windshield effectively.



**6.1  
The wiper on the passenger's side:**

- missing;
- not working;
- does not sweep the windshield effectively.

**Part covered**

► The windshield washer system  
Check the working order of the windshield washer system.

**In the driver's compartment**

1. Switch on the windshield washer system.
2. Check whether the windshield washer system sprays washer fluid onto the windshield.

**Note:** An effective windshield washer system should spray enough washer fluid to the appropriate areas on the windshield so that cleaning provides sufficient visibility for safe driving.





**6.2  
The windshield washer system does not clean the windshield effectively.**

For example, the washer fluid spray nozzle is improperly adjusted or blocked, or little or no washer fluid sprays out when the spray is activated.



## 7 - EMERGENCY MATERIAL

Parts covered and purpose of the inspection	Where and how to check	Categories of observable defects
<p>Covers all vehicles wider than 2 metres</p> <p><b>Parts covered</b></p> <ul style="list-style-type: none"> <li>▶ Flares, triangle reflectors or lamps</li> </ul> <p>Check for the presence of emergency equipment in the vehicles covered.</p> <p><b>Note:</b> All vehicles requiring a Class 1 licence and most vehicles requiring a Class 3 licence are wider than 2 metres.</p>	<p><b>In the cab or the cargo space</b></p> <ul style="list-style-type: none"> <li>▶ Make sure there are at least three flares, three triangle reflectors* or three lamps.</li> </ul> <div data-bbox="381 412 605 480" data-label="Image"> </div> <p><i>*The Regulation respecting vehicles used for the transportation of school children specifies that school buses must be equipped with three triangle reflectors.</i></p> <div data-bbox="425 605 560 758" data-label="Image"> </div> <p><b>Important:</b> Flares may not be used in the case of vehicles carrying flammable or explosive materials.</p> <p><b>Make sure you have the right equipment for the vehicle you are driving!</b></p>	<div data-bbox="640 317 681 362" data-label="Image"> </div> <p>Offence* if the vehicle is not equipped with at least three flares, three triangle reflectors or three lamps.</p> <p><i>*Under section 225 of the Highway Safety Code.</i></p>

## 7 - EMERGENCY MATERIAL

Parts covered and purpose of the inspection	Where and how to check	Categories of observable defects
<p>Covers all vehicles in which it is mandatory to carry a first aid kit (school buses, paratransit vehicles, etc.)</p> <p><b>Parts covered</b></p> <ul style="list-style-type: none"> <li>▶ The first aid kit and its mountings.</li> </ul> <p>Check to make sure the first aid kit is securely mounted and accessible.</p>	<p><b>Inside the vehicle</b></p> <ul style="list-style-type: none"> <li>▶ Check whether the kit is accessible.</li> <li>▶ Make sure the kit is securely attached.</li> </ul>  <p><b>Note:</b> Checking the contents of the first aid kit is not required as part of the circle check. We suggest, however, that you check the contents if you suspect something may be missing.</p>	<p> <b>7.1</b> The first aid kit is not securely mounted or difficult to access.</p>

## 7 - EMERGENCY MATERIAL

Parts covered and purpose of the inspection	Where and how to check	Categories of observable defects
<p>Covers all vehicles for which it is mandatory to carry a chemical fire extinguisher (school buses, paratransit vehicles, certain vehicles transporting dangerous substances, etc.)</p> <p><b>Parts covered</b></p> <ul style="list-style-type: none"> <li>▶ The chemical fire extinguisher and its mountings</li> </ul> <p>Check the extinguisher, its mountings and whether it is accessible.</p> 	<p><b>Inside the vehicle</b></p> <ul style="list-style-type: none"> <li>▶ Check whether the extinguisher is accessible.</li> <li>▶ Make sure the extinguisher is securely attached.</li> <li>▶ Read the pressure gauge.*</li> </ul> <p>*The needle must point to the zone that indicates the device is in proper working order.</p> 	<p><b>7.2</b></p> <p> The chemical extinguisher is not securely mounted, inadequate* or difficult to access.</p> <p>*A chemical extinguisher is inadequate when it is not equipped with a pressure gauge or on which the pressure gauge indicates "Refill" or "Zero".</p>

## 8 - HEADLIGHTS AND LIGHTS

Parts covered and purpose of the inspection

Where and how to check

Categories of observable defects

**Important:** The requirements concerning lights must be considered at all times, not only at night.

## Heavy Vehicle Lighting and Signalling Devices

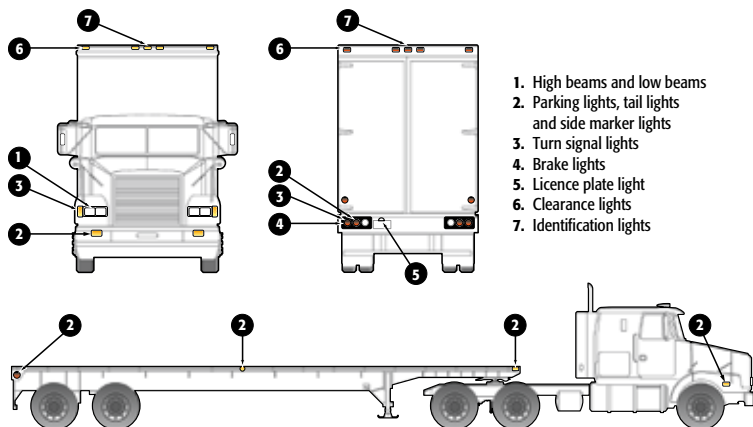

1. High beams and low beams
2. Parking lights, tail lights and side marker lights
3. Turn signal lights
4. Brake lights
5. Licence plate light
6. Clearance lights
7. Identification lights

**Parts covered**

- ▶ The low beams

Check the working order of the low beams.

**In the driver's compartment**

- ▶ Switch on the low beams.

**Outside the vehicle**

- ▶ Check the front right and front left low beams.
- ▶ Make sure the high beams are not activated.







- 8.A**  
None of the low beams work.



- 8.1**  
One of the low beams does not work.

## 8 - HEADLIGHTS AND LIGHTS

Parts covered and purpose of the inspection	Where and how to check	Categories of observable defects
<p><b>Parts covered</b></p> <p>► The parking and tail lights</p> <p>Check the working order of the parking lights (front) and tail lights (rear).</p> <p><b>Note:</b> The <b>front</b> parking lights are only mandatory on vehicles whose width is 2.03 m or less. Tail lights are also called rear parking lights.</p>	<p><b>In the driver's compartment</b></p> <p>► Switch on the parking and tail lights.</p> <p><b>Outside the vehicle</b></p> <p>► Check the parking and tail lights as follows: front right, front left, rear right and rear left of the vehicle or for each vehicle in a combination of vehicles.</p> <p><b>Note:</b> A vehicle complies with the <i>Highway Safety Code</i> if it is equipped with:</p> <p>► one right rear and one left rear tail light; and if the vehicle's width is 2.03 m or less:</p> <p>► one right front and one left front parking light.</p>	<p> <b>8.B</b> None of the rear parking lights work for a single-unit vehicle or the last vehicle in a combination of vehicles.</p> <p> <b>8.1</b> <b>For a single-unit vehicle</b>, one of the rear lights does not work.</p> <p> <b>8.1</b> <b>When the vehicle is hitched</b>, one or both of the rear parking lights do not work for the tractor vehicle or the first semi-trailer of a double road train or one of the parking lights does not work for the last vehicle.</p> <p> <b>8.1</b> One or both front parking lights do not work.</p>



## 8 - HEADLIGHTS AND LIGHTS

## Parts covered and purpose of the inspection

## Parts covered

- ▶ Turn signal lights (flashers)

Check the working order of the front and rear turn signal lights.



## Where and how to check

## In the driver's compartment

- ▶ Switch on the turn signal lights on one side and the other.

## Outside the vehicle

- ▶ Check the turn signal lights as follows: front right, front left, rear right and rear left of the vehicle or for each vehicle in a combination of vehicles.

**Note:** A vehicle complies with the *Highway Safety Code* if it is equipped with:

- ▶ a front right turn signal light and a front left turn signal light;
- ▶ a rear right turn signal light and a rear left turn signal light.

## Categories of observable defects



**8.B**  
**On a single-unit vehicle or the last vehicle of a combination of vehicles:**

- ▶ none of the rear right turn signal lights work;
- ▶ none of the rear left turn signal lights work.



**8.1**  
One or both of the front turn signal lights do not work.







**8.1**  
**When the vehicle is hitched,** one or both of the rear turn signal lights on the tractor vehicle or the first semi-trailer of a double road train does/do not work.



**8.1**  
**On a single-unit vehicle** with a GVWR of less than 4,500 kg or on the last vehicle of a combination of vehicles, where that vehicle has a GVWR of less than 4,500 kg, one or both of the turn signal lights does/do not work.

## 8 - HEADLIGHTS AND LIGHTS

Parts covered and purpose of the inspection	Where and how to check	Categories of observable defects
<p><b>Parts covered</b></p> <ul style="list-style-type: none"> <li>▶ The brake lights</li> </ul> <p>Check the working order of the brake lights.</p> <p><b>Important:</b> Carry out this check when it is safe to do so, for example:</p> <ul style="list-style-type: none"> <li>▶ a second person is available to assist the driver;</li> <li>▶ installations allow the driver to see the reflection of the brake lights.</li> </ul>	<p><b>From inside the vehicle:</b></p> <ol style="list-style-type: none"> <li>1. Press on the brake pedal.</li> <li>2. Make sure the brake lights switch on.</li> </ol> <p><b>Carry out this check by following the proposed methods for greater safety!</b></p>  <p><b>Note:</b> A vehicle complies with the <i>Highway Safety Code</i> if it is equipped with:</p> <ul style="list-style-type: none"> <li>▶ one rear left brake light;</li> <li>▶ one rear right brake light.</li> </ul>	<p> <b>8.B</b> None of the brake lights switch on for a single-unit vehicle or for the last vehicle of a combination of vehicles.</p> <p> <b>8.1</b> <b>For a single-unit vehicle,</b> one one of the brake lights does not switch on.</p> <p> <b>8.1</b> <b>When the vehicle is hitched,</b> one or both of the brake lights do not switch on for the tractor vehicle or the first semi-trailer of a double road train or one of the brake lights does not switch on for the last vehicle.</p> <p><b>Note:</b> For a vehicle with with two or more brake lights on each side, there is no defect if at least one of the lights on each side switches on.</p>

## 8 - HEADLIGHTS AND LIGHTS

Parts covered and purpose of the inspection	Where and how to check	Categories of observable defects
<p><b>Part covered</b></p> <ul style="list-style-type: none"> <li>▶ The rear licence plate light</li> </ul> <p>Check the working order of the light illuminating the licence plate.</p>	<p><b>Outside and at the rear of the vehicle</b></p> <ul style="list-style-type: none"> <li>▶ Check the licence plate light.</li> </ul> <p><b>Note:</b> A vehicle complies with the <i>Highway Safety Code</i> if it is equipped with a white light located so as to illuminate the rear licence plate.</p>	<p> <b>8.1</b> The rear licence plate light is not working.</p>

**In the case of a school bus, in addition to the inspections listed above, it is mandatory to check the working order of the alternately flashing lights on the stop sign, the flashing red lights and the alternately flashing yellow warning lights. See sections 20.7, 20.8 and 20.9.**

## 9 - TIRES

Parts covered and purpose of the inspection

Where and how to check

Categories of observable defects

**Important: Only tires on a weight-bearing axle must be checked. However, checking the tires on an auxiliary lift axle is also recommended, even if there are no plans to use them.**

**Parts covered**

- ▶ The grooves in the tread
- Check the condition of the tread.



On the tires on both sides of the vehicle

- ▶ Check the depth of the grooves in the tread.

**Note:** The tread wear indicator is set at 1.6 mm. It can be found facing the wear indicator marker.

For a tire on the steering axle of a motor vehicle with a GVWR or 4,500 kg or more:



**9.A**

The depth of two adjacent grooves is equal to or less than the tread wear indicator.

**For all tires:**



**9.1**

A tire's tread wear indicator touches the roadway or the depth of a groove is equal to or less than the tread wear indicator.

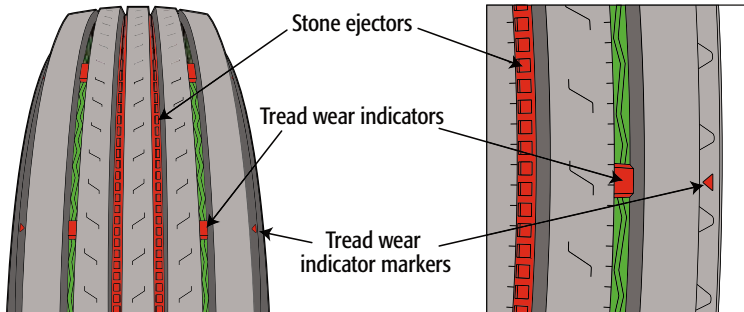

## 9 - TIRES

## Parts covered and purpose of the inspection

## Part covered

- ▶ The tread and the sidewall
- Check the tread and sidewall of all tires.

## Where and how to check

## On the tires on both sides of the vehicle

Check the general condition of the tires:

- ▶ wear;
- ▶ presence of foreign material;
- ▶ damage;
- ▶ bulging.



**Recommendation:** It may be difficult to see that one of the dual tires is flat when the second tire in the same wheel assembly is in good condition. Thus, to check whether one of the dual tires is flat, it is recommended to strike it with a hammer or similar object.



**Note:** In the case of retreads, a separation 6 mm wide or less is considered normal.

## Categories of observable defects

## When a single tire or both dual tires on the same wheel assembly show:



9.B

A foreign body embedded in the tread or sidewall that could cause a puncture.



9.C

A cut, wear or any other damage that causes the cord or steel belt to be exposed.

## When one of the dual tires on the same wheel assembly shows:



9.2

Foreign material embedded in the tread or sidewall that could cause a puncture.



9.3

A cut, wear or any other damage that causes the cord or steel belt to be exposed.

## For all tires:



9.D

A tire touches a fixed component of the vehicle.



9.D

A tire shows an air leak or is flat.



9.D

A tire shows a bulge related to a carcass defect.



9.4



A tire shows abnormal deformation.





9.4

The tread or rubber compound of the sidewall is separated from the carcass of a tire.

## 9 - TIRES

Parts covered and purpose of the inspection	Where and how to check	Categories of observable defects
<p><b>Parts covered</b></p> <ul style="list-style-type: none"><li>▶ The tire valves</li></ul> <p>Check the condition of the tire valves.</p>	<p><b>On the tires around the vehicle</b></p> <ul style="list-style-type: none"><li>▶ Inspect the tire valves.</li></ul> 	<p> <b>9.5</b> The tire valve is worn or damaged (e.g. scraped or cut).</p>

## 10 - DOORS AND OTHER OPENINGS

Parts covered and purpose of the inspection	Where and how to check	Categories of observable defects
<p><b>Parts covered</b></p> <ul style="list-style-type: none"> <li>▶ Cab doors</li> </ul> <p>Check whether the driver's side door opens without any difficulty. Check whether all cab doors are completely engaged when they are closed.</p> 	<p><b>From outside and inside the vehicle</b></p> <ul style="list-style-type: none"> <li>▶ Open and close the door giving access to the driver's compartment (driver's side door).</li> <li>▶ Check whether all cab doors remain engaged.*</li> </ul> <p>*Only the doors designed to allow passengers to board and unboard the vehicle are covered. The sleeper berth doors are not included.</p> <p><b>Note:</b> It is not necessary to open and close every door other than the driver's side door. Simply make sure they are completely engaged.</p> <p>If a door does not appear to be completely engaged, applying pressure on it may suffice to check whether it can engage completely. If in doubt, open and close the door again to make sure it engages completely.</p>	<p> <b>10.A</b> One of the cab doors does not engage completely.</p> <p> <b>10.1</b> The driver's side door does not open or is difficult to open from both inside and outside the vehicle.</p>

## 10 - DOORS AND OTHER OPENINGS

Parts covered and purpose of the inspection

Where and how to check

Categories of observable defects

In the case of buses or motor coaches, the following checks must be performed in addition to the preceding checks.

Covers buses

**Parts covered**

- ▶ Emergency exits (doors, windows, roof hatch)
- ▶ Emergency door warning buzzer or light

Check whether the emergency exits are accessible.

Check the condition of the emergency door and the warning buzzers or lights (depending on whether the bus is equipped with one or two warning systems).

**Inside the vehicle**

- ▶ Check whether the emergency exits are accessible.
- ▶ Open the emergency doors and make sure the warning buzzer or light is working.

**10.B**

The emergency exit is obstructed.\*

\*Any object or installation that hampers access to the emergency exit is considered an obstruction.

**10.C**

An emergency door is inadequate or the warning buzzer or light is inoperative.\*\*

\*\*There is a major defect as soon as a warning buzzer or light does not work.



## 11 - GLASS AND MIRRORS

Parts covered and purpose of the inspection	Where and how to check	Categories of observable defects
<p><b>Part covered</b></p> <ul style="list-style-type: none"> <li>▶ The windshield</li> </ul> <p>Check the condition of the windshield.</p>	<p><b>In the driver's compartment</b></p> <ul style="list-style-type: none"> <li>▶ Sit in the driver's seat.</li> <li>▶ Inspect the windshield and make sure its condition (e.g. transparency, damage or cracks) does not hamper visibility while driving.</li> </ul> <p><b>Note:</b> For the best visibility, we suggest you clear the dashboard surface and windshield of any object that could obstruct the field of vision.</p>	<p> <b>11.1</b></p> <p>The windshield is tarnished, cloudy or broken in a way that reduces the driver's vision of the road or road signs and signals.</p>

## 11 - GLASS AND MIRRORS

Parts covered and purpose of the inspection	Where and how to check	Categories of observable defects
<p><b>Parts covered</b></p> <ul style="list-style-type: none"> <li>▶ The side windows of the driver's compartment</li> </ul> <p>Check the condition of the side windows on each side of the driver's compartment.</p>	<p><b>In the driver's compartment</b></p> <ul style="list-style-type: none"> <li>▶ Sit in the driver's seat.</li> <li>▶ Inspect the side windows on each side of the driver's compartment to make sure their condition does not hamper visibility while driving.</li> <li>▶ Check for transparency and any damage, cracks or obstructions in front of or on the window (e.g. an opaque sticker).</li> </ul>	<p><b>11.1</b></p> <p><b>!</b> A side window on either side of the driver's compartment is tarnished, cloudy, obstructed, crazed or cracked to the point of reducing the driver's vision of the road or road signs and signals.</p>
<b>Important! Additional checks</b>		
<p><b>School buses and minibuses</b></p> <p>Also check the condition of the side windows on both sides and directly behind the driver's compartment.</p> 	<p><b>School buses and minibuses</b></p> <ul style="list-style-type: none"> <li>▶ Also inspect the side windows directly behind the driver's compartment to make sure their condition does not hamper visibility while driving.</li> <li>▶ Check for transparency and any damage, cracks or obstructions in front of or on the window (e.g. an opaque sticker).</li> </ul>	<p><b>School buses and minibuses:</b></p> <p><b>11.4</b></p> <p><b>!</b> A side window on either side and directly behind the driver's compartment is tarnished, cloudy, obstructed, crazed or cracked to the point of reducing the driver's vision of the road or road signs and signals.</p>

## 11 - GLASS AND MIRRORS

## Parts covered and purpose of the inspection

## Parts covered

- ▶ Outside rearview mirrors

## Covers all outside rearview mirrors

Check the solidity of the rearview mirrors and whether they show any sharp edges.



## Covers mandatory outside rearview mirrors only:

Check for the presence and condition of the mandatory outside rearview mirrors.\*

\*Mandatory rearview mirrors:

**All vehicles must be equipped** with an outside rearview mirror on both sides of the vehicle.

**All school buses and minibuses must also be equipped** with a front-mounted convex outside mirror on both sides of the vehicle.

## Where and how to check

## For all outside rearview mirrors

## From outside and inside the vehicle

- ▶ Inspect every outside rearview mirror and their mountings.
- ▶ Make sure they are securely mounted.
- ▶ Make sure no component of any mirror shows a risk of becoming detached or causing injury (from a sharp edge, for example).

## Mandatory mirrors

## From outside the vehicle and inside the driver's compartment

- ▶ Make sure the vehicle is equipped with the mandatory mirrors.
- ▶ Check their general condition.
- ▶ Make sure that each mirror is positioned for safe driving and that it remains in that position.

## Categories of observable defects

## All outside rearview mirrors



11.3

An **outside rearview mirror is not securely mounted** or shows a **sharp edge**.\*

\*A sharp edge means a pointed or cutting edge that could injure someone riding in the vehicle or a pedestrian.

## Mandatory mirrors



11.2

A **mandatory mirror is missing, broken, cracked or tarnished**.



11.2

A **mandatory outside mirror cannot be adjusted to the desired position or does not remain in the selected position**.

## 12 - WHEELS, HUBS AND FASTENERS

Parts covered and purpose of the inspection

Where and how to check

Categories of observable defects

Only wheels on weight-bearing axles must be checked. For increased safety, however, it is also recommended to check the wheels on the auxiliary lift axle, even if there are no plans to use it during the trip.

## Spoke Wheel

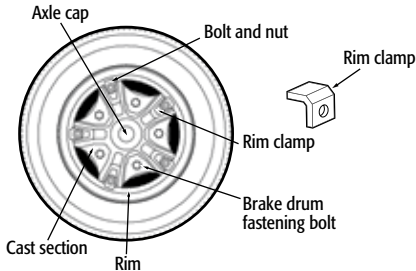

## Parts covered

- The wheels (wheel; on a spoke wheel: disc, rims and spokes [cast section])

Check the condition of the disc or spoke wheels.

## Around the vehicle

- Inspect the visible parts of the wheels (on a spoke wheel: spokes, discs and rims; on a disc wheel: the entire wheel, especially around the bolts).



Example of a spoke wheel



Example of a disc wheel



## 12.C

A wheel is cracked or broken or shows an indication of repair or welding.



## 12.C

One of the stud holes is widened or oval-shaped.

## 12 - WHEELS, HUBS AND FASTENERS

## Parts covered and purpose of the inspection

## Where and how to check

## Categories of observable defects

**Parts covered**

- ▶ Wheel fasteners (bolts, wheel rim clamps, wheel studs and nuts)

Check for the presence and condition of the wheel fasteners.

**Around the vehicle**

- ▶ Inspect the wheel fasteners.

**12.B**

A wheel fastener is missing, cracked, broken or not securely fixed.

**Parts covered**

- ▶ Wheel bearings

Check for leaks (seals) and the oil level in the wheel\* hubs.



Wheel with an oil-lubricated hub



Wheel with grease-lubricated hub

\*The wheel hubs are not required to have an oil level sight glass. The oil level must only be checked if the hub is equipped with a sight glass. Moreover, if an axle cap covers the wheel hub, it does not have to be removed to check the oil level.

**On the wheels around the vehicle**

- ▶ Check the lubricant level through the hub sight glass if so equipped (do not remove the filler cap).

**Note:** A sight glass is generally found on the wheels of the steer axle of a heavy vehicle or the wheels of some trailers and semi-trailers.

- ▶ Check for any traces of oil or grease on the wheels or on the ground under the wheel hubs.

**Important:**

- ▶ Oil or grease leakage from the wheel hub indicates that the wheel bearings may not be sufficiently lubricated.
- ▶ Not enough oil or grease may cause the wheel to come off the vehicle.

**Be vigilant!**

**12.A**

Wheel bearing lubricant is not visible through a sight glass.

**12.1**

Wheel bearing lubricant is below the minimum level when visible through a sight glass.

**Regardless of whether the wheel hub is equipped with a sight glass:**

**12.A**



Wheel bearing lubricant is absent.

**12.1**

There is wheel bearing lubricant leakage other than sweating.

**Note:** The leak may be caused by a broken, missing or improperly secured plug, filler cap or axle cap, improperly tightened axle cap bolts or a damaged seal.

## 12 - WHEELS, HUBS AND FASTENERS

Parts covered and purpose of the inspection	Where and how to check	Categories of observable defects
<p><b>Parts covered</b></p> <ul style="list-style-type: none"> <li>▶ The spare wheel support and fasteners</li> </ul> <p>Check the solidity of the spare wheel support and fasteners.</p>	<p><b>Behind the cab or under the vehicle</b></p> <ul style="list-style-type: none"> <li>▶ Inspect the visible parts of the spare wheel support and fasteners.</li> </ul>  <p><b>Important:</b> You are not required to go under the vehicle to check the spare wheel support fasteners. You only have to visually check the condition of the support and whether it appears to securely hold the spare wheel when mounted.</p>	<p><b>12.2</b></p> <p> The spare tire support or fasteners cannot retain the solidly fixed spare wheel.</p>

## 13 - SEAT

## Parts covered and purpose of the inspection

**Part covered**

- ▶ The driver's seat

Check the general condition and adjustment of the driver's seat.



**Note:** The other seats in vehicles used to carry passengers are covered in Section 20 of this chapter.

**Part covered**

- ▶ The driver's seat belt (anchorage, buckle, retractor and locking mechanism)

Check for the presence, condition and working order of the seat belt.



## Where and how to check

**In the driver's compartment**

- ▶ Check the general condition of the seat.
- ▶ Sit in the seat:
  1. Make the necessary adjustments for safe driving, if required.
  2. After the seat has been adjusted, make sure the seat remains locked in position.

**In the driver's compartment – driver's seat**

- ▶ Inspect the components of the driver's seat belt.
- ▶ Buckle and unbuckle the seat belt to make sure it is in proper working order.

## Categories of observable defects

**13.1**

The driver's seat is inadequate\* or does not remain locked in position.

\*A seat is inadequate if it is not in proper working order to the point of being unsafe.

**13.A**

The driver's seat belt is missing, modified or inadequate.\*

\*A seat belt is considered inadequate if it is not in proper working order.

## 14 - SUSPENSION

Parts covered and purpose of the inspection

Where and how to check

Categories of observable defects

**Only the suspension components on weight-bearing axles are required to be checked.**

Covers all types of suspension

**Parts covered**

► U-Bolts mounting the axle to the road vehicle or components for positioning the axle or wheel to the vehicle (e.g. torque rod and suspension brackets).

Check whether there is any movement of the axles and wheels from their normal position.

**Around the vehicle**

► As you approach the vehicle, check the parallelism of the wheels and the position of the axles to make sure there are no signs of any movement of the axle or wheels from their normal position.

► Inspect the U-Bolts by positioning yourself to see as many suspension parts as possible (when they are accessible).



**14.C**  
A U-Bolt is missing, improperly mounted, cracked or broken.



**14.G**  
The wheels are not parallel.



**14.G**  
One of the axles or wheels has moved from its normal position.

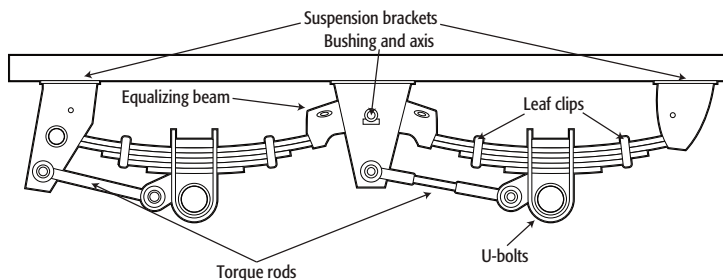



## 14 - SUSPENSION

Parts covered and purpose of the inspection

Where and how to check

Categories of observable defects

In the case of metal or composite spring suspensions, the following check must be performed in addition to the checks in the preceding section.

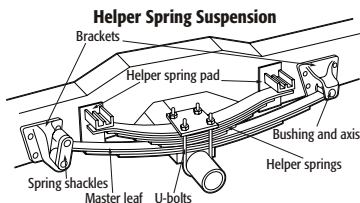

Covers metal or composite spring suspensions

## Parts covered

## ▶ Leaf springs



## ▶ Coil springs

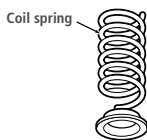

## ▶ Torsion bars

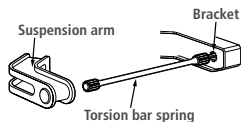

Check for the presence, condition and position of the leaf springs and coil springs as well as the condition of the torsion bars.

## Approaching the vehicle

▶ Observe the vehicle's general condition to detect any sign of complete or partial sagging.

## Around the vehicle

▶ Position yourself to see as many suspension parts as possible (when they are accessible), to check the leaf springs, the coil springs and the torsion bars.



## 14.A

A master leaf is missing or broken.



## 14.A

25% or more of the leaf springs of an assembly are broken or missing.



## 14.D

A composite leaf spring (e.g. fibreglass) is cracked along 75% of its length or has intersecting cracks.\*

\* "Intersecting cracks" means two cracks that cross each other at a perpendicular angle.



## 14.E

A coil spring is out of place and comes into contact with a moving part.



## 14.F

A coil spring is broken to the point where the vehicle sags completely where this spring is located.



## 14.F

A torsion bar is broken.



## 14.1

A leaf spring other than a master leaf or a coil spring is broken.

## 14 - SUSPENSION

Parts covered and purpose of the inspection

Where and how to check

Categories of observable defects

In the case of rubber pad suspensions (often found on concrete mixers), the following check must be performed in addition to the checks in 14.1.

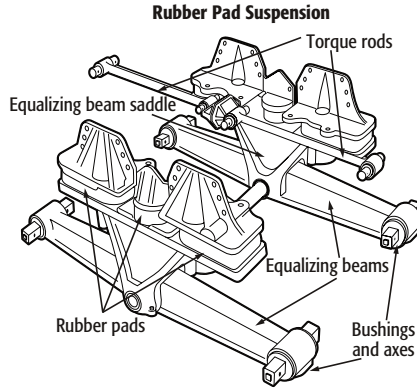

Covers rubber pad suspensions

**Parts covered**

- ▶ Rubber pads

Check for the presence and condition of the rubber pads.

**Around the vehicle**

- ▶ Position yourself to check the suspension's rubber pads.



**14.A**

A rubber pad is missing or broken.

## 14 - SUSPENSION

Parts covered and purpose of the inspection

Where and how to check

Categories of observable defects

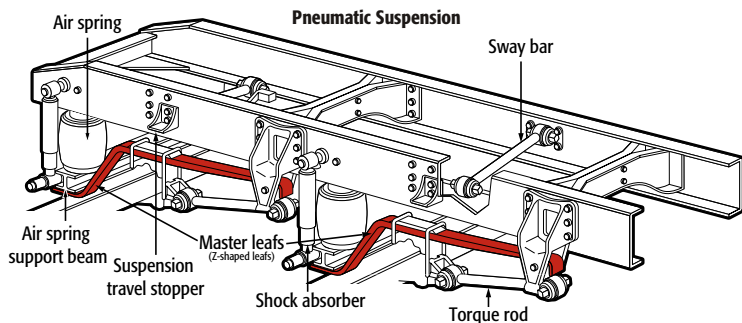

In the case of air suspensions, the following checks must be performed in addition to the checks in 14.1.

Covers air suspensions

#### Parts covered

- ▶ The air suspension system's lines and air springs. Check the vehicle balance. Check the condition of the air springs and whether there are any air leaks in the system.



#### Around the vehicle

- ▶ Make sure air is circulating in the suspension lines and that the air springs are properly inflated. Generally speaking, the suspension lines are supplied when the air pressure gauge reading reaches 483 kPa (70 psi).
- ▶ Check the condition of each air spring.
- ▶ Listen for air leaks from the suspension supply lines.
- ▶ Check the vehicle balance if no suspension components are accessible.

**Note:** You must start the vehicle in order to start the compressor and determine whether an air leak is a major defect.



#### 14.B

An air leak in the suspension system cannot be compensated for by the compressor when the engine is idling.



#### 14.B

An air spring is missing or deflated.



#### 14.2

The suspension system shows an air leak.



#### 14.2





An air spring is damaged to the point that the cord is exposed.

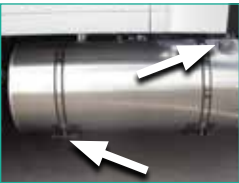

#### 14.2

An air spring shows indications of a repair.

## 15 - FUEL SYSTEM

Parts covered and purpose of the inspection	Where and how to check	Categories of observable defects
<p><b>Parts covered</b></p> <ul style="list-style-type: none"> <li>▶ The road vehicle's fuel tank</li> <li>▶ The gasoline or diesel fuel tank filler cap</li> </ul> <p>Check the fuel tank fasteners to make sure it is securely mounted. Check for the presence of the gasoline or diesel fuel tank filler cap.</p> <p><b>Note:</b> Vehicles are often equipped with more than one fuel tank. They must all be checked.</p>	<p><b>Outside the vehicle</b></p> <ul style="list-style-type: none"> <li>▶ Inspect the fasteners for each fuel tank.</li> <li>▶ Make sure every fuel tank has a filler cap.</li> </ul> 	<p> <b>15.A</b> The fuel tank is not securely fixed and there is a risk of separation.</p> <p> <b>15.B</b> The gasoline or diesel fuel tank does not have a filler cap.</p>
<p><b>Part covered</b></p> <ul style="list-style-type: none"> <li>▶ The road vehicle's fuel tank(s)</li> </ul> <p>Check the fuel tank(s) for leaks.</p>	<p><b>Outside the vehicle</b></p> <ul style="list-style-type: none"> <li>▶ Check for any liquid on the ground.</li> <li>▶ Inspect every fuel tank to make sure there are no fuel leaks, other than oozing.</li> </ul> <p><b>Recommendation:</b> Trailers and semi-trailers may also be equipped with tanks to supply accessory compartments (e.g. a refrigeration compartment). As a safety precaution, we suggest that you check them even if not required in the circle check.</p>	<p> <b>15.C</b> A fuel tank shows a leak other than oozing.</p> <p> <b>15.C</b> There is a fuel leak other than oozing along the fuel delivery system.</p> <p><b>Note:</b> Such leaks are detected by the presence of fuel on the ground.</p>

## 16 - EXHAUST SYSTEM

## Parts covered and purpose of the inspection

**Parts covered**

- ▶ Exhaust system components

Check the condition of the exhaust system components.



**Note:** To check whether there is a major defect, the vehicle's engine must be running.

## Where and how to check

**In the cab**

- ▶ If you detect the odour of exhaust gases, check whether there is a hole in the floorboard.

**Around the vehicle**

- ▶ Check for any odours that may come from the engine's exhaust system.
- ▶ Inspect the visible components of the exhaust system to detect any leaks caused by defective joints, cracks or holes other than those originally provided by the manufacturer.
- ▶ Check for any noise coming from the exhaust system.
- ▶ Check for any trace of soot not normally found on an exhaust system.

**Note:** The exhaust system is composed of many components that can break or come loose, thereby indicating an air leak (e.g. a muffler, exhaust pipes, brackets, fasteners and heat shields). Furthermore, you can sometimes hear or smell a defect before you actually see it.

**Be vigilant!**

## Categories of observable defects





**16.A**  
Leakage of exhaust gases enters the passenger compartment when the floorboard is perforated.



**16.1**  
Leakage of exhaust gases other than from the holes originally provided by the manufacturer of the exhaust system.

## 17 - ELECTRIC BRAKE SYSTEM

Parts covered and purpose of the inspection	Where and how to check	Categories of observable defects
<b>Certain trailers are equipped with this type of brake system.</b>		
<p><b>Parts covered</b></p> <ul style="list-style-type: none"> <li>▶ Electric brake system cables and connections</li> </ul> <p>Check the electric cables and connections of the brake system.</p> 	<p><b>Outside the vehicle</b></p> <ul style="list-style-type: none"> <li>▶ Inspect the visible parts of the electric cables and connections (at the connection and attachment points).</li> </ul> <p><b>Note:</b> The attachment point fastens the electric cables to the vehicle structure, for example, it prevents the cable from being slack.</p>	<p> <b>17.1</b> An electric cable or connector is improperly fixed at a connection or attachment point.</p>
<p><b>Part covered</b></p> <ul style="list-style-type: none"> <li>▶ The trailer's service brake</li> </ul> <p>Check the effectiveness of the electric brake system.</p>	<p><b>In the driver's compartment</b></p> <ol style="list-style-type: none"> <li>1. Start the vehicle and drive slightly forward.</li> <li>2. Press the brake pedal.</li> <li>3. Check whether the vehicle stops quickly.</li> </ol>	<p> <b>17.A</b> There is a significant reduction in the braking capacity.</p>

## 18 - HYDRAULIC BRAKE SYSTEM

## Parts covered and purpose of the inspection

**Part covered**

- ▶ The master cylinder reservoir
- Check the service brake fluid level.



## Where and how to check

**In the engine compartment**

- ▶ Check the fluid level in the master cylinder using the indicator on the reservoir. If there is no indicator, open the reservoir to check the fluid level.

**Important:** Some reservoirs require a tool to be opened. If a reservoir has two caps, both compartments must be checked. In the case of a combination of vehicles in which each vehicle is equipped with hydraulic brakes, the reservoir of each vehicle must be checked.

**Recommendation:**

If you have to open the master cylinder reservoir because you cannot check the fluid level from the exterior, certain precautions are recommended. In particular, clean all around the opening to avoid introducing any contaminants into the fluid, properly replace the seal, and make sure to put the cap back on tightly.

## Categories of observable defects



**18.A**

The master cylinder fluid level is less than one-quarter of the maximum level prescribed by the manufacturer.

**18.1**







The master cylinder fluid level is lower than the minimum level prescribed by the manufacturer or, if there is no indicator, is at more than 12.5 mm below the edge of the filler opening.

## 18 - HYDRAULIC BRAKE SYSTEM



Parts covered and purpose of the inspection	Where and how to check	Categories of observable defects
<p><b>Part covered</b></p> <p>► The power brake</p> <p>Check the working order of the power brake.</p> <p><b>Important:</b> The power brake cannot be checked using one of these methods if it is hydraulically assisted.</p>	<p><b>From the driver's compartment</b></p> <p><b>Vacuum brake booster</b></p> <ol style="list-style-type: none"> <li>1. Let the engine run for a few seconds.</li> <li>2. Stop the engine.</li> <li>3. Pump the brake pedal several times.</li> <li>4. Apply average pressure to the brake pedal.</li> <li>5. Restart the engine while maintaining pressure on the pedal.</li> <li>6. Check the movement of the brake pedal.</li> </ol> <p><b>From the driver's compartment</b></p> <p><b>Hydraulic brake booster (electric pump)</b></p> <ol style="list-style-type: none"> <li>1. Turn off the engine if it is running.</li> <li>2. Apply average pressure to the brake pedal.</li> <li>3. Listen to hear if the electric pump is working.</li> </ol> <p><b>Note:</b> Some straight-body trucks and most school buses are equipped with a hydraulic brake booster (electric pump).</p>	<p><b>Vacuum brake booster</b></p> <p> <b>18.C</b> The brake pedal does not go down slightly after restarting the engine.</p> <p><b>Hydraulic brake booster (electric pump)</b></p> <p> <b>18.C</b> The electric pump does not work when the engine is not running.</p>



## 18 - HYDRAULIC BRAKE SYSTEM

Parts covered and purpose of the inspection	Where and how to check	Categories of observable defects
<p><b>Part covered</b></p> <ul style="list-style-type: none"> <li>▶ The service brake warning light</li> </ul> <p>Check the working order of the service brake warning light.</p> 	<p><b>From the driver's compartment</b></p> <p>The check <b>must</b> be performed as follows:</p> <ol style="list-style-type: none"> <li>1. Release the parking brake.*</li> <li>2. Turn the ignition key to the "ON" or "START" position.</li> <li>3. Check whether the warning light switches on.</li> <li>4. If it is not already running, start the engine.</li> <li>5. Check whether the warning light switches off.</li> </ol> <p>*Only required if the service brake warning light is also the parking brake warning light.</p>	<p> <b>18.3</b> The warning light does not switch on when the ignition key is in the "ON" or "START" position.</p> <p> <b>18.3</b> The warning light stays on when the engine is running.</p>
<p><b>Part covered</b></p> <ul style="list-style-type: none"> <li>▶ Braking equipment</li> </ul> <p>Check the pressure and for leaks in the braking equipment.</p> 	<p><b>From the driver's compartment</b></p> <ol style="list-style-type: none"> <li>1. As the engine is running, press down hard (more than for a normal braking manoeuvre) on the brake pedal for at least 10 seconds.*</li> <li>2. Check the movement of the pedal.</li> </ol> <p>*Note that for some vehicles equipped with a hydraulic brake booster, this check cannot be performed if the engine is not running.</p>	<p> <b>18.B</b> The brake pedal reaches the floor in less than 10 seconds.</p> <p> <b>18.2</b> The brake pedal reaches the floor in 10 seconds or more.</p> <p> <b>18.B</b> The brake pedal has to be pumped several times to pressurize the circuit, which can be felt by resistance in the pedal.</p>

## 18 - HYDRAULIC BRAKE SYSTEM

Parts covered and purpose of the inspection	Where and how to check	Categories of observable defects
<p><b>Part covered</b></p> <p>► The service brake</p> <p>Check the effectiveness of the service brake.</p>	<p><b>From the driver's compartment</b></p> <ol style="list-style-type: none"> <li>1. Start the vehicle and drive forward slightly.</li> <li>2. Press on the brake pedal.</li> <li>3. Check whether the vehicle stops quickly.</li> </ol>	<p> <b>18.D</b></p> <p>There is a significant reduction in the braking capacity.</p>
<p><b>Part covered</b></p> <p>► The parking brake warning light</p> <p>Check the working order of the parking brake warning light.</p>	<p><b>From the driver's compartment</b></p> <p>Perform the two following checks:</p> <ol style="list-style-type: none"> <li>1. Turn the ignition key to the "ON" or "START" position. Apply the parking brake. Check whether the parking brake warning light switches on.</li> <li>2. Release the parking brake. Check whether the warning light switches off.</li> </ol>	<p> <b>18.4</b></p> <p>The warning light does not switch on when the parking brake is activated.</p> <p> <b>18.4</b></p> <p>The warning light does not switch off when the parking brake is released.</p>



## 18 - HYDRAULIC BRAKE SYSTEM

## Parts covered and purpose of the inspection

**Part covered**

- ▶ The parking brake

Check the effectiveness of the parking brake.



**Note:** The parking brake cannot be checked on certain heavy vehicles equipped with an automatic transmission because the transmission cannot be shifted into gear while the parking brake is engaged.

## Where and how to check

**From the driver's compartment, while the engine is running**

Perform the two following checks:

1. Apply the parking brake. Try to drive the vehicle forward as you apply the following:
  - ▶ **Automatic transmission:** Put the gear shift lever in the "DRIVE" position.
  - ▶ **Manual transmission:** Select the right gear that allows the vehicle to move forward.

Check whether the parking brake maintains the vehicle stationary.

2. Release the parking brake. Slowly drive a few metres forward, watching the wheel rotation in the rearview mirrors.

**Note:** Turning left and right makes it easier to check the wheels on the trailer or semi-trailer in a combination of vehicles.

## Categories of observable defects

**18.5**

The parking brake does not keep the vehicle from moving when the driver tries to drive forward.

**18.5**

The parking brake does not let the wheels turn freely when released.

## 19 - PNEUMATIC BRAKE SYSTEM

Parts covered and purpose of the inspection

Where and how to check

Categories of observable defects

**Important: Precautions for a more thorough inspection:**

- ▶ Make sure the lines in which the air flows are working.
- ▶ Open the suspension lines if equipped with air springs.

**Part covered**

- ▶ Low air pressure warning device(s) (visual, light or buzzer)

Check the working order of the service brake low air pressure warning device(s).



Visual warning device (wigwag)

**In the driver's compartment**

- ▶ Position the switch to the "ON" position and check the pressure gauge.

**If the pressure is above 380 kPa (55psi):**

1. Release the parking brake.\*
2. While checking the pressure gauge(s), pump the brake pedal until the low pressure warning device(s) is/are activated.

\*It is preferable to release the parking brake if the vehicle is not equipped with an anti-compounding brake device to avoid damaging the brake chambers.

**If the pressure is below 380 kPa (55 psi):**

1. Start the engine to increase pressure.
2. While checking the pressure gauges, make sure the warning devices are working until the air pressure in the system reaches at least 380 kPa (55 psi).

**19.A**

None of the low pressure warning devices (visual, light and buzzer) work when the air pressure in the system is below 380 kPa (55 psi).

**Only for vehicles equipped with more than one warning device:****19.1**

The vehicle's low pressure warning buzzer does not work when the air pressure in the system is below 380 kPa (55 psi).

**19.2**

The vehicle's low pressure visual and light warning devices do not work when the air pressure in the system is below 380 kPa (55 psi).

## 19 - PNEUMATIC BRAKE SYSTEM

## Parts covered and purpose of the inspection

**Part covered**

- ▶ The compressor

Check whether the performance of the compressor allows the service brake to work properly.



**Important:** Always release the parking brake to check the performance of the compressor, so that all air brake circuits are engaged.

## Where and how to check

**In the driver's compartment**

The check **must** follow this sequence:

1. Release the parking brake.
2. While the engine is idling, make sure the compressor is working by watching the needle or whether the pressure gauge readings are going up.
3. Press on the brake pedal.
4. Watch the pressure gauges to check whether the compressor can reach and maintain air pressure at the prescribed threshold of 620 kPa (90 psi).

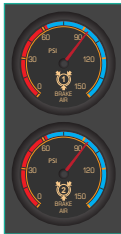

## Categories of observable defects



**19.B**

The air compressor cannot reach or maintain air pressure of at least 620 kPa (90 psi).





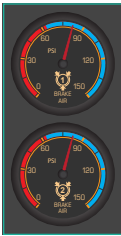

## 19 - PNEUMATIC BRAKE SYSTEM

Parts covered and purpose of the inspection	Where and how to check	Categories of observable defects
<p><b>Part covered</b></p> <p>► The pressure regulator</p> <p>Check the pressure at which the compressor:</p> <p>a) stops and b) starts.</p>	<p><b>Stopping of the compressor</b></p> <p>In the driver's compartment</p> <ol style="list-style-type: none"> <li>1. While watching the pressure gauges, run the engine at about 1,000 rpm until the air pressure stops rising.</li> <li>2. Take an air pressure reading of the pressure gauge(s) once the pressure stops rising.</li> </ol> <div data-bbox="429 491 554 724" data-label="Image"> </div> <p><b>Note:</b> A pressure reading at 1,000 RPM is recommended to obtain an accurate reading of the compressor's performance while limiting fuel consumption.</p>	<p><b>19.3</b></p> <p> The compressor does not switch off when the air pressure is between 805 kPa (117 psi) and 945 kPa (137 psi).</p>

## 19 - PNEUMATIC BRAKE SYSTEM

Parts covered and purpose of the inspection	Where and how to check	Categories of observable defects
	<p><b>Starting of the compressor</b> In the driver's compartment</p> <ol style="list-style-type: none"> <li>1. Release the parking brake.</li> <li>2. With the engine running, watch the pressure gauges.</li> <li>3. Make sure that the pressure indicated by the pressure gauges has stopped increasing.</li> <li>4. Pump the brake pedal until the compressor starts.</li> <li>5. Take a pressure gauge reading.</li> </ol> 	<p><b>19.3</b>   The compressor starts when the pressure is less than or equal to 550 kPa (80 psi).</p>

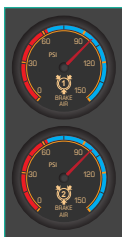

## 19 - PNEUMATIC BRAKE SYSTEM

Parts covered and purpose of the inspection	Where and how to check	Categories of observable defects
<p><b>Part covered</b></p> <p>► The braking equipment</p> <p>Check for leaks.</p>	<p><b>At all times</b></p> <p>Listen for possible air leaks.</p> <p><b>In the driver's compartment</b></p> <p>The check <b>must</b> follow this sequence:</p> <ol style="list-style-type: none"> <li>1. Release the parking brake.</li> <li>2. Run the engine until the air pressure rises to the maximum level in the system.</li> <li>3. Turn off the engine.</li> <li>4. Press the brake pedal all the way down.</li> <li>5. Watch the pressure gauge.</li> <li>6. If there is a continuous drop in air pressure, hold the brake pedal fully depressed for at least 1 minute and evaluate whether the defect is major or minor.</li> </ol> <p><b>Important:</b> At all times, when an air leak is detected, it is necessary to check the severity by going through the sequence outlined above.</p>	<p> <b>Audible air leak</b></p> <p>Minor defect (a) or major defect (b) if the loss of air pressure in one minute exceeds, for a:</p> <p><b>Single-unit vehicle</b> (e.g. a bus, straight-body truck, road tractor)</p> <p> <b>19.4</b> a) 20 kPa (3 psi)</p> <p> <b>19.C</b> b) 40 kPa (6 psi).</p> <p><b>Two-unit vehicle</b> (e.g. a straight-body truck and trailer, tractor trailer)</p> <p> <b>19.4</b> a) 28 kPa (4 psi)</p> <p> <b>19.C</b> b) 48 kPa (7 psi)</p> <p><b>Three-unit vehicle</b> (e.g. a double road train)</p> <p> <b>19.4</b> a) 35 kPa (5 psi)</p> <p> <b>19.C</b> b) 62 kPa (9 psi).</p>







## 19 - PNEUMATIC BRAKE SYSTEM

Parts covered and purpose of the inspection	Where and how to check	Categories of observable defects
<p><b>Part covered</b></p> <ul style="list-style-type: none"> <li>▶ The service brake</li> </ul> <p>Check the effectiveness of the service brake.</p> 	<p><b>In the driver's compartment</b></p> <ol style="list-style-type: none"> <li>1. Start the vehicle and drive forward slightly.</li> <li>2. Press on the brake pedal.</li> <li>3. Check whether the vehicle stops quickly.</li> </ol>	<p> <b>19.D</b></p> <p>There is a significant reduction in the braking capacity.</p>

## 19 - PNEUMATIC BRAKE SYSTEM

Parts covered and purpose of the inspection	Where and how to check	Categories of observable defects
<p><b>Part covered</b></p> <p>► The parking brake</p> <p>Check the effectiveness of the parking brake.</p>  <p><b>Note:</b> The parking brake cannot be checked on certain heavy vehicles equipped with an automatic transmission because the transmission cannot be shifted into gear while the parking brake is engaged.</p> <p>For a combination of vehicles, the parking brake of each vehicle must be checked.</p>	<p><b>From the driver's compartment, with the engine running</b></p> <p>Perform the two following checks to verify the effectiveness of the parking brake.</p> <p><b>Applying the brake</b></p> <ol style="list-style-type: none"> <li>1. Apply the parking brake.</li> <li>2. Try to drive the vehicle forward slightly by applying the following:           <ul style="list-style-type: none"> <li>► <b>for an automatic transmission</b>, put the gear shift lever into the "DRIVE" position.</li> <li>► <b>for a manual transmission</b>, select the right gear that allows the vehicle to move forward.</li> </ul> </li> <li>3. Check whether the parking brake maintains the vehicle stationary.</li> </ol> <p><b>Releasing the brake</b></p> <ol style="list-style-type: none"> <li>1. Release the parking brake.</li> <li>2. Make sure there is enough pressure in the circuit (483 kPa or 70 psi) to completely release the parking brake springs and avoid skewing the results.</li> <li>3. Slowly drive a few metres forward, watching the wheel rotation in the rearview mirrors.</li> </ol> <p><b>Note:</b> Turning left and right makes it easier to check the wheels on the trailer or semi-trailer in a combination of vehicles.</p>	<p> <b>19.5</b> The parking brake does not prevent the vehicle from moving when the driver tries to drive forward.</p> <p> <b>19.5</b> The parking brake does not let the wheels turn freely when released.</p>

## 20 - PASSENGER TRANSPORT

Parts covered and purpose of the inspection

Where and how to check

Categories of observable defects

**Section 20 applies exclusively to inspections of buses and minibuses configured to transport passengers. The parts to be checked are in addition to the parts to be checked listed in the previous sections.**

## Parts covered

- ▶ Stanchions, horizontal bars, grab handles and guard panels
- ▶ Shock-absorbing material on stanchions if provided by the manufacturer

Check the stanchions, horizontal bars, grab handles, guard panels and, if provided by the manufacturer, shock-absorbing material on the stanchions.

## Inside the vehicle

- ▶ From the best location based on the configuration of the vehicle, inspect the relevant parts inside the vehicle. For example, in a vehicle designed to transport more than 24 passengers, go to the central aisle.
- ▶ Also check the shock-absorbing material provided by the manufacturer.



**Note:** Although the circle check only requires sight and sound inspections, if you have any doubts concerning the solidity of any parts inspected, we suggest you apply light pressure to make sure the part is safe.



## 20.1

The stanchions, horizontal bars, grab handles and guard panels are not securely mounted.





## 20.2



Shock-absorbing material on stanchions provided by the manufacturer is missing or inadequate.\*

\*Inadequate means worn or broken to the point of no longer providing protection.





## 20 - PASSENGER TRANSPORT

Parts covered and purpose of the inspection	Where and how to check	Categories of observable defects
<p><b>Parts covered</b></p> <ul style="list-style-type: none"> <li>▶ The floor and steps in the passenger compartment.</li> </ul> <p>Check the condition of the floor and steps.</p> 	<p><b>Outside the vehicle</b></p> <ul style="list-style-type: none"> <li>▶ Inspect the steps before entering the vehicle.</li> </ul> <p><b>Inside the vehicle</b></p> <ul style="list-style-type: none"> <li>▶ Inspect the visible surface of the floor (especially the central aisle and areas between seats).</li> </ul>	<p><b>20.3</b></p> <p>The floor or a step in the passenger compartment is cracked, worked (misshapen) or perforated.*</p> <p>*There is a defect when the condition of the floor poses a danger for the occupants.</p>
<p><b>Part covered</b></p> <ul style="list-style-type: none"> <li>▶ Central aisle and passenger entrance lighting systems</li> </ul> <p>Check the working order of the central aisle and passenger entrance lighting systems.</p>	<p><b>Inside the vehicle</b></p> <ol style="list-style-type: none"> <li>1. Activate the lighting system switch for the central aisle, entrance and exit steps and boarding space.</li> <li>2. Check whether the central aisle, entrance and exit steps and boarding space can be illuminated.</li> </ol> 	<p><b>20.4</b></p> <p>The central aisle, entrance or exit steps or boarding space cannot be illuminated.</p>

## 20 - PASSENGER TRANSPORT

Parts covered and purpose of the inspection	Where and how to check	Categories of observable defects
<p><b>Parts covered</b></p> <ul style="list-style-type: none"> <li>▶ Overhead (top) luggage racks or compartments inside the passenger compartment</li> </ul> <p>Check the solidity and condition of the luggage racks or compartments inside the passenger compartment.</p>	<p><b>Inside the vehicle</b></p> <ul style="list-style-type: none"> <li>▶ Inspect the overhead luggage racks or compartments.</li> <li>▶ Make sure they are securely mounted and can retain luggage safely.</li> </ul> <p><b>Note:</b> Although the circle check only requires a sight and sound inspection, we suggest you apply light pressure on the luggage racks and compartments.</p>	<p> <b>20.5</b> A top luggage rack or compartment is not securely mounted or cannot retain luggage.</p>
<p><b>Parts covered</b></p> <ul style="list-style-type: none"> <li>▶ Passenger seats and benches</li> </ul> <p>Check the passenger seats and benches.</p> 	<p><b>Inside the vehicle</b></p> <p>As you walk up and down the central aisle:</p> <ul style="list-style-type: none"> <li>▶ Inspect the position and general condition of the seats and benches. If there are one-man seats (folding seats), they must also be checked.</li> </ul> <p><b>Note:</b> Although the circle check only requires a sight and sound inspection, if you have any doubts about the solidity of the seats or benches, we suggest you apply light pressure on them to make sure they are safe.</p>	<p> <b>20.6</b> A seat or bench is inadequate.*</p> <p>*A seat or bench is inadequate if it is not in good working order to the point of being unsafe.</p>

## 20 - PASSENGER TRANSPORT

Parts covered and purpose of the inspection	Where and how to check	Categories of observable defects
<p>Covers school buses</p> <p><b>Part covered</b></p> <ul style="list-style-type: none"> <li>▶ The retractable stop sign</li> </ul> <p>Check the condition of the retractable stop sign.</p> 	<p><b>In the driver's compartment</b></p> <ul style="list-style-type: none"> <li>▶ Activate the deployment of the retractable stop sign located on the left side of the driver's compartment.</li> </ul> <p><b>Outside the vehicle</b></p> <ul style="list-style-type: none"> <li>▶ Check the position of the stop sign with respect to the side of the bus.</li> </ul>	<p> <b>20.7</b> The stop sign does not move into a position that is perpendicular to the bus.</p> <p><b>Important:</b> Although a minor defect does not prohibit a vehicle from being operated, the <i>Highway Safety Code</i> requires drivers to turn on the compulsory stop sign to take on or discharge school children or persons under age 18. If the stop sign mechanism is defective and cannot be deployed, the driver may not take on or discharge school children or persons under age 18.<sup>7</sup></p>
<p>Covers school buses</p> <p><b>Parts covered</b></p> <ul style="list-style-type: none"> <li>▶ The alternately flashing lights on the stop sign</li> </ul> <p>Check the working order of the alternately flashing lights on the stop sign.</p>	<p><b>In the driver's compartment</b></p> <ol style="list-style-type: none"> <li>1. Activate the retractable stop sign.</li> <li>2. Check the flashing lights at the top and bottom of the stop sign.</li> </ol> 	<p> <b>20.7</b> One or more alternately flashing lights does/do not switch on when the stop sign is perpendicular to the vehicle.</p>

<sup>7</sup> This is an offence under section 456 of the *Highway Safety Code*. The driver of the vehicle is subject to a fine of \$600 to \$2,000.

## 20 - PASSENGER TRANSPORT

## Parts covered and purpose of the inspection

Covers school buses

## Parts covered

► The flashing red lights  
Check the working order of the flashing red lights.

## Where and how to check

## In the driver's compartment

1. Switch on the flashing red lights.

## Outside the vehicle

2. Check the flashing red lights on the front right, front left, rear right and rear left.



## Categories of observable defects



## 20.8



One or more front and rear flashing red lights does/do not work when switched on.

**Note:** Although a minor defect does not prohibit a vehicle from being operated, the *Highway Safety Code* requires drivers to activate the flashing red lights to take on or discharge school children or persons under age 18.<sup>8</sup>

If both rear flashing lights or both front flashing lights do not work when switched on, the driver may not let on or discharge school children or persons under age 18.

<sup>8</sup> This is an offence under section 456 of the *Highway Safety Code*. The driver of the vehicle is subject to a fine of \$600 to \$2,000.

## 20 - PASSENGER TRANSPORT

Parts covered and purpose of the inspection	Where and how to check	Categories of observable defects
<p>Covers school buses</p> <p><b>Parts covered</b></p> <ul style="list-style-type: none"> <li>▶ The alternately flashing yellow lights</li> </ul> <p>Check the working order of the alternately flashing yellow lights.</p> <p><b>Important:</b> This check must only be performed under safe conditions.</p> <p>Do not attempt to perform the check with any manoeuvres that may be unsafe. In the circle check report, indicate the reason why this check was not performed, if applicable.</p>	<p><b>From inside the vehicle:</b></p> <p><b>In the front:</b></p> <ol style="list-style-type: none"> <li>1. Activate the switch.</li> <li>2. Check the front alternately flashing yellow lights through the convex mirrors.</li> </ol>  <p><b>In the rear:</b></p> <ol style="list-style-type: none"> <li>1. Activate the switch.</li> <li>2. Open the rear door of the bus.</li> <li>3. Safely check the rear alternately flashing yellow lights.</li> </ol>	<p> <b>20.8</b> One or more alternately flashing yellow lights does/do not work when switched on.</p>



# FOR A THOROUGH AND EFFECTIVE INSPECTION

The circle check, as described in the previous pages, meets the minimum standards set out in the *Regulation respecting safety standards for road vehicles*. Its goal is to prevent a vehicle that presents defects that may endanger road users from being put into operation. The inspection must therefore be thorough and well understood.

With this in mind, you can apply the safe 10-step method outlined in the following pages to your circle check. It allows you to completely circle the vehicle to check whether some components or parts need to be adjusted or repaired. Although this method is not mandatory and another method may be as effective, it allows you to meet your obligations quickly and make sure that you are driving a safer vehicle.<sup>9</sup>

<sup>9</sup> The *Circle Check Guide*, available on the website of the Société de l'assurance automobile du Québec, suggests other inspection methods and provides additional information on the circle check.

# TIPS AND RECOMMENDATIONS

Before explaining the suggested circle check method, here are some tips to optimize your efficiency and allow you to conduct the inspection in a safe environment.

## Choose a safe location

First, choose a flat and safe location to park your vehicle in order to conduct the circle check. If your vehicle is close to a roadway, pay close attention to nearby traffic, so you don't jeopardize your safety or the safety of others.

## Make sure the vehicle is stable

From the beginning, you should apply the parking brake to the entire vehicle in order to perform most of the circle check. During the inspection, it may be necessary to release the parking brake on certain vehicles equipped with an air suspension system or air brake system, to allow air intake and ensure an effective inspection. In these situations, it is essential to make sure that the vehicle remains immobile, even if the inspection is carried out on flat ground.

## Access the vehicle using three support points

As a safety precaution, always use three support points to climb onto or off the vehicle, regardless of location. Also avoid climbing onto tires or other parts of the vehicle that are not intended for that purpose.

## Items requiring special attention

Throughout the circle check, pay special attention to possible air leaks from the brake system, suspension system or tires, and fluid leaks on the ground or around wheel hubs or on tanks (e.g. oil, grease or fuel). These generally indicate defects that may have major consequences on the road, such as a flat tire or wheel loss, a braking system malfunction or a break in the suspension.

## Pay attention to your vehicle's overall condition

Remember that the inspection is primarily a sight and sound check of certain accessible parts of the vehicle. Nevertheless, remain attentive to the general condition of the vehicle's parts even if they are not subject to the mandatory circle check. Your vigilance, for example with respect to the operation of the engine, fluid levels, component solidity, part wear or cargo and equipment securement could prevent incidents. Make sure you inform the vehicle's owner or operator of any anomalies you detect.

If you plan on performing some additional checks that require touching certain parts of the vehicle, proceed with great caution. As needed, use gloves as well as tools and equipment such as a pressure gauge, hammer, flashlight, clean rags and a tool to open the power steering reservoir.

## Adapt your method to the vehicle

The circle check method requires that you adapt to the type of vehicle you are inspecting and its parts. Heavy vehicles may have different braking, coupling, steering and emergency equipment that must be taken into consideration during the circle check. Although procedures are similar, inspection methods for buses and motor coaches have certain particular characteristics that must be taken into consideration.

Lastly, remember that keeping the circle check report and the applicable list(s) of defects on board the vehicle is mandatory. These lists can be used as checklists and help you when in doubt.

## SUGGESTED 10-STEP METHOD

The suggested detailed circle check method is one that applies to a combination of vehicles made up of a **semi-trailer with a sliding bogie, equipped with air brakes, hitched to a tractor truck**. Adaptations for buses and motor coaches are given at the end of the suggested method.

Regardless of the type of vehicle inspected, it is recommended that you use a method that follows a coordinated sequence of actions that encourage inspections from top to bottom, left to right and front to back.

Note that it is mandatory to inspect the elements listed in bold during the circle check. The numbers in parentheses refer to the table of components (see previous pages). You will have to consult the table to obtain more information on the procedure to follow and the defects to detect.

#### Sequence

1. Approaching the vehicle and preliminary cab check
2. Front of the tractor truck
3. Left side of the tractor truck (driver's side)
4. Centre left side of the semi-trailer (driver's side)
5. Rear left side of the semi-trailer (driver's side)
6. Rear of the semi-trailer
7. Rear right side of the semi-trailer (passenger's side)
8. Centre right side of the semi-trailer (passenger's side)
9. Right side of the tractor truck (passenger's side)
10. Inside the cab (driver's compartment)

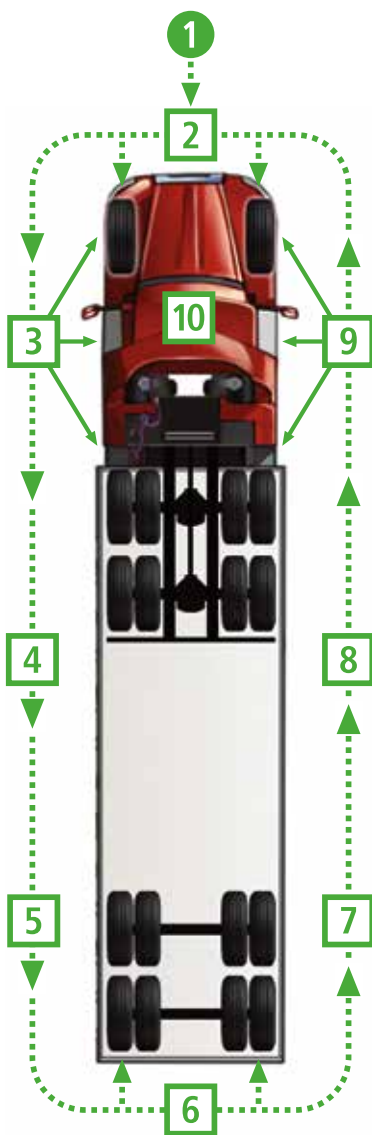

## 1 - Approaching the vehicle and preliminary cab check

Approach the combination of vehicles and observe its general condition to detect indications of defects, such as:

- ▶ a **sagging vehicle**: may indicate a broken spring or an air leak from an air spring
- ▶ **nonparallel wheels**: may indicate a missing or broken part in the spring suspension
- ▶ a **displaced axle**: may indicate an abnormal displacement of one or more axles or wheels
- ▶ **traces of fluid on the ground**: may indicate a fuel or oil leak due to a damaged reservoir or wheel

Enter the cab on the driver's side and close the door.

Make sure that the parking brake is engaged (on both the tractor truck and trailer).

Turn on the low beams, parking and tail lights and right turn signal light (passenger side) and check:

- ▶ the opening and closing of the **driver's door** (10.1)

Get out of the truck and check:

- ▶ the presence of **emergency equipment** (7.1, 7.3 if a fire extinguisher is present in that location)

## 2 - Front of the tractor truck

As you work your way to the front of the vehicle, unlatch the hood on the driver's side. Then, go to the front and face the tractor truck. Check:

- ▶ the **low beams, parking lights and right turn signal light** (8.A, 8.B, 8.1)
- ▶ the **rearview mirrors installed on the hood** (11.3)
- ▶ the **fixed components of the body** (2.3)

Unlatch the hood on the passenger's side, and go back to the front to open the hood.

## 3 - Left side of the tractor truck (driver's side)

### Front, driver's side of the tractor (under the hood)

Go towards the front wheel on the driver's side of the vehicle, and look under the hood to check:

- ▶ the **power steering fluid level** (5.2)
- ▶ the condition of the **power steering pump belt**, if applicable (5.3)
- ▶ the visible parts of the **side rails** (2.A, 2.B, 2.1)
- ▶ the visible parts of the **suspension** (section 14)

**Note:** If the vehicle is equipped with hydraulic brakes, you must also check the fluid level in the master cylinder reservoir (18.1).

## Driver's side of the tractor

Still facing the front wheel, continue your examination of the outside of the vehicle. Move toward the rear of the tractor truck and check:

- ▶ the **tire** and the **valve** (section 9)
- ▶ the **wheel and its fasteners** (12.B, 12.C)
- ▶ for **leaks in the wheel bearings** and their **lubricant level** (12.A, 12.1, 12.2)
- ▶ the **rearview mirror** (11.3)
- ▶ the **body** (2.2, 2.3)
- ▶ the **suspension** (section 14)
- ▶ the **side rail** and the **cross member** (if visible) (2.A, 2.B, 2.1)
- ▶ the **exhaust system** (16.A, 16.1)
- ▶ the **fuel tank** (leaks and anchorages) (15.A, 15.C)
- ▶ the **gas or diesel tank filler cap** (15.C)

## At the rear of the tractor

Move towards the rear of the tractor truck:

- ▶ the **coupling mechanism** (the fifth wheel, for the purposes of this example) (1.B, 1.C, 1.D, 1.E, 1.F, 1.1, 1.2)
- ▶ the upper **coupling plate** and **kingpin**<sup>10</sup> (visible parts) (1.A, 1.F)
- ▶ the truck and semi-trailer's **side rails** and **cross members** (2.A, 2.B, 2.1)
- ▶ the **suspension** (section 14)
- ▶ the **tires** and **valves** (section 9)
- ▶ the **wheels** and their **fasteners** (12.B, 12.C)
- ▶ for **leaks in the wheel bearings** and their **lubricant level** (12.A, 12.1)
- ▶ the **exhaust system** (if applicable) (16.A, 16.1)
- ▶ the **body** (2.2, 2.3)

<sup>10</sup> The appropriate components should be inspected in other types of coupling mechanisms.



## Between the truck and the semi-trailer (beneath the semi-trailer)

### Check:

- ▶ the **fifth wheel jaws** (as needed, use a flashlight for better visibility) (1.E, 1.F)
- ▶ the **upper coupling plate** and **kingpin**<sup>11</sup> (visible parts) (1.A, 1.F)
- ▶ the truck's **tail lights** (8.B, 8.1)
- ▶ the truck's right **turn signal light (passenger side)** (8.B, 8.1)
- ▶ the **body** (2.2, 2.3)

While you are there, check the parts of the suspension, side rails, cross members and parts of the exhaust system or tires that were more difficult to see from the side. Furthermore, in this position when looking towards the rear, you will have a view of the semi-trailer's cross members.

## 4 - Centre left side of the semi-trailer<sup>12</sup> (driver's side)

Go toward the rear of the semi-trailer and check its general condition from top to bottom.

Check beneath the semi-trailer and inspect the parts of the chassis frame and suspension as well as the wheels and sidewalls of the tires on the opposite side; you may be able to detect indications of defects. Also carefully check:

- ▶ the **body** (2.2, 2.3)
- ▶ the semi-trailer's **side rails** and **cross members** (2.A, 2.B, 2.1)
- ▶ the **spare wheel support and anchorages** (12.2)  
(if the semi-trailer is equipped with one)

<sup>11</sup> The appropriate components should be inspected in other types of coupling mechanisms.

<sup>12</sup> In certain documents, this section is called the "lateral centre of the semi-trailer."

## 5 - Rear left side of the semi-trailer (driver's side)

### Facing the semi-trailer's rear wheels, check:

- ▶ the **side rail** and the **locking pins of the sliding bogie** (if applicable, depending on the type of semi-trailer) (2.A, 2.B, 2.C, 2.1, 2.2)
- ▶ the semi-trailer's **side rails** and **cross members** (2.A, 2.B, 2.1)
- ▶ the **suspension** (section 14)
- ▶ the **tires** and **valves** (section 9)
- ▶ the **wheels** and their **fasteners** (12.B, 12.C)
- ▶ for **leaks in the wheel bearings** and their **lubricant level** (12.A, 12.1)

### Go to the rear of the semi-trailer.

## 6 - Rear of the semi-trailer

### Facing the rear of the semi-trailer, check:

- ▶ the **body** (2.2, 2.3)
- ▶ the semi-trailer's **tail lights** (8.B, 8.1)
- ▶ the semi-trailer's right **turn signal light** (passenger side) (8.B, 8.1)
- ▶ the semi-trailer's **licence plate light** (8.1)
- ▶ the semi-trailer's **side rails** and **cross members** (2.A, 2.B, 2.1)
- ▶ the **suspension** (section 14)

**Note:** If some parts were hard to see or access during Step 5, take advantage of your position at the rear of the semi-trailer to check them.

## 7 - Rear right side of the semi-trailer (passenger's side)

Facing the wheels on the passenger's side of the semi-trailer, check:

- ▶ the **side rail** and the **locking pins of the sliding bogie** (2.A, 2.B, 2.C, 2.1)
- ▶ the semi-trailer's **side rails** and **cross members** (2.A, 2.B, 2.1)
- ▶ the **suspension** (section 14)
- ▶ the **tires** and **valves** (section 9)
- ▶ the **wheels** and their **fasteners** (12.B, 12.C)
- ▶ for **leaks in the wheel bearings** and their **lubricant level** (12.A, 12.1)

## 8 - Centre right side of the semi-trailer (passenger's side)

As you move toward the the front of the semi-trailer, check its **general condition**. Look beneath the semi-trailer, like you did on the driver's side in Step 4, and carefully check:

- ▶ the **body** (2.3)
- ▶ the semi-trailer's **side rails** and **cross members** (2.A, 2.B, 2.1)
- ▶ the **spare wheel support and anchorages** (12.2)  
(if the semi-trailer is equipped with one)

## 9 - Right side of the tractor truck (passenger's side)

### At the rear, on the passenger's side of the truck

#### Check:

- ▶ the truck's **parking lights** (8.B, 8.1)
- ▶ the truck's right **turn signal light** (8.B, 8.1)
- ▶ the **body** (2.2, 2.3)
- ▶ the **coupling mechanism** (fifth wheel) (1.B, 1.C, 1.D, 1.E, 1.F, 1.1)
- ▶ the **upper coupling plate** and the **kingpin** (visible parts, if applicable) (1.A, 1.F)
- ▶ the truck and semi-trailer's **side rails** and **cross members** (2.A, 2.B, 2.1)
- ▶ the truck's **suspension** (section 14)
- ▶ the **tires** and **valves** (section 9);
- ▶ the **wheels** and their **fasteners** (12.B, 12.C)
- ▶ for **leaks in the wheel bearings** and their **lubricant level** (12.A, 12.1)

### Between the truck and the semi-trailer

#### Check:

- ▶ the **body** (2.2, 2.3)
- ▶ the **exhaust system** (if applicable) (16.A, 16.1)

You should also take a look at the parts of the suspension, side rails, cross members and parts of the exhaust system or tires that were harder to see from the side.

## Passenger's side of the tractor

Go towards the front on the right side of the tractor and check:

- ▶ the **body** (2.2, 2.3)
- ▶ the **fuel tank** (leaks and anchorages) (15.A, 15.C)
- ▶ the **gas or diesel tank filler cap** (15.B)
- ▶ the **exhaust system** (if applicable) (16.A, 16.1)
- ▶ the **passenger side door** (10.A)
- ▶ the **rearview mirror** (11.2, 11.3)
- ▶ the **side rail and cross members** beneath the cab (2.A, 2.B, 2.1)
- ▶ the **wheel** and its **fasteners** (12.B, 12.C), the **tire** and the **valve** (section 9)
- ▶ for **leaks in the wheel bearings** and their **lubricant level** (12.A, 12.1)

## Front of the tractor truck on the passenger's side (under the hood)

Go towards the front wheel on the passenger's side of the vehicle and check, under the hood:

- ▶ the visible components of the **side rails** (2.A, 2.B, 2.1)
- ▶ the visible parts of the **suspension** (section 14)

Go to the front, close the hood and latch it first on the passenger's side, then on the driver's side.

Go back inside the cab to turn on the left turn signal, and climb back down (in a safe manner, by using three points of support) and check:

- ▶ the **turn signal light** on the front of the tractor on the driver's side, at the rear of the tractor and at the rear of the semi-trailer.

Go back inside the tractor to finish your inspection.

## 10 - Inside the cab (driver's compartment)

Adjust the driver's seat to the desired position and check:

- ▶ the **driver's seat** (13.1)
- ▶ the **seat belt** on the driver's seat (13.A)

Turn the key in the ignition to the "ON" position and check:

- ▶ the **steering wheel** (5.A, 5.1)
- ▶ the **steering column** (5.A, 5.1)
- ▶ the **horn** (4.2)
- ▶ the **rearview mirrors** (11.2, 11.3)
- ▶ the **windshield** (11.1)
- ▶ the **windshield wipers** (6.A, 6.1)
- ▶ the **washer system** (6.2)
- ▶ the **blowers and vents** for the windshield (3.1)
- ▶ the **side windows** located on each side of the cab (depending on vehicle) (11.1, 11.4)
- ▶ the presence of **emergency equipment** in the vehicle (if it is stowed in a location where it could not be inspected at the beginning of the circle check) (section 7)
- ▶ the **braking system** (section 17, 18 or 19, depending on the system with which the vehicle is equipped)

Check the braking system according to the specific instructions that apply to each type of system. Also see sections 17, 18 and 19 in the inspection table for more information.

# INSPECTING A PNEUMATIC BRAKE SYSTEM (AIR BRAKE SYSTEM)

Make sure the vehicle is stable, start the engine, release the parking brake and check:

► **the low air pressure indicator(s)** (19.A, 19.1)

If the low air pressure indicators are not already on:

- ▷ pump the brake pedal a few times to lower the air pressure until the indicator light, buzzer turns on or visual indicator (wigwag) drops.

**Note:** If the low air pressure indicators are on when the vehicle is started, the inspection can be done without further lowering the pressure. The driver must ensure that the air pressure indicated on the pressure gauge is equal or greater than 380 kPa (55 psi) when the indicators turn off.

**Then check:**

► **compressor performance** (19.B)

To do so, while the engine is idling and the air compressor is working:

- ▷ push the brake pedal all the way down and keep it down;
- ▷ watch the pressure gauge;
- ▷ make sure that the compressor can reach and maintain an air pressure of at least 620 kPa (90 psi).

- ▶ the **pressure regulator** (compressor switches off) (19.3)

While the air compressor is still working:

- ▷ let the engine idle and make sure that the compressor switches off when it reaches an air pressure between 805 kPa (117 psi) and 945 kPa (137 psi).

**Note:** At this time, you can keep the engine turning at a greater speed, about 1,000 rpm, to make the air pressure rise a bit more quickly.

### Make sure that air pressure is at maximum.

#### Turn off the engine and check:

- ▶ the **brake system** for leaks (19.C, 19.4)
  - ▷ press down on the brake pedal;
  - ▷ keep the pedal down and check for air leaks (visible on the pressure gauge or audible).

#### Start the engine again and check:

- ▶ the **pressure regulator** (compressor switches on) (19.3)
  - ▷ keep an eye on the air pressure gauge as you slowly decrease the air pressure until the compressor switches back on;
  - ▷ make sure the compressor switches back on before reaching 550 kPa (80 psi).

#### Then perform the following checks:

- ▶ the **semi-trailer's parking brake** (apply and release) (19.5)
  - ▷ apply the semi-trailer's parking brake;
  - ▷ press down on the accelerator (without revving to maximum RPM) to make sure it is working properly;
  - ▷ try to gently move the vehicle forward by shifting into forward gear or, if the vehicle is equipped with a manual transmission, by using the right gear that you can use to drive forward;
  - ▷ make sure the parking brake maintains the vehicle stationary;



- ▶ the **tractor's parking brake** (apply and release) (19.5)
  - ▷ apply the tractor's parking brake;
  - ▷ release the semi-trailer's parking brake;
  - ▷ try again to gently move the vehicle forward;
  - ▷ make sure the parking brake maintains the vehicle stationary.
- ▶ the **clutch mechanism** (4.1)  
the **power steering** (5.B)  
the **service brakes** (19.D)
  - ▷ release the tractor's parking brake;
  - ▷ completely release the clutch pedal in the case of a manual transmission or put the vehicle in forward gear for an automatic transmission;
  - ▷ drive slightly forward in order to be able to turn the steering wheel from one side to the other to make sure that all wheels turn freely and that the power steering is working properly;
  - ▷ press down on the clutch pedal (if applicable) and the service brakes to stop the vehicle.

This helps you check that the service brakes and the clutch mechanism are working properly in the case of a vehicle with a manual transmission.
- ▶ the **accelerator** (4.A, 4.1)
  - ▷ put the gear shift lever back into neutral;
  - ▷ apply the parking brake;
  - ▷ press on the accelerator without going up to the highest rpm, in order to make sure it is working properly.
- ▶ the engine's **exhaust system** (leaks may infiltrate the cab if there are holes in the floorboard) (16.A 16.1)
  - ▷ pay attention to odours that may indicate a fumes leaking from the exhaust system.

- ▶ the **brake lights** of the combination of vehicles (if possible) (8.B, 8.1)
  - ▷ when the location allows you to do so safely or if there is another person to assist you, check the brake lights of the vehicles of the combination for which you are performing a circle check.

**Fill out the circle check report and remember to sign it and carry out the appropriate follow-up if defects have been detected.**

This method can help drivers detect mechanical defects listed in the *Regulation respecting safety standards for road vehicles*. However, no specific method is mandatory. You can develop your own method, but make sure that it allows you to carry out all the required inspections effectively.

## INSPECTING A HYDRAULIC BRAKE SYSTEM

Components of a hydraulic brake system differ from those of an air brake system and require as much attention, because a malfunction could be dangerous.

**Point 18 of the circle check concerning this brake system requires that you check:**

- ▶ the **fluid level in the master cylinder reservoir** (18.A, 18.1)
- ▶ the **working order of the service brake warning light** (18.3)  
the **hydraulic brake booster or vacuum brake booster** (18.C)  
the **air-tightness of the brake system** (18.B, 18.2)

1. As the ignition key is still in the "ON" position;
2. make sure the parking brake is released (this step is necessary only if the service brake pressure warning light is also the warning light for the parking brake);
3. note whether the service brake warning light is on;

**The following sequence of steps in the circle check depends on whether the power brake system is hydraulic or vacuum-assisted.**

**Hydraulic power brakes (electric pump):**

4. apply moderate pressure to the brake pedal and listen to the noise produced by the power brake electric pump;
5. maintain pressure on the brake pedal (stronger than normal braking pressure) for at least 10 seconds;
6. note the brake pedal movement;
7. start the engine;
8. note whether the service brake pressure warning light goes out.

**Vacuum-assisted power brakes:**

4. start the engine;
5. note whether the service brake pressure warning light goes out;
6. let the engine run for a few seconds;
7. turn off the engine and pump the brake pedal several times;
8. apply moderate pressure to the brake pedal and start the engine again while maintaining pressure on the pedal;
9. note the brake pedal movement;
10. maintain pressure on the brake pedal (stronger than normal braking pressure) for at least 10 seconds;
11. note whether the brake pedal maintains its position;
12. start the engine;
13. note whether the service brake pressure warning light goes out.

- ▶ **the effectiveness of the parking brake (18.5)**
- the parking brake warning light (18.4)**
- the effectiveness of the service brake (18.D)**
  - ▷ apply the parking brake;
  - ▷ make sure the parking brake warning light turns on;
  - ▷ try to gently move the vehicle forward by shifting into forward gear or, if the vehicle is equipped with manual transmission, by using the right gear that can be used to drive forward;
  - ▷ make sure the parking brake keeps the vehicle stationary;
  - ▷ release the parking brake and check whether the warning light turns off;
  - ▷ make the vehicle move forward slowly while ensuring that all the wheels are turning freely;
  - ▷ press on the brake pedal to make sure the vehicle stops quickly.

# PARTICULARITIES FOR INSPECTING OTHER TYPES OF VEHICLES

The suggested method for conducting a circle check of a combination of vehicles made up of more than one trailer hitched to a tractor truck is similar to the one presented above. You simply repeat the same inspection applied to the first trailer when you inspect the second one.

More targeted adaptations are necessary for a circle check of straight-body trucks, buses and motor coaches.

## **Straight-body trucks (or straight-body trucks hauling a trailer)**

The circle check of a straight-body truck is similar to the one presented above. Specific adaptations must be made according to the braking system and whether a trailer is hitched to the truck. Here are the various points to pay attention to:

### **Straight-body truck only:**

- ▶ **the coupling system** (1.C, 1.F, 1.1, 1.2)
- ▶ **parking brake (only one to check)** (18.5, 19.5)

### **Straight-body truck hitched to a trailer:**

- ▶ **the coupling system, which is different and located completely at the rear of the straight-body truck** (1.C, 1.F, 1.1, 1.2)

## Buses and motor coaches

The circle check of buses and motor coaches requires particular checks in addition to those that apply to a vehicle reserved for carrying goods, mainly to ensure the safety of passengers. For example, you must also check:

- ▶ **central aisle lighting**
- ▶ **the solidity of the stanchions and the luggage racks and compartments**
- ▶ **the condition of protective material**
- ▶ **accessibility of emergency exits**

The additional inspections, which are mainly listed in section 20 of the components table (see previous pages) may vary according to the layout of the bus based on the type of transportation it provides.

You can review examples of methods adapted to these types of vehicles in the *Circle Check Guide*, available on the SAAQ's website at [saaq.gouv.qc.ca](http://saaq.gouv.qc.ca).

## City buses

In the case of city buses, after completing the usual inspections during your initial approach, some prefer to start the check with the engine compartment, which is usually located at the rear. You can then perform the circle check starting at the front or the rear of the vehicle and continue in the same direction as suggested for the tractor and semi-trailer.

Additional elements to inspect include:

- ▶ **the emergency exit and emergency door warning device** (10.B, 10.C)
- ▶ **part of the emergency material** (in certain cases) (7.1, 7.2)
- ▶ **stanchions, horizontal bars, grab handles, shock-absorbing material, etc.** (20.1, 20.2)
- ▶ **floors and steps** (20.3)
- ▶ **interior lighting** (20.4)
- ▶ **auxiliary or luggage compartments inside the vehicle** (20.5)
- ▶ **seats and benches** (20.6)

## School buses

You may use the circle check method suggested for a straight-body truck and add the additional points specified for city buses, in addition to the following components:

- ▶ the **power steering belt**, often present in these buses (depending on the vehicle's equipment) (5.3)
- ▶ the **windows on both sides of** and directly behind the driver's compartment (11.4)
- ▶ the retractable **stop sign** and its **flashing and alternately flashing lights** (20.7)
- ▶ the **flashing red lights** (20.8)
- ▶ the **alternately flashing yellow lights** (20.8)
- ▶ the **hydraulic brake system**, often present in these types of buses (depending on the vehicle's equipment) (section 18)

## Motor coaches

The circle check of a motor coach is, as for other vehicles, a sight and sound check of the accessible parts of the vehicle and follows the same steps as that of a city bus. However, the configuration of the vehicle sometimes makes the suspension system inaccessible. Furthermore, the chassis frame and body components, generally of a monocoque type, including parts and accessories, are specific to this type of vehicle.

---

To better understand the elements of this chapter and for an optimal learning experience, consult the *Circle Check Guide* and other publications on the SAAQ's website at [saaq.gouv.qc.ca](http://saaq.gouv.qc.ca).

---

# INSPECTIONS WHILE ON THE ROAD

The safety of a vehicle does not depend only on regular maintenance and a thorough circle check. For various reasons, the condition of a vehicle component may deteriorate at any time. You must be attentive to any sign indicating an eventual breakdown or degradation of the quality of securement on your vehicle. Do not hesitate to stop in an appropriate and safe location to carry out inspections if you note an unusual noise or reaction from your vehicle or if a warning light switches on, for example.

Furthermore, you should conduct a new inspection 80 kilometres after you set out for a trip, since all your vehicle's systems have generally been used. After that, an inspection should be performed every 160 kilometres or every two hours. These inspections will help you ensure that all critical systems and components such as tires, brakes, lighting, the coupling mechanism and cargo securement are in good condition and working properly. To avoid stopping too often, perform these checks when you stop for rest and choose services areas for greater safety.



# INSPECTIONS DURING YOUR TRIP

You must perform certain mandatory inspections during your trip. For example, you must stop in areas designated by the road sign shown on the right to test your brakes. You should also perform another inspection of your vehicle's braking system, as performed during the circle check. This check requires only a few minutes and can be carried out in the cab.



During your trip, you should also check the temperature of the wheels to make sure the brake adjustment is adequate and that there is no risk of losing a wheel. Check to make sure there are no traces of lubricant near the wheel hubs. Check whether intense heat, smoke or a burnt smell is coming from one of the wheels. Traces of lubricant near a wheel hub could mean that the hub ring seal is damaged or that a wheel bearing is about to slip out of the cup. You must make sure that there is no risk before setting out again.

If you notice that one wheel produces more heat than the others, the wheel bearing may be faulty or the brake misadjusted. Wait for the wheel to cool down before making a more thorough check to determine the cause, and make sure that you can continue safely.

If one of the wheels has recently been changed, check to make sure it is tight enough after travelling between 80 and 160 km. Wheels should preferably be tightened by a mechanic in accordance with the manufacturer's standards.

# ROADSIDE INSPECTIONS

Heavy vehicle drivers may be stopped by peace officers as part of roadside inspection operations. The purpose of these inspections is to ensure road safety, particularly by removing vehicles that present major defects from the road. They also allow peace officers to check the defects noted on a vehicle and ensure that drivers comply with regulations.

A peace officer may check:

- ▶ the presence of the circle check report and the relevant lists of defects on board the vehicle;
- ▶ the accuracy of the information entered in the circle check report;
- ▶ compliance with regulatory requirements, for example in the case of a vehicle in operation despite a major defect noted during the circle check;
- ▶ the condition of the vehicle.

# INSPECTIONS AT THE END OF A TRIP

Although it is not mandatory, inspecting a vehicle at the end of a trip is recommended. This allows you to record the defects or anomalies you have noted, providing important information on the repairs that should be made before the vehicle is taken back on the road. This practice will benefit your business and save time and money, in addition to ensuring better vehicle safety and the safety of all road users.

# SELF-EVALUATION EXERCISES



## Theoretical Exercises

### True or false

1. Indicate whether the following statements are true or false.

	True	False
1. The circle check must absolutely be performed by the vehicle's driver.	<input type="checkbox"/>	<input type="checkbox"/>
2. While checking a motor coach's braking system, you note an air pressure drop of 35kPa (5 psi) in one minute. This air leak constitutes a minor defect.	<input type="checkbox"/>	<input type="checkbox"/>
3. If the wear of 2 adjacent tire treads on the front tire of a tractor is level with the wear indicator, you cannot operate the vehicle.	<input type="checkbox"/>	<input type="checkbox"/>
4. A driver who detects a minor mechanical defect during a trip is not required to enter it in the circle check report.	<input type="checkbox"/>	<input type="checkbox"/>
5. The driver who performs the circle check does not need to check the power steering fluid level, since this is the mechanic's job.	<input type="checkbox"/>	<input type="checkbox"/>

Answers at the end of the guide.



# APPENDICES

The background features a white upper section and a teal lower section. A large, light blue, wavy graphic element curves from the top right towards the bottom left, creating a sense of movement and depth. The teal section at the bottom is a solid, vibrant color.

# DRIVER'S LICENCE CLASSES

Driver's licence classes that authorize the operation of a heavy vehicle are:

## Class 1

A Class 1 licence authorizes its holder to drive a combination of vehicles, i.e.:



- ▶ a double-axle road tractor with a net weight of 4,500 kg or more hauling one or more trailers or semi-trailers;
- ▶ a triple-axle road tractor hauling one or more trailers or semi-trailers;
- ▶ a truck covered by Class 3 hauling a trailer or semi-trailer with a net weight of 4,500 kg or more used only to carry equipment, tools or furnishings as part of its permanent equipment;
- ▶ a truck covered by Class 3 hauling any trailer or semi-trailer other than those described above, with a net weight of 2,000 kg or more.

**Note:** A road tractor is a motor vehicle that does not have cargo space and that is permanently equipped with a fifth wheel.

Holders of a Class 1 licence may drive all other categories of vehicles, except for motorcycles.

## Class 2

A Class 2 licence authorizes its holder to drive a bus designed to carry more than 24 passengers at a time, i.e.:



A Class 2 authorizes its holder to drive a bus hitched to a trailer, provided the trailer weighs less than 2,000 kg.

Holders of a Class 2 licence may drive all other categories of vehicles, except for combinations of vehicles (Class 1) and motorcycles.

## Class 3

A Class 3 licence authorizes its holder to drive straight-body trucks, i.e.:



- ▶ a double-axle truck with a net weight of 4,500 kg or more, or any truck with three or more axles;
- ▶ a road vehicle is covered by this class when it is hitched to a trailer or semi-trailer:
  - ▷ with a net weight of less than 2,000 kg;
  - ▷ with a net weight of at least 2,000 kg but less than 4,500 kg used only to carry equipment, tools or furnishings as part of its permanent equipment.

Class 3 also authorizes its holder to drive all other categories of vehicles, except motor vehicles covered by Class 1 (combinations of heavy vehicles), Class 2 (buses) and Class 6 (motorcycles).

**Endorsements may be added to Class 1, 2 and 3 driver's licences:**

▶ **F endorsement**

Certifies that the holder of a Class 1, 2 or 3 licence may drive a heavy vehicle equipped with air brakes.

▶ **M endorsement**

Certifies that the holder of a Class 1, 2 or 3 licence may drive a heavy vehicle equipped with a manual transmission.

▶ **T endorsement**



Certifies that the holder of a Class 1 licence may drive a road train, i.e. a double road train with a total length of more than 25 m, requiring a special road train operating permit.



# LISTS OF DEFECTS

## List 1 – Heavy Vehicles

This list applies to heavy vehicles other than a bus, minibus or motor coach. Any trailer towed by a bus, minibus or motor coach must be inspected in accordance with list 2.

 MINOR DEFECTS	 MAJOR DEFECTS
<b>1. Coupling devices</b>	
1.1 Fastener component(s) of the coupling device missing, broken or loose	1.A Coupling plate or kingpin bent to an extent that it makes coupling difficult, cracked or not securely fixed
<b>The defects provided for in points 1.B to 1.F apply when the vehicles are coupled.</b>	
1.2 Safety fasteners and coupling components missing, damaged or insecurely mounted	1.B Movement between the fifth wheel and the frame
	1.C More than 20% of the fasteners of the coupling mechanism damaged or missing
	1.D 25% or more of the locking pins are missing or not working
	1.E Coupling mechanism not properly closed or locked
	1.F Coupling mechanism component missing, insecurely fixed, not properly adjusted or so damaged that it might rupture or fall off

**MINOR DEFECTS**
**MAJOR DEFECTS**
**2. Frame and cargo body**

2.1 Side rails cracked or cross members cracked or broken

2.A Side rails might break

2.2 Fixed components of the body missing or insecurely mounted

2.B Side rails or cross members sagged in a way that makes a mobile part and the body touch

2.C More than 25% of the locking pins of the sliding bogie missing or not engaged

**3. Heater/Defroster**

3.1 Windshield blower not operating

**4. Driver controls**

4.1 Accelerator or clutch not operating properly

4.A Engine fails to return to idle when accelerator is released

4.2 Horn not operating properly

**5. Steering**

5.1 Misplacement of the steering column in relation to the normal position or adjustable steering wheel not remaining in set position

5.A Misplacement of the steering column or wheel in relation to the normal position showing a risk of separation

5.2 Fluid level of power steering not the one prescribed by the manufacturer

5.B Power steering inoperative

5.3 Pump belt cut



## MINOR DEFECTS

## MAJOR DEFECTS

**6. Windshield wiper/washer**

6.1 Wiper on passenger's side missing or inadequate

6.A Wiper on driver's side missing or inadequate

6.2 Windshield washer system ineffective

**7. Emergency material**

7.1 First-aid kit required by law insecurely fixed and not readily accessible

7.2 Chemical extinguisher required by law insecurely fixed, inadequate and not readily accessible

**8. Headlights and lights**

8.1 Low beam, parking light, turn-indicator light, brake light or license plate light that does not turn on

8.A Failure of all low-beams

8.B At the rear of a single-unit vehicle or the last vehicle of a combination of vehicles:

- ▶ Failure of all turn-indicator lamps
- ▶ Failure of all brake lights
- ▶ Failure of all parking lights



## MINOR DEFECTS

## MAJOR DEFECTS

## 9. Tires

9.1 Wear indicator for a tire touches the roadway or depth of a groove is equal to or less than the wear indicator

9.A For a tire mounted on the steering axle of a motor vehicle having a GVWR of 4,500 kg or more, the depth of 2 adjacent grooves is equal to or less than the wear indicator

9.2 A tire in the same wheel assembly having foreign material embedded in the tread or sidewall that could cause a puncture

9.B Single tire or the dual tires of the same wheel assembly having foreign material embedded in the tread or sidewall that could cause a puncture

9.3 A tire in the same wheel assembly so damaged that the cord or steel belt is exposed

9.C Single tire or the dual tires of the same wheel assembly so damaged that the cord or steel belt is exposed

9.4 Distorted tire, tread or sidewall separated from the carcass of the tire

9.D Tire in contact with a fixed part of the vehicle, a flat tire or a tire losing air or a bulge

9.5 Valve usée, endommagée, écorchée ou coupée

## 10. Doors and other openings

10.1 Driver's door opens with difficulty or fails to open

10.A Passenger compartment door fails to close securely



## MINOR DEFECTS



## MAJOR DEFECTS

### 11. Glass and mirrors

11.1 Windshield or side window on each side of the driver's compartment fails to provide the required view to the driver as a result of being damaged

11.2 Outside rearview mirrors required by the Code missing, damaged or may not be adjusted and remain in set position

11.3 Outside rearview mirror insecure or shows a sharp edge

### 12. Wheels, hubs and fasteners

12.1 Lubricant under the minimum level or lubricant leakage of wheel bearing other than oozing

12.A Wheel bearing lubricant missing or not visible through a sight glass

12.2 Support or mounting holding the spare wheel not securely fixed to hold it

12.B Wheel fastener is missing, cracked, broken or insecure

12.C Wheel damaged or shows signs of repair with welds

### 13. Seat

13.1 Driver's seat inadequate or not staying in set position

13.A Driver's seat belt missing, modified or inadequate



## MINOR DEFECTS



## MAJOR DEFECTS

## 14. Suspension

14.1 Leaf spring other than a main spring leaf or broken coil spring	14.A Main spring leaf, rubber pad or 25% or more of the leaf springs in the assembly are broken or missing
14.2 Air leak in suspension, ball so damaged that the cord is exposed or repaired	14.B Air leak in the system not compensated by compressor or ball missing or deflated
	14.C Component for mounting the axle missing, insecure, cracked or broken
	14.D Composite spring leaf cracked over 75% of its length or has cracks
	14.E Leaf spring or coil spring moved and in contact with moving parts
	14.F Coil spring so broken that the vehicle is completely sagged or torsion bar cracked
	14.G Broken axle or component for positioning the axle or wheel missing, insecure, cracked, broken or damaged so as to affect the parallelism or cause an axle or wheel to move out of its position



## MINOR DEFECTS



## MAJOR DEFECTS

15. Fuel system	
	15.A Tank poorly fixed and could break loose
	15.B Cap missing
	15.C Fuel leak other than oozing
16. Exhaust system	
16.1 Leak of exhaust gas elsewhere than where intended by the manufacturer	16.A Leak that causes exhaust gas to enter the passenger compartment where the floor is perforated
17. Electric brake system	
17.1 Cable or electric connection not securely attached to the fasteners or connection	17.A Important reduction in the braking capacity of the service brake
18. Hydraulic brake system	
18.1 Fluid level in the reservoir of the master cylinder below minimum level required	18.A Fluid level in the reservoir of the master cylinder lower than one quarter of the maximum level specified by the manufacturer
18.2 Brake pedal reaches the floor	18.B Brake pedal reaches the floor within less than 10 seconds or pedal has to be depressed several times before getting pressure
18.3 Warning light on while the engine is running or not on where the ignition key is in the "on" or "start" position	18.C Brake boost or power assist is inoperative
18.4 Warning light not on when the parking brake is applied or not turned off when released	18.D Important reduction in the braking capacity of the service brake
18.5 Parking brake not operating properly	



## MINOR DEFECTS

## MAJOR DEFECTS

## 19. Pneumatic brake system

19.1 Low pressure warning buzzer not operating properly	19.A No low pressure visual or warning light or buzzer is operating properly
19.2 Low pressure visual and warning lights not operating properly	19.B Air compressor not operating properly
19.3 Pressure regulator not operating properly	19.C Air leak whose rate within one minute exceeds 40 kPa (6lb/in <sup>2</sup> ) for a single-unit vehicle, 48 kPa (7lb/in <sup>2</sup> ) for a two-unit vehicle and 62 kPa (9lb/in <sup>2</sup> ) for a three-unit vehicle
19.4 Audible air leak or whose rate within one minute exceeds 20kPa (3lb/in <sup>2</sup> ) for a single-unit vehicle, 28kPa (4lb/in <sup>2</sup> ) for a two-unit vehicle and 35 kPa (5lb/in <sup>2</sup> ) for a three-unit vehicle	19.D Important reduction in the braking capacity of the service brake
19.5 Parking or emergency brake not operating properly	

## Specific inspections required by the operator



## List 2 – Buses

This list applies to buses (other than motor coaches), minibuses and any trailer towed by a bus, minibus or motor coach.



### MINOR DEFECTS



### MAJOR DEFECTS

#### 1. Coupling devices

The defects provided for in points 1.C and 1.F apply when vehicles are coupled.

1.1 Fastener component(s) of the coupling device missing, broken or loose

1.C More than 20% of the fasteners of the coupling mechanism damaged or missing

1.2 Safety fasteners and coupling components missing, damaged or insecurely mounted

1.F Coupling mechanism component missing, insecurely fixed, not properly adjusted or so damaged that it might rupture or fall off

#### 2. Frame and cargo body

2.1 Side rails cracked or cross members cracked or broken

2.A Side rails might break

2.2 Fixed components of the body missing or insecurely mounted

2.B Side rails or cross members sagged in a way that makes a mobile part and the body touch

2.3 Outside door of a luggage or auxiliary compartment inadequate or not securely mounted on the road vehicle

#### 3. Heater/Defroster

3.1 Windshield blower not operating

**MINOR DEFECTS**
**MAJOR DEFECTS**
**4. Driver controls**

4.1 Accelerator or clutch not operating properly

4.A Engine fails to return to idle when accelerator is released

4.2 Horn not operating properly

**5. Steering**

5.1 Misplacement of the steering column in relation to the normal position or adjustable steering wheel not remaining in set position

5.A Misplacement of the steering column or wheel in relation to the normal position showing a risk of separation

5.2 Fluid level of power steering not the one prescribed by the manufacturer

5.B Power steering inoperative

5.3 Pump belt cut

**6. Windshield wiper/washer**

6.1 Wiper on passenger's side missing or inadequate

6.A Wiper on driver's side missing or inadequate

6.2 Windshield washer system ineffective

**7. Emergency material**

7.1 First-aid kit required by law insecurely fixed and not readily accessible

7.2 Chemical extinguisher required by law insecurely fixed, inadequate and not readily accessible



## MINOR DEFECTS



## MAJOR DEFECTS

## 8. Headlights and lights

8.1 Low beam, parking light, turn-indicator light, brake light or license plate light that does not turn on	8.A Failure of all low-beams
	8.B At the rear of a single-unit vehicle or the last vehicle of a combination of vehicles: <ul style="list-style-type: none"> <li>▶ Failure of all turn-indicator lamps</li> <li>▶ Failure of all brake lights</li> <li>▶ Failure of all parking lights</li> </ul>

## 9. Tires

9.1 Wear indicator for a tire touches the roadway or depth of a groove is equal to or less than the wear indicator	9.A For a tire mounted on the steering axle of a motor vehicle having a GVWR of 4,500 kg or more, the depth of 2 adjacent grooves is equal to or less than the wear indicator
9.2 A tire in the same wheel assembly having foreign material embedded in the tread or sidewall that could cause a puncture	9.B Single tire or the dual tires of the same wheel assembly having foreign material embedded in the tread or sidewall that could cause a puncture
9.3 A tire in the same wheel assembly so damaged that the cord or steel belt is exposed	9.C Single tire or the dual tires of the same wheel assembly so damaged that the cord or steel belt is exposed
9.4 Distorted tire, tread or sidewall separated from the carcass of the tire	9.D Tire in contact with a fixed part of the vehicle, a flat tire or a tire losing air or a bulge
9.5 Valve worn down, damaged, scraped or gashed	



## MINOR DEFECTS

## MAJOR DEFECTS

## 10. Doors and other openings

10.1 Driver's door opens with difficulty or fails to open

10.A Passenger compartment door fails to close securely

10.B Emergency exit blocked

10.C Emergency door inadequate or its warning light or buzzer not in good working order

## 11. Glass and mirrors

11.1 Windshield or side window on each side of the driver's compartment fails to provide the required view to the driver as a result of being damaged

11.2 Outside rearview mirrors required by the Code missing, damaged or may not be adjusted and remain in set position

11.3 Outside rearview mirror insecure or shows a sharp edge

11.4 Side window of a school bus on each side of the driver's compartment and immediately behind the driver's compartment fails to provide the required view to the driver as a result of being damaged



## MINOR DEFECTS

## MAJOR DEFECTS

**12. Wheels, hubs and fasteners**

12.1 Lubricant under the minimum level or lubricant leakage of wheel bearing other than oozing

12.A Wheel bearing lubricant missing or not visible through a sight glass

12.2 Support or mounting holding the spare wheel not securely fixed to hold it

12.B Wheel fastener is missing, cracked, broken or insecure

12.C Wheel damaged or shows signs of repair with welds

**13. Seat**

13.1 Driver's seat inadequate or not staying in set position

13.A Driver's seatbelt missing modified or inadequate

**14. Suspension**

14.1 Leaf spring other than a main spring leaf or broken coil spring

14.A Main spring leaf, rubber pad or 25% or more of the leaf springs in the assembly are broken or missing

14.2 Air leak in suspension, ball so damaged that the cord is exposed or repaired

14.B Air leak in the system not compensated by compressor or ball missing or deflated

14.C Component for mounting the axle missing, insecure, cracked or broken

14.D Composite spring leaf cracked over 75% of its length or has cracks

14.E Leaf spring or coil spring moved and in contact with moving parts

14.F Coil spring so cracked or broken that the vehicle is completely sagged or torsion bar cracked

14.G Broken axle or component for positioning the axle or wheel missing, insecure, cracked, broken or damaged so as to affect the parallelism or cause an axle or wheel to move out of its position



## MINOR DEFECTS

## MAJOR DEFECTS

## 15. Fuel system

15.A Tank poorly fixed and could break loose

15.B Cap missing

15.C Fuel leak other than oozing

## 16. Exhaust system

16.1 Leak of exhaust gas elsewhere than where intended by the manufacturer

16.A Leak that causes exhaust gas to enter the passenger compartment where the floor is perforated

## 17. Electric brake system

17.1 Cable or electric connection not securely attached to the fasteners or connection

17.A Important reduction in the braking capacity of the service brake

## 18. Hydraulic brake system

18.1 Fluid level in the reservoir of the master cylinder below minimum level required

18.A Fluid level in the reservoir of the master cylinder lower than one quarter of the maximum level specified by the manufacturer

18.2 Brake pedal reaches the floor

18.B Brake pedal reaches the floor within less than 10 seconds or pedal has to be depressed several times before getting pressure

18.3 Warning light on while the engine is running or not on where the ignition key is in the "on" or "start" position

18.C Brake boost or power assist is inoperative

18.4 Warning light not on when the parking brake is applied or not turned off when released

18.D Important reduction in the braking capacity of the service brake

18.5 Parking brake not operating properly



## MINOR DEFECTS



## MAJOR DEFECTS

19. Pneumatic brake system	
19.1 Low pressure warning buzzer not operating properly	19.A No low pressure visual or warning light or buzzer is operating properly
19.2 Low pressure visual and warning lights not operating properly	19.B Air compressor not operating properly
19.3 Pressure regulator not operating properly	19.C Air leak whose rate within one minute exceeds 40 kPa (6lb/in <sup>2</sup> ) for a single-unit vehicle, 48kPa (7lb/in <sup>2</sup> ) for a two-unit vehicle and 62 kPa (9lb/in <sup>2</sup> ) for a three-unit vehicle
19.4 Audible air leak or whose rate within one minute exceeds 20kPa (3lb/in <sup>2</sup> ) for a single-unit vehicle, 28kPa (4lb/in <sup>2</sup> ) for a two-unit vehicle and 35 kPa (5lb/in <sup>2</sup> ) for a three-unit vehicle	19.D Important reduction in the braking capacity of the service brake
19.5 Parking or emergency brake not operating properly	



## MINOR DEFECTS

## MAJOR DEFECTS

## 20. Passenger transport

- |   |  |
|---|--|
| 20.1 Stanchion, horizontal bar, grab handle and guard panel insecure                            |  |
| 20.2 Shock-absorbing material provided by the manufacturer on stanchions missing or inadequate  |  |
| 20.3 Floor or steps of passenger compartment damaged  |  |
| 20.4 Lighting of passenger access or aisle inoperative  |  |
| 20.5 Top luggage rack or top luggage compartment insecure or cannot retain luggage              |  |
| 20.6 Passenger's seat or bench seat inadequate  |  |
| 20.7 Stop sign not operating properly or one of the flashing lights does not turn on            |  |
| 20.8 One of the flashing lights or one of the alternately flashing yellow lights do not turn on |  |

### Specific inspections required by the operator



## List 3 – Motor Coaches

This list applies to motor coaches. Any trailer towed by the motor coach must be inspected in accordance with list 2.



### MINOR DEFECTS



### MAJOR DEFECTS

#### 1. Coupling devices

The defects provided for in points 1.C and 1.F apply when vehicles are coupled.

1.1	Fastener component(s) of the coupling device missing, broken or loose	1.C	More than 20% of the fasteners of the coupling mechanism damaged or missing
1.2	Safety fasteners and coupling components missing, damaged or insecurely mounted	1.F	Coupling mechanism component missing, insecurely fixed, not properly adjusted or so damaged that it might rupture or fall off

#### 2. Frame and cargo body

2.2	Fixed components of the body missing or insecurely mounted		
2.3	Outside door of a luggage compartment or of an auxiliary compartment inadequate or insecurely mounted on a road vehicle		

#### 3. Heater/Defroster

3.1	Windshield blower not operating		
-----	---------------------------------	--	--

#### 4. Driver controls

4.1	Accelerator or clutch not operating properly	4.A	Engine fails to return to idle when the accelerator is released
4.2	Horn not operating properly		

**MINOR DEFECTS**
**MAJOR DEFECTS**
**5. Steering**

5.1 Misplacement of the steering column in relation to the normal position or adjustable steering wheel not remaining in set position	5.A Misplacement of the steering column or wheel in relation to the normal position showing a risk of separation
5.2 Fluid level of power steering not the one prescribed by the manufacturer	5.B Power steering inoperative
5.3 Courroie de la pompe présente une coupure	

**6. Windshield wiper/washer**

6.1 Wiper on passenger's side missing or inadequate	6.A Wiper on driver's side missing or inadequate
6.2 Windshield washer system ineffective	

**7. Emergency material**

7.1 First-aid kit required by law insecurely fixed and not readily accessible	
7.2 Chemical extinguisher required by law insecurely fixed, inadequate and not readily accessible	



## MINOR DEFECTS



## MAJOR DEFECTS

## 8. Headlights and lights

8.1 Low beam, parking light, turn-indicator light, brake light or license plate light that does not turn on

8.A Failure of all low-beams

8.B At the rear of a single-unit vehicle or the last vehicle of a combination of vehicles:

- ▶ Failure of all turn-indicator lamps
- ▶ Failure of all brake lights
- ▶ Failure of all parking lights

## 9. Tires

9.1 Wear indicator for a tire touches the roadway or depth of a groove is equal to or less than the wear indicator

9.A For a tire mounted on the steering axle of a motor vehicle having a GVWR of 4,500 kg or more, the depth of 2 adjacent grooves is equal to or less than the wear indicator

9.2 A tire in the same wheel assembly having foreign material embedded in the tread or sidewall that could cause a puncture

9.B Single tire or the dual tires of the same wheel assembly having foreign material embedded in the tread or sidewall that could cause a puncture

9.3 A tire in the same wheel assembly so damaged that the cord or steel belt is exposed

9.C Single tire or the dual tires of the same wheel assembly so damaged that the cord or steel belt is exposed

9.4 Distorted tire, tread or sidewall separated from the carcass of the tire

9.D Tire in contact with a fixed part of the vehicle, a flat tire or a tire losing air or a bulge

9.5 Valve worn down, damaged, scraped or gashed



## MINOR DEFECTS

## MAJOR DEFECTS

**10. Doors and other openings**

10.1 Driver's door opens with difficulty or fails to open

10.A Passenger compartment door fails to close securely

10.B Emergency exit blocked

**11. Glass and mirrors**

11.1 Windshield or side window on each side of the driver's compartment fails to provide the required view to the driver as a result of being damaged

11.2 Outside rearview mirror required by the Code missing, damaged or may not be adjusted and remain in set position

11.3 Outside rearview mirror insecure or shows a sharp edge



## MINOR DEFECTS

## MAJOR DEFECTS

**12. Wheels, hubs and fasteners**

12.1 Lubricant under the minimum level or lubricant leakage of wheel bearing other than oozing

12.A Wheel bearing lubricant missing or not visible through a sight glass

12.2 Support or mounting holding the spare wheel not securely fixed to hold it

12.B Wheel fastener is missing, cracked, broken or insecure

12.C Wheel damaged or shows signs of repair with welds

**13. Seat**

13.1 Driver's seat inadequate or not staying in set position

13.A Driver's seat belt missing, modified or inadequate

**14. Suspension**

14.2 Air leak in suspension, ball so damaged that the cord is exposed or repaired

14.B Air leak in the system not compensated by compressor or ball missing or deflated

14.G Broken axle or component for positioning the axle or wheel missing, insecure, cracked, broken or damaged so as to affect the parallelism or cause an axle or wheel to move out of its position

**15. Fuel system**

15.A Tank poorly fixed and could break loose

15.B Cap missing

15.C Fuel leak other than oozing



## MINOR DEFECTS

## MAJOR DEFECTS

**16. Exhaust system**

16.1 Leak in exhaust system elsewhere than where intended by the manufacturer

16.A Leak that causes exhaust gas to enter the passenger compartment where the floor is perforated

**17. Electric brake system (not subject to inspection)****18. Hydraulic brake system (not subject to inspection)****19. Pneumatic brake system**

19.1 Low pressure warning buzzer not operating properly

19.A No low pressure visual or warning light or buzzer is operating properly

19.2 Low pressure visual and warning lights not operating properly

19.B Air compressor not operating properly

19.3 Pressure regulator not operating properly

19.C Air leak whose rate within one minute exceeds 40 kPa (6lb/in<sup>2</sup>) for a single-unit vehicle, 48 kPa (7lb/in<sup>2</sup>) for a two-unit vehicle and 62 kPa (9lb/in<sup>2</sup>) for a three-unit vehicle

19.4 Audible air leak or whose rate within one minute exceeds 20kPa (3lb/in<sup>2</sup>) for a single-unit vehicle, 28kPa (4lb/in<sup>2</sup>) for a two-unit vehicle and 35 kPa (5lb/in<sup>2</sup>) for a three-unit vehicle

19.D Important reduction in the braking capacity of the service brake

19.5 Parking or emergency brake not operating properly



## MINOR DEFECTS



## MINOR DEFECTS

**20. Passenger transport**

20.1 Stanchion, horizontal bar, grab handle and guard panel insecure

20.2 Shock-absorbing material provided by the manufacturer on stanchions missing or inadequate

20.3 Floor or steps of passenger compartment damaged

20.4 Lighting of passenger access or aisle inoperative

20.5 Top luggage rack or top luggage compartment insecure or cannot retain luggage

20.6 Passenger's seat or bench seat inadequate

**Specific inspections required by the operator**

# LAWS AND REGULATIONS

## Laws

- ▶ Act respecting owners, operators and drivers of heavy vehicles
- ▶ *Highway Safety Code*
- ▶ Transport Act

## Regulations

- ▶ Bus Transport Regulation
- ▶ Cargo Securement Standards Regulation
- ▶ Regulation respecting access to driving a road vehicle in connection with the health of drivers
- ▶ Regulation respecting environmental standards for heavy vehicles
- ▶ Regulation respecting licences
- ▶ Regulation respecting road vehicles used for the transportation of school children
- ▶ Regulation respecting safety standards for road vehicles
- ▶ Regulation respecting special permits
- ▶ Regulation respecting the Act respecting owners, operators and drivers of heavy vehicles
- ▶ Regulation respecting the hours of driving and rest of heavy vehicle drivers
- ▶ Regulation respecting the training of drivers of buses and minibuses used for the transportation of schoolchildren and of vehicles used for the transportation of schoolchildren
- ▶ Special Road Train Operating Permits Regulation
- ▶ Transportation of Dangerous Substances Regulation
- ▶ Vehicle Load and Size Limits Regulation



# DOCUMENTS AND PUBLICATIONS

## Société de l'assurance automobile du Québec

- ▶ Angles morts des véhicules lourds – Soyez vigilant !  
(in French only)
- ▶ Circle Check Guide
- ▶ Conduct Review Policy and Excellence Program  
for Heavy Vehicle Drivers
- ▶ Conduct Review Policy for Heavy Vehicle Owners and Operators
- ▶ Driver Fatigue – Fatigue Management Guide
- ▶ Driving and Off-Duty Time for Heavy Vehicle Drivers
- ▶ Driving and Off-Duty Time for Heavy Vehicle Drivers –  
Fact Sheet
- ▶ Fatigue au volant (conducteurs de véhicules lourds)  
(in French only)
- ▶ Information Bulletin for Heavy Vehicle Drivers,  
Owners and Operators
- ▶ Mechanical Inspection Guide
- ▶ Medical Assessment to Drive in the United States
- ▶ Obligations of Heavy Vehicle Users
- ▶ Programme nord-américain de gestion de la fatigue  
(folder in French Only)
- ▶ Prospective Heavy Vehicle Driver
- ▶ Straight Talk on Fatigue and Alertness
- ▶ Wheel Loss – A Risk No One Can Run!
- ▶ Wheel Loss Due to Faulty Bearings

## Ministère des Transports du Québec

- ▶ Aide-mémoire sur la signalisation routière des véhicules lourds (in French only)
- ▶ Atlas des transports (réseau de camionnage) (in French only)
- ▶ Bulletins Info-Camionnage (in French only)
- ▶ Cargo Securement Guide
- ▶ Carte papier du réseau de camionnage (in French only)
- ▶ Guide des routes interdites aux camions (in French only)
- ▶ Hindrances Related to Load and Size
- ▶ La circulation des véhicules lourds sur le réseau routier municipal (in French only)
- ▶ Répertoire des hauteurs libres (in French only)
- ▶ Répertoire des limitations de poids (in French only)
- ▶ Road Vehicle Load and Size Limits Guide
- ▶ Surcharge de la masse totale en charge (in French only)

## Commission des transports du Québec

- ▶ A Commission decision is a serious matter!  
You must comply with it
- ▶ Gérez la sécurité! (in French only)
- ▶ Heavy Vehicle Drivers – Drive Safely...  
The Commission des transports du Québec can summon you to appear
- ▶ N’y allez pas par 4 chemins  
(Single-window service for carriers – in French only)
- ▶ What to do when you are summoned before the Commission des transports du Québec

# PRESSURE CONVERSION TABLE

psi	kPa	bar	psi	kPa	bar	psi	kPa	bar	psi	kPa	bar
1.00	6.90	0.07	41.00	282.90	2.83	81.00	558.90	5.58	121.00	834.90	8.34
2.00	13.80	0.14	42.00	289.80	2.90	82.00	565.80	5.65	122.00	841.80	8.41
3.00	20.70	0.21	43.00	296.70	2.96	83.00	572.70	5.72	123.00	848.70	8.48
4.00	27.60	0.28	44.00	303.60	3.03	84.00	579.60	5.79	124.00	855.60	8.55
5.00	34.50	0.34	45.00	310.50	3.10	85.00	586.50	5.86	125.00	862.50	8.62
6.00	41.40	0.41	46.00	317.40	3.17	86.00	593.40	5.93	126.00	869.40	8.69
7.00	48.30	0.48	47.00	324.30	3.24	87.00	600.30	6.00	127.00	876.30	8.76
8.00	55.20	0.55	48.00	331.20	3.31	88.00	607.20	6.07	128.00	883.20	8.83
9.00	62.10	0.62	49.00	338.10	3.38	89.00	614.10	6.14	129.00	890.10	8.89
10.00	69.00	0.69	50.00	345.00	3.45	90.00	621.00	6.21	130.00	897.00	8.96
11.00	75.90	0.76	51.00	351.90	3.52	91.00	627.90	6.27	131.00	903.90	9.03
12.00	82.80	0.83	52.00	358.80	3.59	92.00	634.80	6.34	132.00	910.80	9.10
13.00	89.70	0.90	53.00	365.70	3.65	93.00	641.70	6.41	133.00	917.70	9.17
14.00	96.60	0.97	54.00	372.60	3.72	94.00	648.60	6.48	134.00	924.60	9.24
15.00	103.50	1.03	55.00	379.50	3.79	95.00	655.50	6.55	135.00	931.50	9.31
16.00	110.40	1.10	56.00	386.40	3.86	96.00	662.40	6.62	136.00	938.40	9.38
17.00	117.30	1.17	57.00	393.30	3.93	97.00	669.30	6.69	137.00	945.30	9.45
18.00	124.20	1.24	58.00	400.20	4.00	98.00	676.20	6.76	138.00	952.20	9.51
19.00	131.10	1.31	59.00	407.10	4.07	99.00	683.10	6.83	139.00	959.10	9.58
20.00	138.00	1.38	60.00	414.00	4.14	100.00	690.00	6.89	140.00	966.00	9.65
21.00	144.90	1.45	61.00	420.90	4.21	101.00	696.90	6.96	141.00	972.90	9.72
22.00	151.80	1.52	62.00	427.80	4.28	102.00	703.80	7.03	142.00	979.80	9.79
23.00	158.70	1.59	63.00	434.70	4.34	103.00	710.70	7.10	143.00	986.70	9.86
24.00	165.60	1.65	64.00	441.60	4.41	104.00	717.60	7.17	144.00	993.60	9.93
25.00	172.50	1.72	65.00	448.50	4.48	105.00	724.50	7.24	145.00	1000.50	10.00
26.00	179.40	1.79	66.00	455.40	4.55	106.00	731.40	7.31	146.00	1007.40	10.07
27.00	186.30	1.86	67.00	462.30	4.62	107.00	738.30	7.38	147.00	1014.30	10.14
28.00	193.20	1.93	68.00	469.20	4.69	108.00	745.20	7.45	148.00	1021.20	10.20
29.00	200.10	2.00	69.00	476.10	4.76	109.00	752.10	7.52	149.00	1028.10	10.27
30.00	207.00	2.07	70.00	483.00	4.83	110.00	759.00	7.58	150.00	1035.00	10.34
31.00	213.90	2.14	71.00	489.90	4.90	111.00	765.90	7.65	151.00	1041.90	10.41
32.00	220.80	2.21	72.00	496.80	4.96	112.00	772.80	7.72	152.00	1048.80	10.48
33.00	227.70	2.28	73.00	503.70	5.03	113.00	779.70	7.79	153.00	1055.70	10.55
34.00	234.60	2.34	74.00	510.60	5.10	114.00	786.60	7.86	154.00	1062.60	10.62
35.00	241.50	2.41	75.00	517.50	5.17	115.00	793.50	7.93	155.00	1069.50	10.69
36.00	248.40	2.48	76.00	524.40	5.24	116.00	800.40	8.00	156.00	1076.40	10.76
37.00	255.30	2.55	77.00	531.30	5.31	117.00	807.30	8.07	157.00	1083.30	10.82
38.00	262.20	2.62	78.00	538.20	5.38	118.00	814.20	8.14	158.00	1090.20	10.89
39.00	269.10	2.69	79.00	545.10	5.45	119.00	821.10	8.20	159.00	1097.10	10.96
40.00	276.00	2.76	80.00	552.00	5.52	120.00	828.00	8.27	160.00	1104.00	11.03

# MEASUREMENT CONVERSION TABLE (LENGTH)

Imperial (inch)			Metric (mm)			
Fraction		Thousandth of an inch	0 to 1 inch	1 to 2 inches	2 to 3 inches	3 to 4 inches
1/32	1/64	0.015	0.397	25.40	50.80	76.20
		0.031	0.794	25.80	51.20	76.60
	3/64	0.046	1.191	26.19	51.59	76.99
1/16		0.062	1.588	26.59	51.99	77.39
	5/64	0.078	1.984	26.99	52.39	77.79
	3/32	0.093	2.381	27.38	52.78	78.18
1/8	7/64	0.109	2.778	27.78	53.18	78.58
		0.125	3.175	28.18	53.58	78.98
	9/64	0.140	3.572	28.58	53.98	79.38
5/32		0.156	3.969	28.97	54.37	79.77
	11/64	0.171	4.366	29.37	54.77	80.17
		0.187	4.763	29.77	55.17	80.57
3/16	13/64	0.203	5.159	30.16	55.56	80.96
	7/32	0.218	5.556	30.56	55.96	81.36
	15/64	0.234	5.953	30.96	56.36	81.76
1/4		0.250	6.350	31.35	56.75	82.15
	17/64	0.265	6.747	31.75	57.15	82.55
	9/32	0.281	7.144	32.15	57.55	82.95
5/16	19/64	0.296	7.541	32.54	57.94	83.34
		0.312	7.938	32.94	58.34	83.74
	21/64	0.328	8.334	33.34	58.74	84.14
11/32		0.343	8.731	33.73	59.13	84.53
	23/64	0.359	9.128	34.13	59.53	84.93
		0.375	9.525	34.53	59.93	85.33
3/8	25/64	0.390	9.922	34.93	60.33	85.73
	13/32	0.406	10.319	35.32	60.72	86.12
	27/64	0.421	10.716	35.72	61.12	86.52
7/16		0.437	11.113	36.12	61.52	86.92
	29/64	0.453	11.509	36.51	61.91	87.31
	15/32	0.468	11.906	36.91	62.31	87.71
1/2	31/64	0.484	12.303	37.31	62.71	88.11
		0.500	12.700	37.70	63.10	88.50
	33/64	0.515	13.097	38.10	63.50	88.90
9/16	17/32	0.531	13.494	38.50	63.90	89.30
	35/64	0.546	13.891	38.89	64.29	89.69
		0.562	14.288	39.29	64.69	90.09
5/8	37/64	0.578	14.684	39.69	65.09	90.49
	19/32	0.593	15.081	40.08	65.48	90.88
	39/64	0.609	15.478	40.48	65.88	91.28
11/8		0.625	15.875	40.88	66.28	91.68
	41/64	0.640	16.272	41.28	66.68	92.08
	21/32	0.656	16.669	41.67	67.07	92.47
13/16	43/64	0.671	17.066	42.07	67.47	92.87
		0.687	17.463	42.47	67.87	93.27
	45/64	0.703	17.859	42.86	68.26	93.66
3/4	23/32	0.718	18.256	43.26	68.66	94.06
	47/64	0.734	18.653	43.66	69.09	94.46
		0.750	19.050	44.05	69.45	94.85
13/32	49/64	0.765	19.447	44.45	69.85	95.25
	25/32	0.781	19.844	44.85	70.25	95.65
	51/64	0.796	20.241	45.24	70.64	96.04
7/8		0.812	20.638	45.64	71.04	96.44
	53/64	0.828	21.034	46.04	71.44	96.84
	27/32	0.843	21.431	46.43	71.83	97.23
15/16	55/64	0.859	21.828	46.83	72.23	97.63
		0.875	22.225	47.23	72.63	98.03
	57/64	0.890	22.622	47.63	73.03	98.43
29/32		0.906	23.019	48.02	73.42	98.82
	59/64	0.921	23.416	48.42	73.82	99.22
		0.937	23.813	48.82	74.22	99.62
31/32	61/64	0.953	24.209	49.21	74.61	100.01
		0.968	24.606	49.61	75.01	100.41
	63/64	0.984	25.003	50.01	75.41	100.81
				50.40	75.80	101.20

# ANSWERS TO THE QUESTIONS AT THE END OF EACH CHAPTER



## Answer key

### Chapter 1

1. True
2. True
3. False
4. True
5. True

### Chapter 2

#### Multiple choice questions

1. c
2. a
3. a
4. c
5. c
6. a
7. a
8. a
9. a
10. c

#### True or false

1. True
2. False
3. False
4. True

### Chapter 3

1. True
2. False
3. True
4. False
5. False

### Chapter 4

1. False
2. False
3. False
4. False
5. True

### Chapter 5

1. False
2. True
3. False
4. True
5. False

## Chapter 6

1. False
2. False
3. True
4. False
5. True

## Chapter 7

1. False
2. True
3. False
4. True
5. True

## Chapter 8

1. False
2. False
3. True
4. False
5. True

## Chapter 9

1. True
2. True
3. False
4. True
5. False

## Chapter 10

1. False
2. True
3. True
4. True
5. False

## Chapter 11

1. True
2. True
3. True

## Chapter 12

1. False
2. True
3. True
4. False
5. False



Printed in April 2022  
by Marquis imprimeur inc.  
in Montmagny (Québec)